

The Northern Sea Route

The shortest sea route linking East Asia and Europe

The Ship and Ocean Foundation

About the Bibliography

This book is the English-language version of "Hokkyokukai Koro", an instructional report originally written in Japanese about research on the Northern Sea Route. In the Japanese version, an abridged bibliography was provided to avoid burdening the Japanese reader. This English version is faithfully translated from the Japanese and therefore the provided bibliography is not in accordance with prevailing English-language convention.

The Northern Sea Route

-The shortest sea route linking East Asia and Europe -

Supervised by **Hiromitsu Kitagawa**

Published by **Yoshio Kon**

Printed by **Senkosha**

Copyright © 2001 SHIP & OCEAN FOUNDATION

All Right Reserved. ISBN 4-88404-027-9

SHIP & OCEAN FOUNDATION

15-16, Toranomom 1-chome, Minato-ku, Tokyo 105-0001, JAPAN

TEL:81-3-3502-1828 FAX:81-3-3502-2033 URL:<http://www.sof.or.jp>

Preface



Yohei Sasakawa

Chairman of the Steering Committee of Sponsors of
International Northern Sea Route Program

What images does the phrase “Arctic Ocean” bring to mind? An ocean covered with vast sheets of ice. A vast, white wilderness, whose night sky is often illuminated by the unearthly kaleidoscope of the aurora. Both these images suggest a harsh but ethereal natural beauty, where human activity is but a distant rumor.

Viewed from directly above the North Pole, the Arctic Ocean is a closed sea, hemmed in by the great North American and Eurasian continents and the barren island of Greenland. Russia, the United States and Canada face each other around this circle of ice-infested water. For this reason, the Arctic Ocean held a position of crucial strategic importance during the cold war—so much so that the Soviet Union kept its northern coast completely off limits to other countries.

The Arctic Ocean was opened to the world in 1987, when the then Secretary General of the Soviet Communist Party, Mikhail Gorbachev, declared the Arctic Ocean an international entity. With this dramatic shift in attitude, the Arctic Ocean was transformed from a barrier between Europe and Asia into the shortest sea lane linking the two great regions.

It is now eight years ago that Terje Johhannessen, Norway’s Ambassador to Japan, stated that “Norway would like to conduct joint research with Russia on the possibility of year-round operation of the Northern Sea Route (NSR), and we sincerely hope that Japan will be an equal partner in this program.” Upon listening to the Ambassador’s arguments, I agreed to collaborate in all aspects of the projects, stating that

For centuries, most of the myths about sailing conditions along the Northern Sea Route have been grounded on incomplete understanding of the historical route. The wealth of data that Russia has amassed on the natural and social environment in the Arctic Ocean holds out an extraordinary opportunity. By accessing this valuable data and constructing a basis for further survey and research efforts and seconding the necessary personnel, Japan and Russia can seize the chance to promote the cultural exchange between them to develop a timely and historic international project.

The three principal cooperative partners, the Fridtjof Nansen Institute (FNI) in Norway, the Central Marine Research and Design Institute (CNIIMF) in Russia and the Ship & Ocean Foundation (SOF) in Japan, formed an international joint project called the International Northern Sea Route Programme (INSROP). The mission of this program was to shatter the myths about the NSR and replace them with scientific knowledge over a six-year period beginning in 1993.

The fruits of this six-year labor are prodigious. Some 390 front-line researchers from 14 countries took part, creating a corpus of 167 reports on the natural, social, economic and legal environment of the NSR that was widely hailed as the 20th century’s last great legacy of comprehensive research results. In addition to historical and statistical data, project participants gathered the latest information on the Arctic region at frequent intervals,

Preface

constructing the world's foremost geographical information system on the Arctic Ocean. This valuable resource will be used not only for upcoming academic research but as a storehouse of relevant information to guide decision-making on a wide range of social and economic issues. Japan believes that the collaboration will also establish a pattern of private-sector diplomacy that strongly supports diplomacy among the participating governments, deepening the relationship of trust between Japan and Russia across a broad front.

Thanks to the results of this research program, it is now clear that it is technologically feasible to keep a northern sea route (NSR) open not only during the summer months, but even in the depth of winter, with the support of icebreakers. Moreover, this research has highlighted the issues that must be addressed in the future to bring the NSR to fruition as a shipping route. At the International NSR Users' Forum held last year in Norway, Russia declared its intention to take concerted steps to apply this new knowledge.

If the NSR becomes a commercial reality, East Asia and Europe will be connected by a sea route that is roughly half as long as the southern route through the Suez Canal. The economic benefits would be huge, and the existence of two routes instead of the sole route currently available will represent a tremendous boost to the security of international shipping. In addition, the Arctic region is rich in natural resources that would contribute handsomely to the world economy if brought to market.

This book is a compilation of data focusing on the results of the International Northern Sea Route Programme (INSROP) and on those of the collaborative domestic research project (JANSROP) supported by the Nippon Foundation. Particular attention is focused on the results of an experimental voyage through the NSR aboard the *Kandalaksha*, a Russian icebreaking cargo vessel. I am confident that this volume will prove useful for students of the NSR as well as for individuals and organizations involved in shipping and trade and for government decision-makers.

Finally, I wish to express my most sincere gratitude to a long list of talented individuals. I am grateful for the assistance of the many people in Japan and from numerous countries involved in INSROP. The members of the Japan Northern Sea Route Project Research Committee, and particularly Yuzuru Fujita, Professor Emeritus of University of Tokyo and Chair of the Committee, offered their unstinting advice and cooperation, and I thank them sincerely. This book would also not have been possible without such worthy contributors as Professor Hiromitsu Kitagawa of Hokkaido University. To all of the people mentioned above and numerous others, I extend my most sincere thanks.

March 1, 2000

CONTENTS

1. Introduction.....	1
2. Background to the NSR.....	5
2.1 Historical Background.....	5
2.1.1 From ancient times to the voyage of Nordenskjold.....	5
2.1.2 From Nordenskjold to the Russian Revolution.....	10
2.1.3 The Russian Revolution and its aftermath.....	11
2.2 Political and Social Background.....	13
2.3 Economic and Shipping Background.....	14
2.4 Technological background.....	16
3. Natural Conditions in the NSR.....	19
3.1 Natural Conditions in the Arctic.....	19
3.1.1 Physiography of the Arctic Ocean.....	19
3.1.2 The Midnight Sun and Temperatures in the Arctic Ocean.....	20
3.1.3 The Aurora Borealis and Magnetic Storms.....	21
3.1.4 The Ozone Hole at the North Pole and the Increase in Harmful UV Radiation.....	22
3.1.5 The Arctic Air Mass and Tracks of Polar Cyclones.....	24
3.1.6 Arctic Stratus (Clouds) and Arctic Haze.....	25
3.1.7 Seasonal Changes in Albedo.....	26
3.1.8 Glacial Periods and Ice Sheets in the Northern Hemisphere.....	27
3.1.9 Permafrost.....	28
3.1.10 Subarctic Coniferous Flora.....	29
3.1.11 Mineral Resources.....	30
3.2 Characteristics of the Arctic Ocean.....	31
3.2.1 Rivers Flowing into the Arctic Ocean.....	31
3.2.2 Oceanic Structure and Deep Water Formation in the Arctic Ocean.....	32
3.2.3 Sea Ice.....	33
3.2.4 The Extent of Sea Ice in the Northern Hemisphere.....	34
3.2.5 Ocean Currents and Ice Drifts in the Arctic Ocean.....	35
3.3 Natural Conditions in the NSR.....	36
3.3.1 Geographical Environment.....	36
3.3.2 Low-salinity Water.....	37
3.3.3 Sea Ice.....	38
3.3.4 Precipitation and Snow Cover.....	40
3.3.5 Puddles.....	41
3.3.6 Pressure ridges.....	42
3.3.7 Ocean Currents and Tides.....	43

CONTENTS

3.3.8 Marine Life	43
4. Technological Aspects of NSR Navigation	45
4.1 Ice-transiting Ships	45
4.1.1 Requirements for Icebreaking Ships	45
4.1.2 Icebreaking Ships in Russia	51
4.1.3 Research and Development in Icebreaking Ships	57
4.2 Routes and Aids to Navigation	64
4.2.1 Features of the NSR and Route Selection	64
4.2.2 Aids to Navigation	71
4.3 NSR Rules and Procedures	79
4.3.1 Administration	80
4.3.2 Procedure for requesting permission to navigate the NSR.....	81
4.3.3 Technical requirements for ships	81
4.3.4 Navigational requirements	84
4.3.5 Control of Ship Routes and Selection of Routes.....	84
4.3.6 Evaluation in Terms of International Law.....	85
4.3.7 Conclusion	89
4.4 Evaluation of Economic Viability.....	89
4.4.1 Changes in Shipping Volume.....	90
4.4.2 Present State of Shipping	91
4.4.3 Potential for Transit Traffic on the NSR	92
4.4.4 Cost simulation	93
4.5 Environmental Impact and Preservation	111
4.5.1 Structure of the Arctic Ocean.....	111
4.5.2 Indigenous Peoples and the Ecosystem in the Arctic Ocean.....	112
4.5.3 Activity in the NSR and Environmental Factors	115
4.5.4 Environmental Impact Assessments.....	117
4.5.5 Environmental regulations	121
4.5.6 Conclusion	128
4.6 Geographic Information System.....	128
4.6.1 Introduction	128
4.6.2 System Features and Composition.....	129
4.6.3 Contents of the Database	129
4.6.4 Application Examples	132
5. Experimental Voyage through Northern Sea Route.....	135
5.1 Introduction	135
5.2 Test Planning	135
5.3 Test Results.....	137
5.4 Conclusions	146

6. Issues to be Resolved for NSR Operation.....	147
6.1 Related Technology	147
6.2 Operation System.....	149
6.3 Economic, Social and Political Systems for the NSR.....	149
6.3.1 The Economy	149
6.3.2 Society, Politics and Legislation	152
6.4 Insurance.....	156
6.5 Natural and Biological Environment	156
6.6 Concluding Remarks	158
7. Perspective on the NSR.....	159
8. Postscript.....	163
Reference Materials.....	165
Appendix.....	169

1. Introduction

The quest for a sea passage across the Arctic Ocean, linking Europe to the Far East, began with the Age of Commerce in the 15th century, when great seafaring European powers emerged seeking trade routes to the Orient. Over the ensuing centuries the Arctic passage yielded itself gradually, as the objectives of its pioneers shifted from whaling and sealing to prospecting for precious metals and other natural resources, and later to scientific exploration. As understanding of this vast, forbidding region unfolded, explorers deepened their knowledge of the geographical problems of the Arctic Ocean and its natural conditions.

One of the most vital sea routes between the Far East and Europe is the Southern Sea Route, which threads through the Straits of Malacca and across the Indian Ocean to pass through the Suez Canal. A northern passage, crossing the Bering Sea into the Barents Sea of Russia's far north and hugging Russia's Arctic shore, would constitute a mere 60% of the distance of its southern counterpart. Given the intense competition prevailing in the world shipping market, the potential economic benefits of exploiting this Northern Sea Route (NSR) would be enormous. The irresistible attraction of such a route drives this age-old quest into the present day.

The obstacles, however, are daunting. The natural environment of the Arctic Ocean is too hostile for freighters without resort to sophisticated shipbuilding technology and extensive support systems. Without the remarkable advances in shipbuilding and navigation of recent years, commercial exploitation of this route would be inconceivable. The first task for prospective Arctic seafarers, then, is to gain an accurate picture of the North's forbidding natural environment. Once an accurate assessment is made, the next task is develop technologies to design and construct ships capable of navigating the ice-covered seas and satellite-based systems to provide current information on ice conditions, and to put into effect the technological, political and legal framework needed to support NSR shipping.

For many years, Russia's northern seas were off limits to the outside world. With the advent of perestroika in Russia, however, interest in opening up the polar ocean as an international shipping zone has been rekindled, spurring impressive strides in the development of requisite technologies. Today, for the first time, tangible preparations are under way to link Europe and the Far East with the NSR as a viable shipping lane.

Another powerful draw for Arctic shipping is the region's vast energy resources. In a world where environmental issues are increasingly pressing and hold a persistently high public profile, demand is growing for the development of new sources of energy to satisfy the world's prodigious thirst for energy, driving resource developers into ever more inhospitable corners of the earth, including the polar regions. Also attracting intense interest is Russia's rich trove of energy resources. Already, the development of oil and gas fields is under way in such remote places as the Barents Sea and the Sea of Okhotsk around Sakhalin Island. Moreover, the influence and importance of the Arctic region on global climate, weather and ecosystem of the earth is widely recognized. An urgent priority in this project is the conquest of the various natural conditions that obstruct academic surveying and research, so that valuable and significant data can be collected to contribute to our knowledge of this vast region.

The authors believe that, when these recent polar initiatives are taken into account, the technological, economic and political case for development of the NSR as a shipping route is strong and credible. To support the informed examination of Japan's energy policy for the 21st century and shipping trends, a clear accounting of the conditions required to blaze this new trail in maritime trade is urgently needed.

To that end, in 1993 the Ship & Ocean Foundation (SOF) gained the support of The Nippon Foundation to participate in the launch of INSROP. This project is the brainchild of three national agencies: the SOF in Japan,

1. Introduction

the Fridtjof Nansen Institute (FNI) in Norway and the Central Marine Research and Design Institute (CNIIMF) in Russia.

A couple of organizational structures were required to ensure a clear and consistent focus in INSROP's activities. To coordinate the various opinions of the three national bodies listed above, INSROP established a Steering Committee of Sponsors (SCS). Presiding over this committee is Yohei Sasagawa, chair of The Nippon Foundation. At the same time, INSROP set up a Joint Research Committee to coordinate specific research details and issues and to propose and adjust research plans.

The SOF has established a Japan Committee for the Northern Sea Route Project (JANSROP), headed by chair Yuzuru Fujita, Professor Emeritus of University of Tokyo. Consisting of prominent persons active in the fields of shipbuilding, shipping, meteorology, energy and polar research, this committee is responsible for promoting progress in the INSROP international collaborative project. In parallel with its work on the INSROP project, JANSROP is pressing ahead with survey and research effort on optimum design of NSR cargo vessels. This project enjoyed the benefits of extensive studies on icebreaking oil tankers for transport of energy resources in the Beaufort Sea as a springboard for Japan's ongoing development of polar-sea shipping technologies, while continuing to build on the results of INSROP's navigation technology.

JANSROP has conducted a wide range of valuable projects, including the development of vessels optimized for NSR navigation; analysis of the performance of propellers for ice-transiting vessels and research on the interference between ice and the propellers; research on the interference between the ice pack and ocean waves; analysis of actual ice data; and prediction of ice-floe behaviors. In 1995, to compare these research results with actual in-site data, JANSROP chartered the icebreaking cargo ship M/V Kandalaksha, owned by Murmansk Shipping Co. in Russia, and conducted an experimental voyage via the NSR with Russian crew, together with Japanese, Russian and Canadian researchers. This mission gathered basic data for the establishment of safe and efficient NSR navigation. This sea trial was also able to confirm that a short route between Yokohama and the port of Kirkenes in Norway could be negotiated, providing in-depth experience and understanding of the state of the natural environment in the Arctic Ocean.

A detailed discussion of INSROP is provided in Appendix 1. Here we offer a brief overview.

INSROP consisted of two phases: Phase I, which was executed between 1993 and 1995; and Phase II, which covered the years 1997 and 1998. During the interim phase of 1996, an international evaluating committee was established, consisting of a neutral assembly of learned persons. This committee examined and evaluated the results of Phase I, then consulted with respect to the necessity of Phase II, directions in research and the order of precedence of the various research issues to determine the details of the plan for Phase II.

Phase I research activities were divided into the following four sub-programs of the NSR. Each of the issues examined and mooted by the JRC was entrusted to specialists from the participating countries, who conducted individual survey and research efforts.

- * Sub-program I : Natural conditions and Ice Navigation
- * Sub-program II : Environmental Factors
- * Sub-program III : Trade and Commercial Shipping Aspects
- * Sub-program IV : Political, Legal and Strategic Factors

These individual research issues were submitted to the FNI, which serves as the secretariat of INSROP, within a given time-frame as a discussion paper. Outside specialists were then called upon to evaluate and deliberate on the details of the research. A revised version of the document, containing additions, revisions and comments by these outside specialists, was then published as an INSROP working paper (WP).

In Phase II, the research performed in Phase I was supplemented and most of the results of the research

conducted by INSROP are collated to form a geographical information system about the NSR, called the INSROP Geographic Information System (INSROP GIS). This INSROP GIS was used in conducting simulations of NSR operation, to provide comprehensive evaluation. The NSR operation simulations were carried out by a number of specialists both within and outside the INSROP community, to afford a general idea of how NSR ships should be designed and indicate the economic viability of operations. Simulations were conducted to select routes; assess the state of sea ice in each zone into which the NSR was divided and subdivided; develop a navigational support system; forecast commodities and their movement; and take into account environmental impact and legal and legislative issues. This method enabled detailed study of various operation modes and the potential profitability of operations.

In the end some 167 working papers were produced in Phases I and II (Appendix 7) and an Integration Book (WP-167), a comprehensive compilation of INSROP's research, was published in book form by a Dutch publishing company. These documents are today held at the facilities of the SOF.

In writing this book the authors hope to build a bridge linking Russia with the nations of both Europe and the Far East, and to present a picture of a future economic zone encompassing the Russian Far East and the Far East Asia that may one day compare well with the European Union. Based on the research results of INSROP and JANSROP, this volume outlines the history of the NSR, the natural conditions faced by the project, various operating technologies, and future issues.

1. Introduction

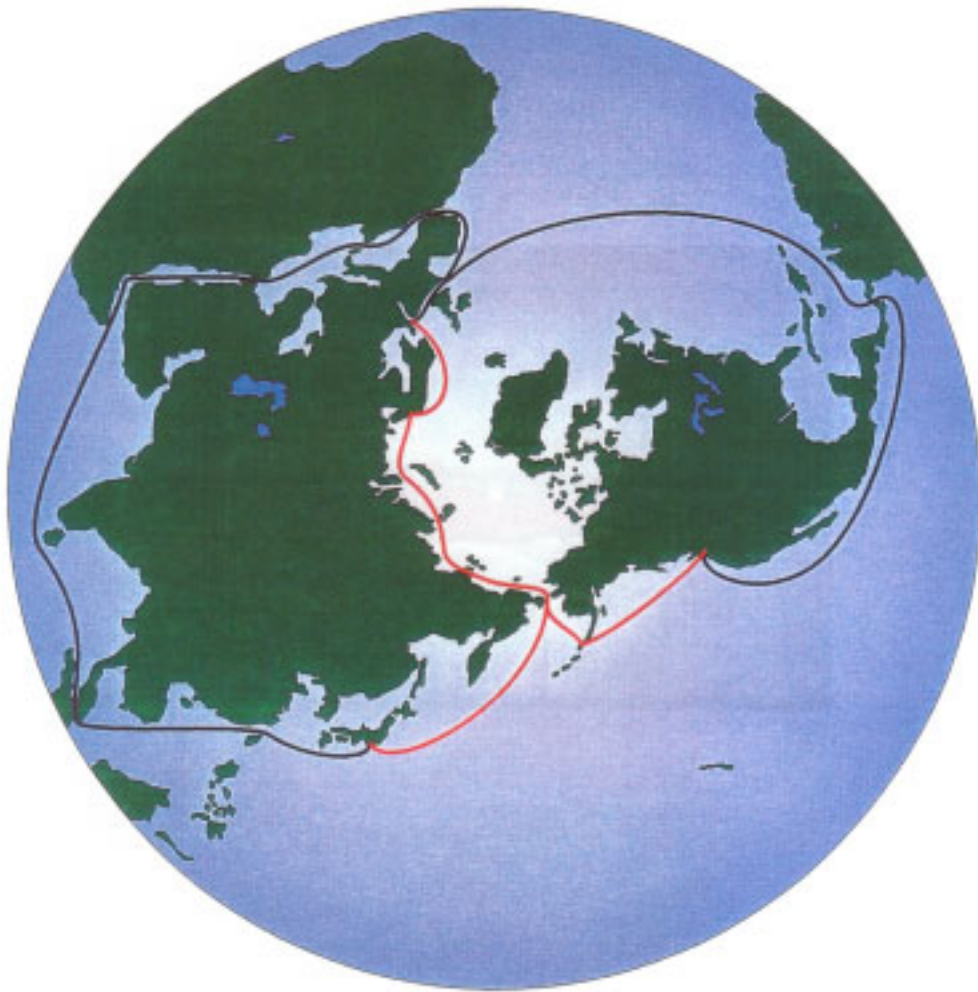

2. Background to the NSR

History reveals that the opening of a single sea route can send shock waves around the world, transforming the economic, social, legal and even political systems of the countries affected. When Vasco da Gama rounded the Cape of Good Hope on the southern tip of Africa in a long and grueling sea voyage, he ushered in several centuries of lucrative trade that produced turbulent social conditions throughout Africa and Asia and profoundly affected the nations of Europe.

Today, when the facts about our small planet are so well publicized, some observers have suggested that the immediate impact on the world economy of the opening of an NSR would not be as powerful as that of the opening of the southern route and construction of the Suez Canal. In the long term, however, as resources are developed in regions adjacent to the route, the possibility is undeniable that the NSR may one day redraw the map of the global economy.

To assess the potential value and impact of the opening of this new commercial shipping route, a wide range of perspectives is needed. We have to look at the relevant history, covering not only the natural conditions in the affected land and sea areas but social aspects as well. Equally important is a clear assessment of progress in the development of nautical technology.

Motives for the opening of new sea routes throughout history

– 8th century	Accidental discovery of new routes in the quest for fishing grounds
9th–10th century	Plundering property and extension of spheres of control: Era of the Vikings
10th–14th century	Exploration for fisheries and furs
15th–18th century	Search for natural resources and new trade routes
19th–20th century	Surveying of water routes, exploration for natural resources, defense and military strategy: The cold war
20th century–	Exploration for energy and opening of commercial shipping routes

2.1 Historical Background

2.1.1 From ancient times to the voyage of Nordenskjöld

It is impossible to have a fruitful discussion of the present state of matters involving natural phenomena or human affairs, or to forecast their development in the future, without an adequate understanding of the historical background. History is the compass by which we navigate the shoals of long-term forecasting to imagine what the ideal state of a system would be like.

The indigenous peoples of North America

The history of the Arctic Circle has its roots in the arrival of the indigenous peoples of the region. These include the Innu, the Athabaskan or Dene nation and the coastal-dwelling hunter communities of the Inuit. Traces of the movement of these peoples can be found throughout the Arctic. Even among people who lived far from Arctic shores, the existence of ice-covered seas in the far north was well known. Passages describing a frozen sea are seen, for example, in classical Greek literature. In fact, it is known that Greek and Roman geographers and astronomers in the 4th and 5th centuries BC deduced from the layout of the known world and the distribution of hot and cold weather therein that a frozen ocean must exist in the north. Over the passage of time, fragmentary evidence from first-hand experience of the northern ice fields trickled southward. Until well into the Christian era, no planned or deliberate efforts were made to find this sea of ice; rather, the ancients

2. Background to the NSR

came about this information haphazardly, from accidental finds of flotsam and the like. Even in this period long before the Renaissance, however, remarkably accurate intelligence about the far north had been accrued, attested in a wide variety of literature and other historical records. Thereafter, interest in the subject declined, to be awakened after the Renaissance in what may be termed a “rediscovery” of the Arctic.

Interest in Western Europe

In the 7th and 8th centuries, European exploration of the Arctic began with the voyages of Irish monks, who handed down intriguing tales of journeys to far-off lands in leather vessels called coracles. Various accounts of expeditions by monks and fishermen to the Arctic Ocean from the 5th to 10th century are recorded, including many fanciful tales of a paradise of abundant fish and terrible oceans of ice. The most reliable reports come from the Irish monks, whose admittedly fragmentary information about the far north was used by the settlers of the Faroe Islands and Iceland.

The Vikings

In the 8th century, the torch of maritime exploration passed from the Irish monks to the Norse Vikings. Farmers in origin but possessed of extraordinary seafaring skills, the Vikings began their navigation career sailing along the coastlines of northern Europe in small boats. Later, as the Vikings honed their shipbuilding acumen, they gradually built bigger ships that extended their activity area, and began invading, plundering and wiping out rival tribes. In their heyday in the 10th century, the Vikings ruled a vast domain that stretched from the Caspian Sea to the Spanish coast.

Terrorizing Europe from their base on the rugged coast that is now Norway, the seafaring Vikings earned a reputation for brutality that was the stuff of legend for centuries afterward. But that harsh temperament enabled the Norsemen to cut a path across some pitiless and capricious seas. The Vikings reached the White Sea coast and settled southern Iceland, where their descendants still live today. In 984 one of the most famous Vikings in history, Erik the Red, led a party to Greenland, where they established a colony. His son, Leif Eriksson, is known to have reached the coast of North America, which he named Vinland; the ruins of one of his settlements can still be seen today in the Canadian province of Newfoundland. The Vikings were the first Europeans to encounter the Inuit and other original inhabitants of the Arctic, and the value of their contribution to the ultimate opening of the NSR is immeasurable. However, we cannot praise their contribution unreservedly. This is because the Vikings left few written records and virtually none of their precious nautical experience survives to the present day. Furthermore, they often exterminated the original inhabitants of these bitterly cold environments.

Whaling exploration

By the 14th century, a new contributor to the quest for the NSR took the stage. From their homes nestled on the broad arc of Biscay Bay, the Basques ventured further and further north in their search for whales, rediscovering the Newfoundland coast and whaling in the fog-bound seas off the Labrador coast. The Basques were soon followed by whalers from the Netherlands, then from England. After demand for whale meat fell, the whalers were able to revive their flagging industry by extracting large quantities of whale oil and baleen from their quarry. This led to intense competition among whalers as the hunters pressed ever northward in the search for new whaling grounds. Although this struggle pushed the whale to the brink of extinction, it also provided a rapid expansion in our knowledge of the Arctic Ocean.

As the foregoing discussion shows, deliberate efforts to navigate and explore the northern seas began with

the search for whales. Eventually the hunt widened to include marine mammals other than whales, as well as reindeer. From humble beginnings as a subsistence way of life, whaling and other Arctic hunting grew in quantity to become the basis for barter, and ultimately of full-fledged trade.

Seafaring skills in the Age of Commerce

Two of the most important tools used by 16th-century seafarers were the compass and the astrolabe. Using log lines, and given the speed of the vessel, they could ascertain the rough longitude of the craft in a technique called dead "reckoning." The astrolabe was employed to determine latitude with remarkable accuracy. With the aid of a table of the sun's declination over the course of a year and a simple tool called a cross-staff, even more accurate measurements could be obtained. This method of determining position by the angle of the sun has a long pedigree; the solar declination tables are said to have been calculated originally by the Arabs. In the mid-13th century King Alphonso X of Castile introduced these tables into Christendom, and to this day they are still known in the West as "Alphonso's tables."

The Portalano Chart

The oldest of the Portalano Chart dates back to the 1300s. Their astounding degree of completeness suggests that these maps were continually redrawn and corrected over successive generations. The "Normal Portalano" is an exquisitely beautiful piece, drawn on vellum with colored ink. The Mediterranean and Black Seas and the coastlines of western Europe and northern Africa are rendered in painstaking detail, while the inland areas are almost completely blank.

Hand-drawn charts

Extending their range of navigation in search of new resources, seafarers had to adapt not only the ships themselves but also the ways in which they lived their lives aboard their vessels in the icy polar seas. Great strides were also seen in the art of navigation, informed by hard experience. During this period the seafarers drew maps by hand, building the foundations of the craft of mapmaking in the Age of Navigation. The antecedents of this impressive art reach as far back as the Portalano Charts of the Middle Ages. These ancient maps displayed a far greater accuracy than the first maps produced on a printing press, which reflected a Ptolemaic world-view and symbolized the power structure prevalent in medieval times. It was the Portalano Charts that influenced and guided the seafarers of the northern seas.

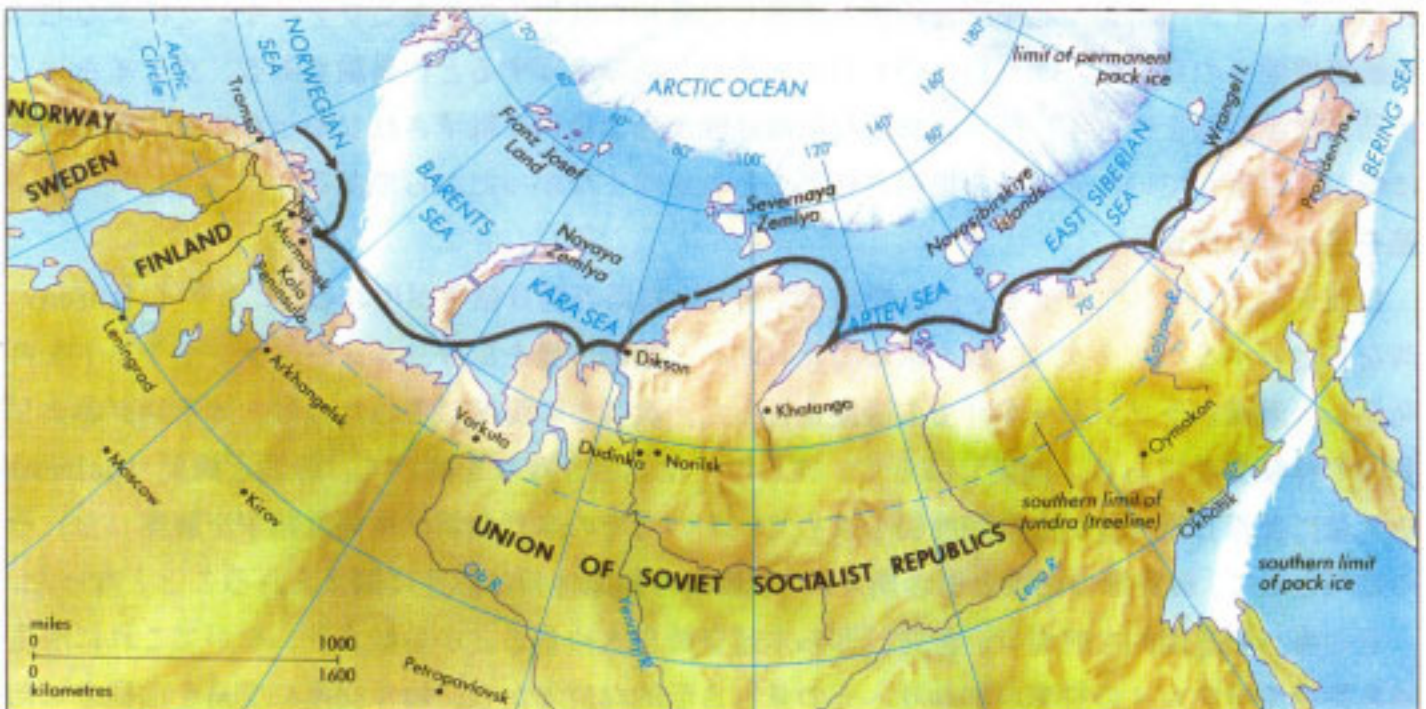

The Northeast Passage (Stonehouse, 1990)



The Northwest Passage (Stonehouse, 1990)

The Age of Commerce

As the endless quest for resources ventured further into the seas to the north of Europe and thence to the east and west, the dreams of adventurers turned ineluctably to the opening of new sea routes. The search for two elusive new routes, termed the Northeast Passage and the Northwest Passage, marked the clear beginning of a new Age of Commerce.

Spurred by the exploits of the whalers, the first explorer to seek a new route to China through the Arctic Ocean was John Cabot. A Venetian captain in the merchant marine who lived in the bustling English port of Bristol, Cabot was commanded by King Henry VII to sail westward in search of new lands to claim for the English crown. In 1496 Cabot duly discovered both Newfoundland and Labrador, setting the cornerstone for the later British dominion over Canada. John Cabot's son, Sebastian Cabot, who is believed to have accompanied the elder Cabot on the Newfoundland voyage, followed in his father's footsteps. A prosperous merchant, Sebastian played a leading role in the early years of England's colonization program. Sebastian obtained the sponsorship of Northumberland county and, with the enthusiastic backing of London's most eminent citizens, advocated the establishment of a joint-stock company of adventurer-traders. The younger Cabot organized an expeditionary force of three ships, which set sail under the command of Lord Willoughby in 1553. Although Lord Willoughby discovered Novaya Zemlya, he was an early casualty of the northern exploration effort, freezing to death along with his entire crew on a foray into Lapland. Sebastian was unbowed by this tragic setback. In 1555 he established a group of London businessmen to found a trading company called the Muscovy Company, with the aim of fostering trade with Russia. Sebastian Cabot entrusted the dream of finding the new sea route to a young captain named Stephen Burrough, who set out in a small pinnace named the *Searchthrift*. Burrough rounded the Kola Peninsula beyond the northern tip of Norway and crossed the Kara Sea south of Novaya Zemlya, becoming the first sailor to successfully navigate the coast of Siberia.

The English had numerous rivals in the scramble for northern trade routes. In 1578 the Dutch launched trading relations with Russia to acquire furs and lumber from Arkhangelsk. The merchants of Amsterdam, seeking further sea passages to the east, enlisted Willem Barents, a seasoned mariner famed for the voyages of the *Terschelling*, to explore the possibility of a route through the extreme northern latitudes, sailing a vessel called the *Mercurius*. In those days it was still believed that sea ice lay only in regions close to the coast, and

that open water would be found around the North Pole. Although Barents explored the west coast of Novaya Zemlya in great detail on his first voyage, in neither his first or second voyage did Barents succeed in his ultimate objective. In his third expedition, which departed from the port of Amsterdam in May 1596, Barents pressed further eastward, discovering Bear Island and Svalbard. Unfortunately for Barents, his vessel was beset in sea ice and unavoidably beached. Afterward, though most of his crew returned to the Netherlands alive, Barents himself never saw his homeland again.

Not long after Barents' adventures in the northeast, the English captain Henry Hudson set off in search of a new passage. Marshaling his experience from the Muscovy Company, in May 1607 Hudson set sail in the 80-ton Hopewell in search of a route to Japan and China across the Arctic Ocean. Pressing northward as far as the 73rd parallel, Hudson explored the east coast of Greenland, then pressed even further north to plot the west coast of Svalbard at 81°N latitude. In his report to his sponsors, Hudson noted that the seas in this region were excellent whaling grounds, and indeed for many years thereafter the far north Atlantic was a paradise for the whaling fleet. His next two expeditions were less successful. On his second voyage in 1608, Hudson was unable to find any trace of the open polar sea he had expected to encounter, and his 1609 outing in search of a Northeast Passage, bankrolled by the Dutch East India Company, was frustrated by unfavorable winds. Hudson resolved to turn his prow westward and seek a Northwest Passage instead. In 1610, once again under English patronage, Hudson undertook an exploratory voyage that yielded the discovery of a vast inland sea that still bears his name—Hudson Bay. The explorer wintered on the shores of Hudson Bay and set sail for England the following spring, only to meet a bitter end when mutinous sailors forced Hudson, his son and a few loyal crewmembers into a small launch. Nothing is known of what became of Hudson and his small party. This terrible episode is today remembered as one of the most grievous tragedies in the long and bloodstained history of the Northwest Passage.

Hudson was followed in his quest for the Northwest Passage by a long list of illustrious adventurers, such as John Davis, Robert Bylot, William Baffin and Thomas Button. As repeated attempts to push east of the Kara Sea failed, explorers gave up hope for the Northeast Passage. From the time of Barents onward, except for a few traders still intent on a coastal route to Russia, a century would pass before anyone would brave the Northeast Passage again.

The expeditions of Vitus Bering

In 1725 Peter the Great, Tsar of the Russian Empire, decreed that the coast of Siberia was to be explored and mapped. Vitus Bering, a Dane serving as an officer in the Imperial Russian Navy, conducted numerous expeditions to fulfill the imperial decree. Between 1733 and 1743, Bering carried out an exploratory program of breathtaking proportions. Over the course of the "Great Northern Expedition," as it was called, Bering explored the Kamchatka Peninsula, the East Siberian Sea and the Bering Sea, then advanced as far east as the Aleutian Islands and the west coast of Alaska. The objectives of the expedition were to investigate the feasibility of a Northern Sea Route, to explore the American coast, and to reconnoiter a sea route from Kamchatka to Japan. Bering's exploits yielded highly reliable information on sea routes as well as new hunting grounds for whalers and sealers. Unfortunately the Danish captain's findings held out scant prospect of a viable NSR.

Thanks to the explorations of Bering and other officers of the Imperial Russian Navy, a wealth of geographical data on the Siberian coast was accumulated. Yet despite these efforts the Northeast Passage remained as elusive as ever. A real breakthrough would have to wait for the voyages of Adolf Erik Nordenskjöld in 1878–79.

2. Background to the NSR

The contributions of James Cook

Although James Cook was never a part of the quest for the NSR, no account of the background to the NSR would be complete without touching on his achievements. In 1778, Cook discovered Hawaii, naming the island chain the Sandwich Islands. He turned to the northeast to map the western coastline of Alaska and Canada, then passed through the Bering Strait to reach the 70th parallel before his advance was halted by sea ice. Cook was forced to return to Hawaii, where he met a tragic death. Although his crew returned to the Bering Strait, they were once again blocked by sea ice, obliging them to return to England via Kamchatka, Japan and the Straits of Malacca. Cook developed a technique to obtain highly accurate mapping results. He set a baseline using astronomical observations and mapped the contours of the coast by recording bearing and distance at a few points. To deduce the distance between points, Cook fired a gun and measured the time taken between two ships. Beginning with his second voyage, Cook added a chronometer to his toolkit, enabling him to examine the error between astronomical and non-astronomical bearings, such as the latitudinal error between measurements based on lunar distance and those obtained by astronomical observation. With this bold new technique, Cook conducted painstaking measurements of tides and ocean currents. The maps and astronomical navigation techniques Cook formed a new foundation for generations of maritime explorers to come and ushered in a great new age of British hydrography. Cook's methods and results proved invaluable in later missions to navigate the NSR.

2.1.2 From Nordenskjold to the Russian Revolution

The voyages of Adolf Erik Nordenskjold

The first mariner to successfully navigate the entire Northeast Passage was Adolf Erik Nordenskjold. Professor Nordenskjold's Vega left the port of Tromsø in Norway, traveling for over a year across the icy Arctic seas before passing through the Bering Strait in July 1879 and reaching Yokohama in September of the same year. However, Nordenskjold's motives had nothing to do with finding an NSR linking Europe and Asia. Nordenskjold was searching for two different routes. One of these, later called the Kara Sea Route, would link Europe with the Ob-Yenisey river basin; the other was a prospective passage from Europe to the Lena basin.

The tragedy of the Jeanette

During the same period, in 1879, the United States was in the midst of an aggressive territorial expansion. The American government dispatched the explorer De Long to discover a new continent in the Arctic and to reach the North Pole. Although he passed through the Bering Strait, De Long advanced no further than the 71st parallel. De Long's expeditionary vessel, the Jeanette, drifted for two years after that, and was finally shipwrecked in the Novosibirskiye archipelago. On this ill-starred voyage De Long succeeded in discovering Wrangel Island, but tragically only 13 of a crew of 33 men survived to reach the Lena River. Three years later, timbers from the shipwrecked Jeanette were found on the southeast coast of Greenland, casting doubt on the existence, widely speculated at the time, of a new continent at the North Pole. Public opinion grew increasingly negative about the entire enterprise of the search for a northern continent.

The hardships of Arctic navigation and the construction of the first icebreakers

Lured by the region's wealth of natural resources, between 1876 and 1919 as many as 122 expeditions are recorded in the quest for the Kara Sea route advocated by Nordenskjold. Unfortunately the vast majority of these voyages were not the successful commercial operations Nordenskjold envisaged, but extremely dangerous missions whose success rate was dismayingly low. Of 87 expeditions that set sail for the Ob-Yenisey basin from

1874 to 1901, only 60 reached their destination; another 22 fell short and returned to port, and five were shipwrecked. On the Siberia-to-Europe route, 36 of 42 expeditions succeeded but six foundered, and from 1901 to 1910 commercial voyages on this route disappeared completely.

The first icebreaker for the purpose of Arctic navigation was the Yermak (98m long, with a displacement of 9,000t and output of 10,000HP), built at the British port of Newcastle under the direction of the Russian Admiral S.O. Makarov. The Russians built two smaller icebreakers thereafter, dubbed the Taymyr and the Vaygach; these were used by Russia's Central Hydrographic Administration to assist in hydrographic surveying activities, and in 1913 were instrumental in the discovery of Severnaya Zemlya.

The triumphs of Nansen and Amundsen

In the recent history of the NSR, one vessel that deserves a place of honor alongside Nordenskjold's Vega is the Fram, skippered by Fridtjof Nansen. Because Nansen was a scientist rather than a commercial adventurer, his achievements are often underplayed in the saga of the NSR, but his contributions, both indirect and fundamental, were profound in terms of understanding the natural environment of the Arctic. Nansen's two-year voyage across the Arctic Ocean beginning in 1896 provided the observations that pack ice motion was always at a large angle to the surface wind (up to 45° *cum sol*), which hinted the fact that the Coriolis force must be an important factor. Nansen had ushered the concept of drift-station and intended to drift for a protracted period in the icy seas, so he developed an ice-resistant ship construction, of which the basic concept of the hull form continues to be used to this day. Nansen's innovative spirit formed the cornerstone of much of the academic research on the Arctic conducted today.

In the early part of this century a Norwegian named Roald Amundsen challenged the western Arctic. After a preliminary voyage to the west coast of Greenland aboard the Gjoa, Amundsen sailed the same vessel on a three-year expedition from 1903 to 1905 to complete the long-heralded navigation of the Northwest Passage. It is said that Amundsen, who was also the first to reach the South Pole, had been inspired by Nansen's polar explorations and his completion of the Northeast Passage aboard the Vega, and had held a lifelong ambition to open up the Northwest Passage.

2.1.3 The Russian Revolution and its aftermath

The early years of the revolution

Even during the turbulent years of the Russian Civil War, pioneers such as Admiral A.V. Kolchak continued to pursue the vision of Peter the Great, experimenting with ways of opening the Kara Sea route between Europe and Siberia. This effort soon became entangled with the construction of the Trans-Siberian Railroad, and the opening of the NSR gradually took on the complexion of a strategic military project.

The 1930s were a period of rapid and significant development for the NSR. In 1932 the Soviet Pacific Fleet merchant marine was formed, followed in 1933 by the Northern Naval Fleet; both were based on the Kola Peninsula. Battle-hardened from action in the Russo-Japanese War, these Fleets sharpened the strategic importance of the NSR. In 1932, as part of the activities of the International Polar Years of 1932-1933, an international scientific observation project traversed the NSR from west to east in a small icebreaker called the Aleksandr Sibiryakov. On this voyage, the party left the port of Arkhangelsk in July and arrived that same summer in Vladivostok, from which it continued onward to dock at Japanese shores in November. The Aleksandr Sibiryakov completed this landmark NSR journey in only a third of the time logged by the Vega. Other successes were to follow: in 1934 the Fedor Litke became the first vessel to negotiate the NSR in a single season and without a single mishap, and in 1935 the cargo ships Vantsetti and Iskra, supported by the Fedor

2. Background to the NSR

Litke, became the first craft of their kind to successfully complete the eastern NSR.

Establishment of Glavsevmorput

In February 1932 the Soviet Union established the Chief Administration of the Northern Sea Route, called Glavsevmorput, to conduct administration and management of the NSR in accordance with the Soviet national interest. This body was invested with plenipotentiary authority over the development, management, regulation and preservation of the NSR. O.Yu. Shmidt, leader of the Sibiryakov survey team, was initially placed in charge of Glavsevmorput. In 1941 Ivan Papanin, an illustrious figure in Arctic navigation, was named Head of the organization. Under the guidance of Glavsevmorput, collaboration with government agencies in conducting exploration for strategic purposes became a matter of course, and was added to the task of opening shipping routes. A series of new ports were opened during this time, including Dikson, Tiksi, Mys Shmidta and Provideniya. Four Stalin-class icebreakers were constructed and commercial fleets led by icebreakers were increased, as the volume of the Soviet Union's marine shipping volume grew from strength to strength. Unfortunately, the age of the NSR arrived just as the Second World War erupted, and the distinction between military and civilian applications for the NSR became blurred. In 1942, for example, the first Soviet naval contingent succeeded in navigating the NSR from Vladivostok to Polyarnyi with the support of an icebreaker.

Under the Soviet system, Siberia's natural resources such as grain and lumber were bartered for industrial products from Western Europe. Since no hard currency was required for this trade, The Soviet government was keenly interested in establishing a shipping route via the Kara Sea.

Although not directed at developing commercial shipping as such, some noteworthy developments took place during the Second World War. The Komet, a converted German cruiser, traversed the NSR, and military support materials were shipped from the United States through the Bering Strait to the north coast of Siberia. In addition, American Wind-class icebreakers offered long-term support to Soviet ships in the Arctic Ocean. These valuable achievements and experiences in Arctic navigation provided a wealth of data for future NSR planners to draw upon.

After the Second World War

After the Second World War ended, the Soviets grew increasingly appreciative of the value of the Northeast Passage (NSR) for reasons of defense strategy. Roughly half of the materials provisioned at the Yakutia military base, located in the eastern Taymyr Peninsula, were brought in by sea along the NSR. Beginning in 1978, the seaborne cargo route between Dudinka and Murmansk was expanded to operate year-round, carrying valuable freight such as nickel from Igarka.

In later years, the USSR committed considerable resources to NSR navigation. During the two months of December 1972 and January 1973, the 7,430 metric ton cargo icebreaker Indigirka pioneered the age of winter NSR navigation by voyaging from Murmansk to Dudinka in 12 days. Under the Soviet regime, all shipping in the Arctic Ocean consisted of either the movement of military or strategic cargo or transport for political or administrative purposes. This traffic scarcely fit the definition of shipping based on market principles, but the expertise gathered in the course of this activity was of immense value in approaching the dream of NSR commercial traffic. Data from this period was instrumental in attaining the breakthroughs that brought international NSR shipping closer to reality.

Throughout much of the 20th century the USSR labored to open the NSR with a clear eye on the national interest and the task of nation-building, as well as a keen understanding of the strategic importance of the Arctic region. Before that time, the exploration of the NSR and the Arctic had shifted gradually from efforts to wrest

hegemony over the seas from Spain to an international competition with no clear remunerative value. National rivalries, personal ambitions and scientific pursuits became deeply entangled, so that researchers such as Nansen and Amundsen became national heroes as the final chapter in European exploration of the Arctic was written.

2.2 Political and Social Background

The Soviet Union's (and later, Russia's) Siberian policy with respect to the NSR shifted numerous times over the past century. After the Russian Revolution, Peter the Great's imperial administration gave way to a Soviet regime which emphasized national defense and the creation of a nation unified under socialism. After economic upheaval and the end of the Cold War, the Russian Republic was founded and power devolved toward regional governments. The complexity of the resulting situation makes the future direction of development of an international shipping route unclear.

One of the most significant outcomes of the recent collapse of the Soviet system is the disintegration of its federal system, which had boasted strong bonds of national unity. Ostensibly, according to article 72 of the "Brezhnev constitution," promulgated in 1977, each of the Soviet Union's 15 republics belongs to the federation with the free assent of all of its various ethnic groups, which enjoy equal rights under the constitution. This meant that each constituent republic was free to secede from the Union at any time. In fact, it was assumed that such secession was never to happen, and no legal provisions were made to enable secession to occur. When the Baltic republics issued their joint declaration of secession, the Soviet federal system began to unravel, giving way to a new era of multipolarity in the international community that required the adoption of a new doctrine to handle relations among the republics. Secretary General Gorbachev had set the stage for this realignment at the Warsaw Pact Summit in July 1988, when he renounced the Brezhnev Doctrine, advocating a new approach linked with the program of perestroika ("national reconstruction"). Gorbachev envisioned a new interdependence among economic and environmental issues that transcended the conventional systems of socialism and capitalism, giving precedence to values common to all peoples. Issues of national security were to be determined through due political process. Military resources were to be streamlined, so that a military capability sufficient for defensive purposes would be deemed adequate. In short, Gorbachev's goal was to strip ideology out of international relations.

In an address in Murmansk on October 1, 1987, Gorbachev declared the NSR open as an international shipping route. This did not signify the opening of the seas to all comers, but it did represent an end to the old, cold-war mechanisms previously in place. At the very least, Gorbachev's declaration constituted a recognition that the NSR had lost most of its strategic/military value. In fact the NSR declaration was inevitable, given the Soviet Union's urgent need to recover from its long and steep economic decline that began in the latter years of the Brezhnev regime, and in particular to build up the country's depleted foreign-currency reserves.

Gorbachev's dream of a federation of sovereign Soviet republics was dashed in August 1991, when an attempted coup d'état was crushed. The aborted coup hastened the republics' bid for independence. The Communist Party, whose existence was inextricably bound to the authority of the federation, was dissolved. These events also strengthened the hand of Boris Yeltsin, elected President of the Russian Republic in June of the same year, who seized the opportunity to break Russia away from the old Soviet system.

Russia convened a National Council, composed of the President of the old Federation and the leaders of each of the republics, in a bid to create a replacement for the supreme decision-making body that had just been swept away. It was hoped that, by recognizing the independence of the Baltic countries and starting afresh, a new federal treaty could be concluded. This effort reached an impasse, however, when elements of Ukraine's brittle ruling alliance rejected it. Next a treaty on economic union called the Commonwealth of Independent

2. Background to the NSR

States (CIS), aimed at defusing an economic crisis and effecting the transfer to a market economy, was mooted among 11 of the republics (the Baltic countries and Georgia did not participate). This organization continues to press forward in the direction of a market-based economy today. However, the formation of the CIS did not smother all of the discord caused by these upheavals, and the flames of dissent continue to smolder throughout the old federation. Confusion on the Russian political scene continues to frustrate the smooth implementation of commercial operation in the NSR. A power struggle continues between the center and the regions. Boris Yeltsin, the first popularly elected head of state in Russian history, attempted to centralize political power in Russia, but this scheme was thwarted in the face of strong regionalism. In 1997 the President lost the power to appoint most of the governors of Russia's constituent states and regions, as these public figures came to be directly elected. This tug of war between centralism and regionalism seems set to swing back and forth for the foreseeable future.

This expansion of regional autonomy in Russia makes it necessary to clarify the benefits the NSR brings to each affected region. Therefore, the international community must be made aware of the planning scenarios under development, how the project will be funded, which organizations will implement the project and bear the risk, and what the time-frame will be, with respect to the infrastructure that will have to be built to render the NSR usable and the issues regarding preservation of coastal environments. Ironically, the development of the NSR benefited richly from the Cold War and the Soviet system, which provided generous navigational infrastructure. This was made possible by highly disciplined cooperation between the civilian, military and scientific sectors, which operated on an equal footing and on their own terms.

2.3 Economic and Shipping Background

The onslaught of perestroika and glasnost ("openness" in government) was preceded by a Russian economy in imminent danger of complete collapse. The government was under tremendous pressure to adopt radical measures, including granting permission for the formation of private companies. It was soon recognized that the conditions underpinning the switch from state-owned to privately owned enterprises, such as the rights to earn profits, raise funds independently and elect enterprise leaders, would come to naught if the reforms did not extend to political restructuring as well. A rapid-fire battery of legislation—such as the Law on Individual Labor Activities and the Law on Joint-Venture Companies, passed in 1987, and the Law on Cooperative Associations, promulgated in 1988—provided a framework for these new enterprises to operate in. At the same time as these economic reforms were being carried out, however, the ruling party overseeing them was riven with strife. Russia lurched into political chaos before the effects of these reforms could be realized, throwing its economy deeper into disarray.

During this period of confusion, each of the former Republics featured a dual economy: an official economy and an underground one. In Russia, the old planned economy, or centrally run economy, continued to run Soviet-style economic activity with strong centralization of power and strict control according to a centrally determined plan. Little room was left over for free competition based on market principles. Parallel to the official economy, the underground economy was formed from the various commercial, service, transportation and distribution sectors that had always been looked on with contempt under the command economy. To the government, these activities consisted of nothing more than illegal black-marketeering. As the Russian Federation shifted toward a market economy, however, this underground economy (except for areas tainted with criminal activity) rose to the surface, and its commercial, service, transportation and distribution sectors quickly became the most vigorous part of the economy of the new Russia.

Under Boris Yeltsin, the Russian economy was torn apart by the President's "shock therapy" tactics. After

three years of spiraling economic contraction that ended in 1992, the Russian economy continued to exhibit negative growth from 1992 to 1996, and the government's financial position steadily deteriorated. By the end of this period Russia had struck rock bottom. Fortunately for the embattled republic, buoyant overseas demand for Russia's main industrial products—steel, non-ferrous metals and oil—prompted an economic recovery that started in 1995. Signs of revival were coupled with tamer inflation and signs of stability in the exchange rate of the ruble, and the government's "general investment program" fuelled hopes for growth in 1996 and subsequent years. Unfortunately predictions of growth in 1996 proved premature, underscoring the impression that Russia's economic comeback was no more than a flash in the pan. Part of the blame must be laid on the failure of Yeltsin's economic policies, but a principal underlying cause must surely be the IMF's obstinate and draconian tightening of domestic finance. Although the Fund's harsh restriction of the money supply was successful in squeezing inflation out of the economy, this policy also choked off investment and ground enterprises' productive activities to a halt. At the same time, high interest rates swelled outstanding debts between enterprises, creating instability in the credit system and exacerbating the problem of non-payment of workers' wages. In turn, this situation throttled the flow of tax revenues into government coffers. The importance of other factors cannot be denied as well, such as pork-barrel spending in the runup to a presidential election and vast military expenditures on the protracted war in Chechnya.

Russia is one of the most resource-rich countries in the world. If it cannot easily earn foreign exchange with its industrial products, Russia can generally rely on exports of its natural resources, in either raw or primary-processed form, to support economic growth with hard currency. Gradually, however, a sense of opposition and alarm is rising to the surface, regarding the depletion of Russia's precious natural resources by foreign powers.

Other problems, familiar around the world, arise in connection with resource extraction in Russia. Resource development is often opposed on the grounds that the extraction and transportation of natural resources may uproot the indigenous communities that dot Siberia's landscape from their traditional living environments. Many assert strongly that Russian law must offer complete protection of the rights of indigenous peoples. The conflict among the expectations of various groups can be exceedingly complex. In the Ob/Yenisey/Lena river basin, for example, negative aspects such as the impact on indigenous peoples and dependence on foreign investment are weighed against positive effects such as a stable supply of consumer and other goods. A policy of self-sufficiency is not the most optimal approach for promotion of development in remote areas. Add to these the tension between the federal and regional governments and the expectations and concerns of local communities, and it is clear that there are as many perspectives on resource development as there are people. Expectations for the organic linking of regional shipping with the NSR will be anything but simple.

Foreign investment in Russia fluctuates too wildly to allow any reliable forecast to be made, but it would surely grow rapidly if a stable system of taxation could be established. Russia's foreign-exchange controls are far feebler than most countries, making it easy for illegal capital outflows to hobble economic growth. According to the June, 1997 issue of *Izvestiya*, illegal capital outflows from Russia amount to US\$12–15 billion per year. Hard currency earned from exports of oil, non-ferrous metals and the like are not circulated in the Russian economy but are secreted out of the country and into Western countries or offshore tax havens. Although Russia's external balance of payments from 1992 to 1997 was positive, much of this surplus failed to flow smoothly back into the country.

The widening gap between rich and poor, symbolized by the arrival of the "new rich," and the hardship of Russia's pensioners are serious problems of Russian life well publicized in the West. On the other hand, although largely limited to major urban areas, consumer goods and foodstuffs are becoming increasingly

2. Background to the NSR

available, leading to the formation of a class of middlemen that purchases and resells these goods. Many of Russia's imports and exports are conducted through third-country markets; these new channels provide a solid boost to purchases of cars and office automation equipment from abroad. It is important to recognize these undercurrents for the significant indicator of economic recovery that they are.

The economic meltdown in Russia naturally struck a near-lethal blow to maritime shipping, which had once been expected to benefit most from the shift to a market economy. Russian territorial waters were divided into two zones, East and West. The two state-owned shipping companies, Murmansk Shipping and Far East Shipping, were privatized, and a number of companies of various sizes were established, under the worst possible conditions: Russia's GDP and trade volume were both shrinking, shipments of strategic materials were in freefall, and economic difficulties throughout Russia were reducing or even halting demand for shipment of materials in every region. These firms were founded just as shipping companies worldwide were busily streamlining and downsizing, with no prospect of a turnaround in global business conditions. Given the lack of credible scenarios for recovery and the battery of problems these enterprises faced, Russia's northern ports overflowed with ships that stayed moored and never put out to sea.

Although the Murmansk and Far East Shipping Companies continued to divide their spheres of operation along east-west lines, as each enterprise moved toward operating under market-driven principles it gradually became clear that the Murmansk company, handling by far the more profitable market, had the strongest voice in the development of the NSR. Nonetheless the profitability of the Murmansk outfit is in doubt as well. It is supported by a public commitment from the Russian government to subsidize the operation of its nuclear-powered icebreakers; with opposition to such funding on the increase, its ability to increase its opportunities to use these icebreakers, whose profitability is assured, has become a question mark. Although the full-fledged opening of the NSR raises a host of questions regarding insurance fees and so on, it would also clearly be the "killer app" that rescues the Russian shipping industry.

In opening the NSR, the following conditions must be met before all else. Russia's shipping industry must not be a party to the illegal outflow of Russian assets to other countries. It must take part in the economic recovery of Russia through its own efforts, in the context of a national policy that is acceptable to the international community. Finally, it must abide by its financial promises, under a legal framework prepared on the basis of market principles.

2.4 Technological background

The NSR presents the challenge of one of the most forbidding natural environments on earth. To overcome this obstacle, the following minimum technological conditions must be met.

- * Information on weather and ice conditions must be available to a sufficient standard to ensure the safety of navigation and enable optimum routing.
- * This information must be made available on each voyage both in advance and on a real-time basis.
- * Navigation methods appropriate to all ice conditions must be established.
- * Technology must be established to enable the design and construction of ships with excellent capability for safe transit in ice-infested waters.
- * Technology must be established to enable the design and construction of the most appropriate and efficient support icebreakers.
- * Land bases and other fundamental infrastructure must be established with navigational support and rescue facilities.
- * Facilities and/or systems must be established to provide training for navigation in polar ice-covered

waters.

Thanks to the policy of "glasnost", Russian data on weather and ice conditions in the Arctic Ocean are steadily becoming available, and unprocessed data are expected to be analyzed through international collaboration. Through collaboration in the field of physical oceanography, the development of appropriate provisions is expected to proceed apace as the results of new observations are revealed.

The development of real-time delivery of navigational information is in the implementation phase, as the full capability of satellite remote sensing technology comes on stream. With future progress in sensing technology, new satellites will be launched into polar orbit, making the dream of establishing optimum routing in polar ice-covered waters a reality.

To provide the technology to design and construct ships capable of navigating icy waters, both profitability (cost-performance) and design specifications must be taken into account. The practicality of Arctic operations has been demonstrated on numerous occasions, and the currently established level of navigational performance is sufficient to make those operations practical. Of course, the pursuit of continued improvement of ice-transiting performance of ships is a never-ending technical quest, with no final goal. A certain amount of further research will be needed to determine the required design, since the specifications depend on the operational mode of the vessel, which in turn depends on the frequency of icebreaker support and the kind of support needed.

In principle, NSR shipping will have to depend exclusively on Russian icebreaker support. From the era of the Russian tsars through the Soviet era to the present day, Russia has conducted an uninterrupted program of research and development in icebreaker technology. Constant improvements have made Russian icebreakers some of the best in the world. With the exception of special technical problems with respect to the navigational support of Western vessels, it is recommended that Russian icebreaker technology be used for the time being, regardless of evaluations of the cost-performance of Western designs.

Overall implementation of the infrastructure required for land-based navigational support facilities and equipment and rescue facilities is difficult to forecast at this time. Unless investment in these facilities comes from abroad, very little new installation can be expected over the near term. If navigation is only carried out during the summer, when the dangers are relatively few, it is probable that, as Russia asserts, there are no absolute conditions requiring the installation of such facilities, barring the occurrence of sporadic and unforeseeable accidents. However, ice conditions are known to vary dramatically over the course of any given year, so even in summer navigation unforeseen hazards can occur. Specific scenarios for infrastructure implementation should therefore be carefully prepared. Moreover, although crisis management measures are already prepared to handle incidents of marine pollution caused by accidents, specific action plans to prevent and eliminate pollution leave some room for uncertainty, and the possible damages and fines are difficult to estimate.

NSR operators must be highly experienced in icy-water navigation. In particular, operation of vessels with the support of an icebreaker is a highly specialized mode of navigation, requiring a seasoned hand in painstaking, moment-by-moment judgment of operating conditions. Ensuring that NSR crews have sufficient experience is extremely important, and training with navigation simulators may be needed. In view of the prevailing customs in the shipping market, and given the vast distances that must be navigated and the inordinately long travel times involved, it will likely be difficult to enlist sufficiently skilled guides for NSR crews.

Present conditions are not conducive to the smooth implementation of NSR shipping. Russia remains in economic turmoil, and the conditions listed above have yet to be satisfied. Given a recovery in Russia's

2. Background to the NSR

economic fortunes, however, several of these criteria may be met over the short term. In the near future, most icy-water shipping will surely be based on satellite technology; in this sense, preparation for the age of NSR shipping is already well under way.

3. Natural Conditions in the NSR

3.1 Natural Conditions in the Arctic

The natural conditions prevailing in the NSR are utterly different from those anywhere else in the world where commercial shipping is conducted, with the possible exceptions of the Bay of Bothnia, the Gulf of St. Lawrence and the Great Lakes. Accordingly, ship design and construction, observation of ice conditions, navigation support systems and navigation plans must always carefully reflect the natural conditions both at sea and on land. Needless to say, the Arctic is also vitally important in terms of the earth's environment; any human activity in the region, including navigation, must presume a careful understanding of the nature of the Arctic, meticulous environmental impact assessment, and a comprehensive response to that assessment.

3.1.1 Physiography of the Arctic Ocean

The Arctic Ocean consists of a deep ocean basin, submarine ridges, continental shelves, and marginal plateaus. Five major epicontinental seas, the Barents, Kara, Laptev, East Siberian, and Chukchi seas, are located on the broad European and Siberian continental shelves. The Arctic Ocean is a sea with an area of 14 million square kilometers surrounded by the continents of Eurasia and North America and the vast island of Greenland. The Scandinavian Peninsula is separated from Greenland by a distance of 1,400km, which contains a deep abyssal plain 3,500m deep. The eastern end of this part of the Arctic Ocean, which abuts the North Atlantic Ocean, is called the Sea of Norway, while its western end is known as the Sea of Greenland. The Arctic Ocean opens to the North Pacific Ocean through the narrow passage of the Bering Strait, an 80km gap between the continents of Eurasia and North America. The Bering Strait is extremely shallow, being no deeper than 60m at its deepest point. The strait between Greenland and Ellesmere Island in Canada's Arctic Archipelago is roughly 20km wide and extends to a depth of 500m. This body of water leads through Baffin Bay and Davis Strait to the North Atlantic Ocean.

In the center of the Arctic Ocean, a deep abyssal plain stretches out 4,000m below the surface of the ocean, with its deepest point extending 5,440m below sea level. The seabed that extends from the northern tip of Greenland across the North Pole to the Novosibirskiye Ostrova (Islands) of Russia features a ridge called the Romonosov Ridge, which divides the Alaska side of the ocean from the European side. Other ridges lie roughly parallel on either side of the Romonosov Ridge. The ridge on the Northern European side of the Romonosov Ridge is called the Arctic Mid-oceanic Ridge (or Nansen-Gakkel Ridge), and the ridge on the Canadian side is named the Alpha Ridge. Approximately 70% of the Arctic Ocean is over 1,000m deep; the remaining 30% consists of a broad continental shelf. The European-Siberian continental shelf extends far into the Arctic, while the North American continental shelf is much narrower. The Beaufort and Lincoln



The Arctic ocean

3. Natural Condition in the NSR

Seas include areas over 1,000m deep.

The European-Siberian continental shelf is dotted with a series of island chains. These include, from west to east, the Svalbard Islands, Zemlya Frantsa Yosifa, Novaya Zemlya, Severnaya Zemlya, the New Siberia Islands and Wrangel Island. On the North American side, no islands are found far from shore; the islands of Canada's Arctic Archipelago, such as Banks Island, Queen Elizabeth Island and Ellesmere Island give shape to the Arctic Ocean off Canada's northern coast.

3.1.2 The Midnight Sun and Temperatures in the Arctic Ocean

Apart from a tiny sliver of ocean near the Bering Strait, the entire Arctic Ocean is located within the Arctic Circle, north of 66° 33'N. Because of its location at the North Pole, there are days on which the sun never sets, and others on which the sun never appears above the horizon. As one moves closer to the Pole, these "arctic days" and "arctic nights" increase in number. The vicinity of the Laptev Sea coast (72.5°N), for example, is witness to 88 arctic days and 76 arctic nights. Even further north, the north coasts of the Svalbard and Zemlya Frantsa Iosifa islands (80.3° N) are witness to 138 arctic days and 126 arctic nights. The reason why the numbers of arctic days and arctic nights are uneven is that the sun's rays can be seen when it is still 0.5° below the horizon, due to the refraction of light.

The heights of the arctic-day and arctic-night seasons are the summer and winter solstices respectively; as the seasons shift to spring and summer, the number of hours of sunlight changes in a symmetrical fashion away from the extremes of the solstices. Although the sun is much lower than in the equatorial zone, the Arctic Circle receives sunlight 24 hours a day around the time of the summer solstice, and total solar radiation per day at this time of year is therefore higher than in the equator zone where the sun shines only half the day. This bounty of sunlight, however, does not cause temperatures to soar during the polar summer, as its unique cloud and fog formations block off the light and polar snow and ice reflect most of the radiation back into space.

The annual maximum and minimum air temperatures at the Arctic Ocean surface occur roughly one month after the summer and winter solstices, in July and January respectively. Average air-temperature distributions in July cover a broad range on the above-zero side and even up to 8 near the coast, except for the center of Greenland and of the Arctic Ocean. In the center of the Arctic Ocean, where multi-year ice remains frozen throughout the year and some melting occurs at the surface during the summer, such process of the massive multi-year ice stabilizes the temperature of the air around 0°C.

In January, on the other hand, the coldest regions are the Siberian and Greenland coasts, gripped by

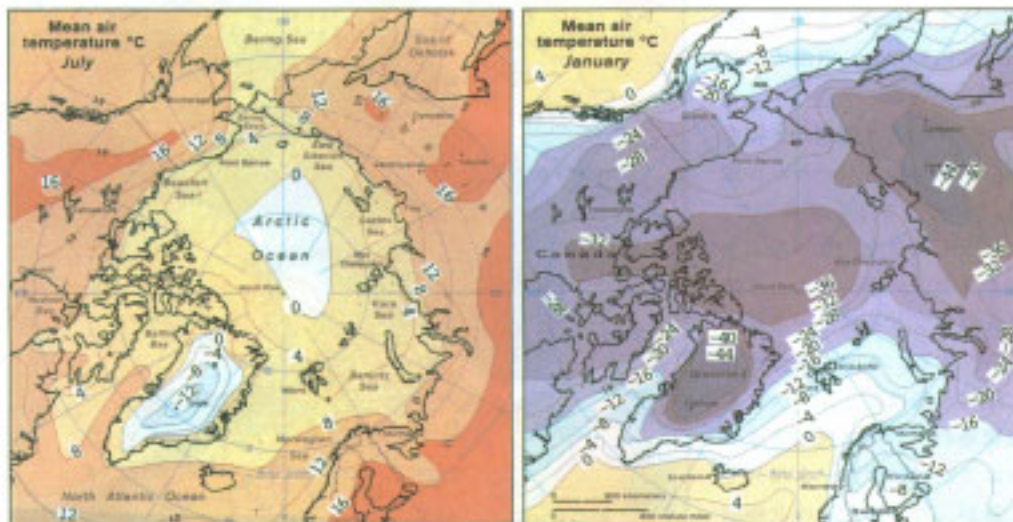

Average monthly temperature distribution (left:July, right:January)(Revised from the Polar Regions Atlas

temperatures in the range of -44°C . Average temperatures plunge to around -36°C at the center of the Arctic Ocean and about -32°C in Canada's Arctic Archipelago. The ocean from the Sea of Norway to the Barents Sea is warmed by the Gulf Stream, so the surface does not freeze even during the arctic nights. Temperatures in this region are a striking 30°C warmer than at the center of the Arctic Ocean.

3.1.3 The Aurora Borealis and Magnetic Storms

The aurora was named after the Roman goddess of the dawn, who chased the darkness away and led humanity into the light. The aurora appears near each of the poles; the northern aurora is called the aurora borealis and the southern aurora is called the aurora australis.

The surface of the sun often sets off massive explosions called flares and emits a violent storm of ions from a zone at the surface called the corona. These emissions form a "solar wind" of particles that travel rapidly outward in all directions. The solar wind is a form of matter known as plasma: charged protons and electrons stripped from hydrogen atoms. This current traverses the 150 million kilometers from the sun to the earth in about three days, traveling at about 450km/h by the time it nears the earth. Because the earth has a magnetic field, the solar wind is deflected around the earth along magnetic field lines and is thus prevented from breaking through the magnetic field and reaching the earth's surface. The earth and its magnetic field together form a zone called the magnetosphere, which is bent away from the sun by the solar wind, forming a shape rather like the tail of a comet. The solar particles thus flow away around the earth's magnetic field. Through the interaction of the solar wind and the magnetosphere, a powerful electric generator is formed, generating more than 100 billion watts of electricity. This enormous current guides the plasma along lines of magnetic force from behind the earth to the Arctic and Antarctic zones.

The aurora is generated in the extreme upper reaches of the earth's atmosphere, 80km from the surface. The atmosphere at this level is as close to a vacuum as the space inside a neon tube. The plasma from the solar wind excites the oxygen and nitrogen atoms, creating a discharge illumination effect much like that used in neon tubes. The colors of the aurora differ according to the type of atoms struck by the plasma and the distance from the earth. The most commonly seen auroras, with their characteristic greens and blues, are generated by the illumination of oxygen atoms at a relatively near 110km from the earth's surface. At 400km, oxygen atoms emit light in the dark-red part of the spectrum, creating a "red aurora." Ionized nitrogen atoms emit a blue light at 90–150km, and at 90km neutral hydrogen molecules appear as a beguiling pink. The aurora thus appears as a



Aurora borealis



Aurora australis (reverse image of a whirlpool)

(Photo: National Institute of Polar Research)

3. Natural Condition in the NSR

multicolored curtain many miles high, colored red at the top, green and blue in the middle and reddish-purple and pink at the bottom.

The aurora borealis is formed in a region called the aurora belt around the magnetic north pole (located at 78.6° N, 70.5° W), at a “magnetic latitude” of 65–70°. Iceland and Japan’s Showa Station in Antarctica are located below the aurora borealis and australis belts, respectively. Despite the vast distances that separate them, however, people in both locations can see similar auroras at the same time, since they are generated along the same magnetic lines. Sometimes the auroras are mirror images of each other, looking like a whirlpool as seen in a mirror, but often the two do not much resemble each other.

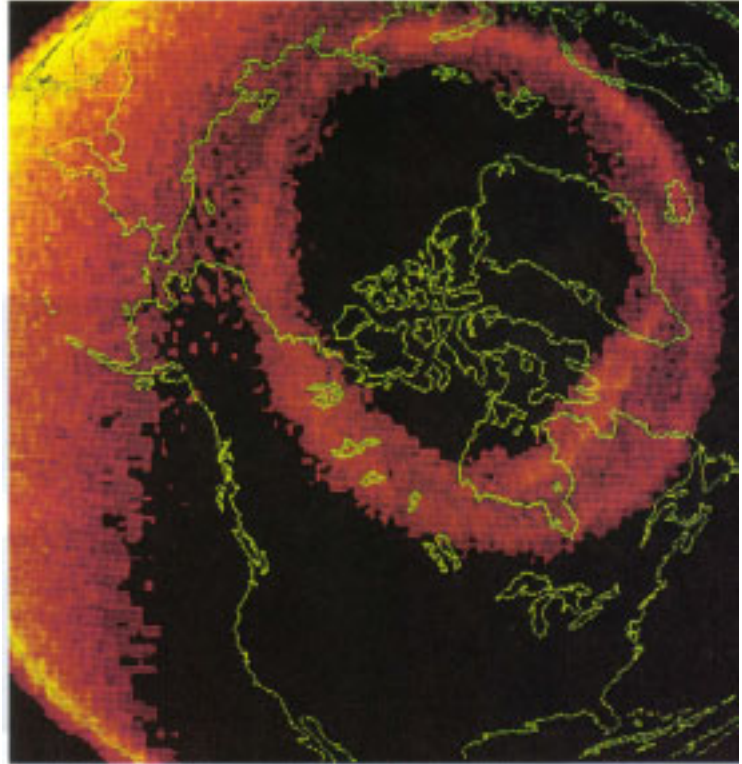

Aurora borealis oval (“Two Poles,” Rika nenhyo Dokubon, Maruzen)

Circling in an elliptical orbit high above the earth, aurora observation satellites record images of the aurora from above. These images exhibit the aurora generated during the day, which cannot be viewed from the earth’s surface, providing a view of the entire aurora. The ring in which the aurora forms is called the aurora oval. At night, this oval roughly corresponds with the aurora belt, but during the daytime it contracts to a position inside the belt, at a magnetic latitude of 75–80°. The NSR region along the Eurasian coast lies below the aurora belt, so outside of the arctic-day season, if the weather conditions are right, the NSR will be an ideal place to enjoy the aurora.

Life on earth would be impossible without the magnetosphere: It prevents plasma and deep-space radiation from reaching the earth’s surface. However, the plasma guided along the earth’s magnetic lines and ejected on the side of the earth opposite the sun has a dramatic effect on short-wave transmissions, maritime wireless communications and even high-voltage power lines. In the event of a major solar flare, the aurora becomes highly excited and the magnetosphere is deformed. These large fluctuations in the earth’s magnetism are called magnetic storms. Magnetic storms create an induced current along power lines and oil pipelines under the aurora, and have been known to overheat transformers in Canada, causing massive power failures, and to corrode oil pipelines in Alaska and Siberia. Because the NSR is directly within the aurora zone, a strong magnetic storm could render satellite positioning and satellite broadcast of ice-flow data inoperative, and even damage electronic equipment aboard vessels.

3.1.4 The Ozone Hole at the North Pole and the Increase in Harmful UV Radiation

Most of the ozone (O₃) in the earth’s atmosphere is concentrated in the stratosphere. The greatest concentration is found at an altitude of 20–30km, where ozone levels are ten times the concentration at the surface. This zone is called the ozone layer. The ozone layer completely envelops the earth, protecting it from harmful ultraviolet (UV) radiation.

In the 1970s, scientists indicated that chlorofluorocarbons (CFCs) had the capacity to completely eliminate the ozone layer. Because of its vital protective role, it was recognized that depletion of the ozone layer would have serious consequences, such as increased incidence of skin cancer and declining crop yields, and a movement to ban all CFCs began. By the 1980s, observations at Japan’s Showa Station demonstrated an unusual decline in the ozone layer at the South Pole, confirmed by data from other nations’ Antarctic outposts as well, which came to be called the “ozone hole.” This phenomenon was observed at the North Pole as well in the 1990s. Presently the ozone hole is linked to formations called polar stratospheric clouds (PSCs), and it is believed that chlorine oxides (ClOx), a key constituent of CFCs, is the agent that destroys the ozone layer.

If the entire atmosphere were under a uniform temperature of 0°C and pressure of 1 atmosphere, it would have a thickness of 8,000m. The thickness of ozone if gathered in a similar fashion is used to define the total quantity of ozone; this quantity is recorded in Dobson units, named after the ozone-layer researcher G.M.B. Dobson. Under normal conditions, total ozone volume is 300–500D.U. At the South Pole, however, ozone volume is observed to be only 120D.U. Observations at the North Pole indicate a quantity of 250D.U. Ultraviolet light is divided into three wavelengths. From the wavelength closest to the visible spectrum, these wavelengths are long-wave UV (UVA: 400–320nm), medium-wave UV (UVB: 320–290nm) and short-wave UV (UVC: 290–200nm) (“nm” stands for “nanometer”). Of these three classes of solar UV radiation, UVC is completely absorbed by the ozone layer and does not reach the earth’s surface. In contrast, most UVA radiation escapes the ozone layer to reach the earth, while the quantity of UVB that reaches the earth varies with the expansion and contraction of the ozone layer. In one example of UVB research, the volume of ozone recorded over the Greek city of Thessaloniki was plotted against the quantity of UVB reaching the earth, or “incident UVB,” there in the 1990s. A strong negative seasonal correlation was found; moreover, ozone volume steadily decreased during this time, while the quantity of incident UVB steadily increased.

Exposure to UVB radiation has been indicated as a cause not only of skin cancer and reduced crop yields as described above, but of damage to DNA as well. Research into the mechanisms behind this phenomenon, its prevention and treatment are being stepped up, and researchers are placing high priority on observing ozone volume and quantity of incident UVB in the northern hemisphere. Although it is not yet clear what the long-term effects of human activity will be on the hole in the ozone layer, researchers are determined to find a way to eliminate the hole.

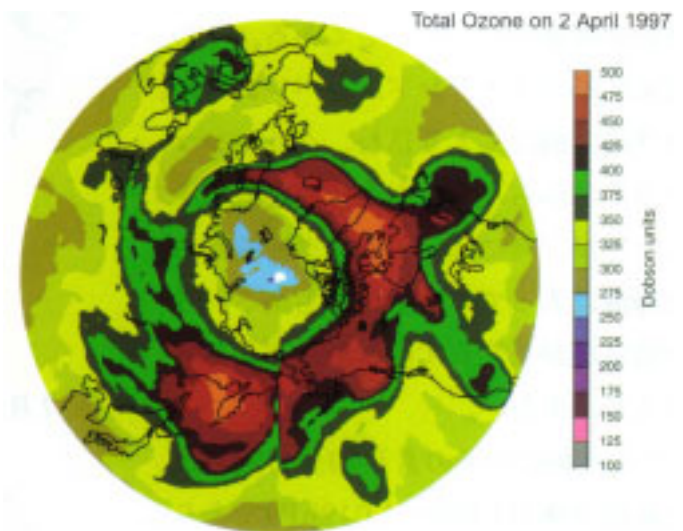

Ozone distribution in the northern hemisphere (NASDA/NASA,1998)

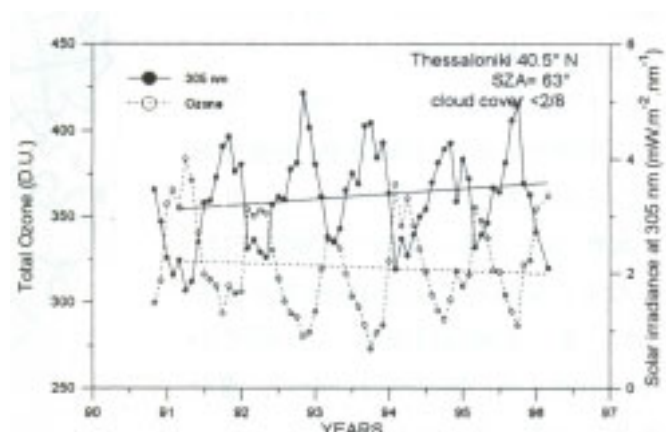

Yearly changes of total ozone and solar irradiance at 305mm(UVB) (Zerefos,1997)

3. Natural Condition in the NSR

3.1.5 The Arctic Air Mass and Tracks of Polar Cyclones

An overview of the circulation of air in the Arctic reveals that a lower, cold air mass moves south (outward from the Arctic region), while a higher jet stream moves toward the Arctic from the periphery. In the air 3–10km above the surface in the Arctic, the prevailing westerly winds flowing toward the center of the Arctic Ocean create a low-pressure circulation system. The general westerly air circulation around the cold-cored low pressure area is a result of the large temperature gradient between the equator and the poles, and of the Earth's rotation. Average annual air pressure at sea level in the center of the Arctic Ocean is 1,015.7hPa, with monthly averages of 1,011–1,020hPa exhibiting a continuing weak high-pressure area. Very little precipitation occurs in this region. High pressure prevails roughly one third of the time in the Arctic, with low pressure dominant in the remaining two-thirds of each year.

A look at the distribution of average air pressure at sea level for the month of January reveals that no high pressure occurs in the Arctic Ocean during this month. However, a high-pressure band extends through Siberia and Alaska from the center of the Arctic Ocean to the Bering Strait. In the diagram at right, the most common track for the low-pressure is indicated in a solid line and the secondary track is shown in a dotted line. The winter low-pressure (cyclone) travels from Iceland toward the Barents and Kara Seas. Another low-pressure mass spreads from northern Greenland to the Barents Sea, and sometimes a low-pressure appears traveling from the Bering Strait into the Arctic Ocean. The precipitation brought in by these low-pressure systems in winter is far less than the precipitation observed in summer.

In the diagram of the distribution of average air pressure at sea level for the month of July, air pressure for the entire Arctic Ocean is remarkably uniform, varying in a narrow range between 1,010hPa and 1,012hPa. Occasionally low-pressure masses enter from the periphery, and those from the North Atlantic, Russia (west of the Urals) and Siberia, carry a lower average air pressure of about 995hPa. The other low-pressure masses, arriving from Alaska, the Bering Strait and Canada, are somewhat weaker and feature air pressure of roughly 1,002hPa. Although summer in the Arctic Ocean tends to be free of strong winds, clear skies are rare and fog is common.

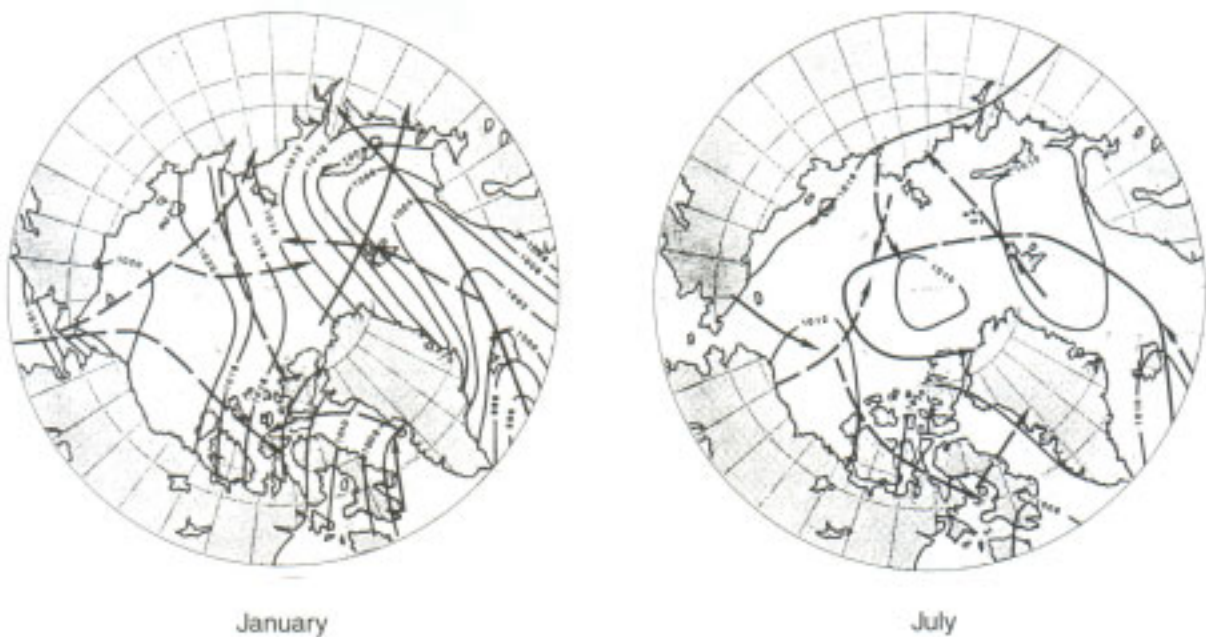

Average air pressure at sea level in January and July (Barry,1989)

3.1.6 Arctic Stratus (Clouds) and Arctic Haze

The Arctic Ocean is often blanketed in low-lying clouds called arctic strati, which sometimes descend to surface level to become fog. The average monthly frequency of arctic stratus formation in the Arctic Ocean ranges 20–40% from region to region in the winter months from November to April and 70–80% by region in the summer months from June to September. In the center of the Arctic Ocean the phenomenon is especially pronounced, with average cloud frequency in the 80–90% range from June to August, of which some 70% consists of arctic strati. In the era of visual aviation, the region was impassable in two-thirds of the summer months: an average of 18 days in June, 23 days in July and 22 days in August. In the winter, the number of impassable days fell to one third of each month.

In the spring, the Arctic is often covered in a smog called Arctic haze. Whereas on clear days in the Arctic the horizon is visible at a distance of 200km, when the Arctic haze settles in visibility is cut to 3–8km. When samples of the Arctic haze were analyzed, the results revealed that the haze is the consequence of human activity, containing large quantities of sulfuric acid, soot and organic materials. In the spring, the concentration of fine particles suspended in the atmosphere is equal to that in many urban areas. Because precipitation is low from winter to spring in the Arctic Ocean, the atmosphere is unable to clean itself through the precipitation cycle during this time. It is only in the summer months of July and August, when the mist and precipitation increase, that the arctic haze lifts, leaving the Arctic air clean through the summer and fall.

The significance of this pattern for NSR navigation is that, in the narrow straits between islands and in shallow bays, NSR shipping will depend on radar and satellite guidance for much of the year. Many routes follow low-lying coastlines, and in summer visibility is poor on many days.

Problems such as these that are associated with the Arctic atmosphere must be understood in terms of the behavior of aerosols in the polar atmosphere. Aerosols, generated by human activity and carried to the polar

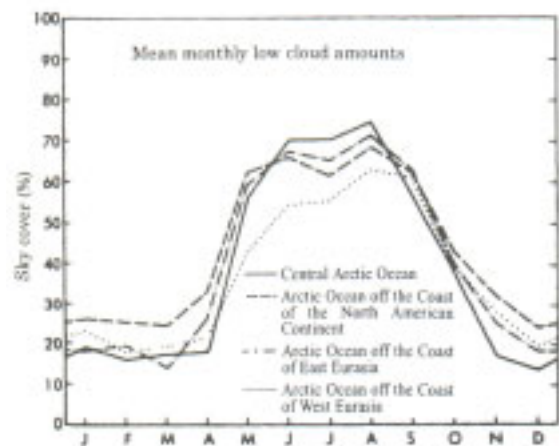

Mean monthly low cloud amounts(Herman,1986)



Arctic stratus on Spitsbergen (Photo:National Institute of Polar Reseach)

3. Natural Condition in the NSR

regions, are likely to form in the atmosphere when the density of gases surpasses the critical pressure required for solidification; this can occur in conditions conducive to increasing the gas density or susceptible to cooling to extremely low temperatures. It is this latter condition that causes the condensation of aerosols in the Arctic.

3.1.7 Seasonal Changes in Albedo

The rate of reflection by the earth's surface of incident solar radiation is called albedo. The average albedo for the entire surface of the earth is 30%, and different types of surface carry different albedo values. For example, the surface of the ocean has an albedo of 8–10% when the sun is high; grassland has an albedo of 15–25%; and desert has an albedo ranging anywhere from 20% to 45%. The albedo of snow and ice also varies widely, depending on a number of factors. The albedo of fresh snow is extremely high at 75–90%, while that of wet snow pack is lower at 40–60%, and sea ice not covered by snow has an albedo of 30–45%. Considering the low albedo of open sea, green terrain and desert, it is clear that the regions covered by snow and ice are responsible for raising the earth's average albedo to 30%. Moreover, the albedo of snowy surfaces varies considerably according to the characteristics of the snow; as the following table indicates, this variation is in the range of several tens of percent.

Albedo of various types of snow (Radionov, 1997)

Snow State	Moisture and Color	Ave.	Max.	Min.
Fresh snow	Dry, bright-white, clean	88	98	72
	Moist, bright-white	80	85	80
Fresh drifted snow	Dry, clean, slightly compacted	85	96	70
	Moist, gray-white	77	81	59
Snow which fell drifted 2 - 5 days previously	Dry, clean	80	86	75
	Moist, gray-white	75	80	56
Compact snow	Dry, clean	77	80	66
	Moist, gray-white	70	75	61
Recrystallized snow and ice	Moist	63	75	52
	Dry, gray-white	65	70	58
Saturated with water	Light-green	35	-	28

When we look at the difference in albedo between winter and summer at each latitude in both hemispheres, we see that no seasonal variation occurs at the lower latitudes or on the permanently frozen Antarctic ice sheet. The regions where significant variation in albedo occurs between summer and winter are areas of snow cover in the Northern Hemisphere where snow accumulates only in the winter and the fringes of the Antarctic continent where the ice cover expands during the winter. The albedo of the multi-year sea ice areas in the Arctic Ocean changes seasonally because the sea ice surface melts in the summer.

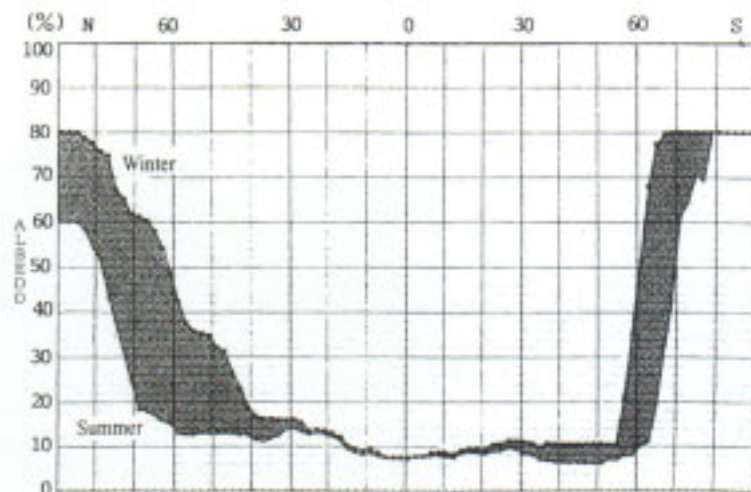

Latitudinal and seasonal variations of albedo(Ono, 1995)

3.1.8 Glacial Periods and Ice Sheets in the Northern Hemisphere

The ice age that began 350,000 years ago has completed four cycles of alternating glacial and interglacial periods. We are currently in the midst of the last interglacial, which began several thousand years ago and is known as the “postglacial period.” During the glacial periods the ice sheets expanded over the earth’s continents. Because the ice sheets absorbed water that would otherwise have been returned to the oceans, the sea level dropped and the continental shelf jutted above the ocean’s surface. Because the ice sheets were not able to melt completely during the interglacials before the onset of the next glacial, the sea level dropped with each repetition of the glacial phase of the cycle. In the final glacial period, when the sea level reached its lowest point, the sea level is estimated to have been fully 120m below its present level.

Some 20,000 years ago, during the last glacial period, the ice sheet that covered Scandinavia extended north across the entire continental shelf from the Svalbard Islands to Frantsa Josifa and Severnaya Zemlya, west across all of the British Isles and east almost to the Taymyr Peninsula. In North America, the Laurentide Ice Sheet covered almost all of Canada and extended from Greenland in the north to the Great Lakes on its southern fringe. The ice sheet west of the Canadian Rockies, known as the Cordilleran Ice Sheet, followed the southern Alaskan coastline to the Aleutian Islands. With the drop in sea level that attended the glacial period, the continental shelf under the Kara, Laptev and East Siberian Seas was exposed to become dry land. Moreover, a wide swath of ocean from the Chukchi Sea to the eastern part of the Bering Sea rose above sea level, linking Eurasia and the Americas in a vast land region called Beringia. It is believed that the prehistoric Mongoloid crossed this land bridge and reached South America.

The region from the Taymyr Peninsula across Beringia to northern Alaska was not covered by an ice sheet but was exposed to bitterly cold air during the glacial periods, causing the formation of vast permafrost in this area.

With the advent of the late glacial stage, the Scandinavian Ice Sheet became extinct, leaving behind ice caps and glaciers in some limited areas. With the release of the immense weight of the ice sheets, the Scandinavian Peninsula began to rise. Parts of this peninsula are still slowly rising today at a rate of about 1cm per year. In modern times a number of ice sheets and glaciers remain in the Arctic Circle. These include the Greenland Ice Sheet and numerous smaller ice sheets in Canada’s Arctic Archipelago, Svalbard, Novaya Zemlya, Severnaya Zemlya and Iceland, as well as ice caps and alpine glaciers in Alaska, Canada and Scandinavia.



Ice sheet and continent during the last glacial period (Peltier,1998)

3. Natural Condition in the NSR

3.1.9 Permafrost

Earth and soil that remains frozen through an entire summer and two winters or longer is called permafrost. Permafrost is found in Siberia, interior China, Alaska and northern Canada and accounts for 14% of the earth's landmass. The world's deepest permafrost is found in the Yakutia of Siberia, which is frozen to a depth of almost 1,000m.

Permafrost may be classified as "continuous," meaning permafrost that extends unbroken both horizontally and vertically, or "discontinuous," which includes permafrost found in isolated patches. The map at right illustrates the distribution of these two types of permafrost. During the last glacial period, the continental shelf that was exposed above the surface of the ocean consisted of thick permafrost, which later sank beneath the ocean as the sea level rose. Because the water surrounding this shelf hovers around the freezing point of -1.5°C , and the water does not warm up much during the summer, this sunken permafrost (the "subsea permafrost" in the map) remains mostly frozen today. As the map shows, in the last glacial period the subsea permafrost extended across a remarkably broad area, encompassing the continental shelf from the Taymyr Peninsula to the Mackenzie River delta, which had not been covered by the Scandinavian and Laurentide ice sheets.

In contrast to this subsea permafrost, which was preserved at a uniform temperature, the continental permafrost was exposed to seasonal temperature variations of as much as 100°C in a given year. Melted water would pour into the cracks formed during the winter cold and freeze to create ice wedges. Each year these ice wedges grew gradually, so that today great wedges can be seen around the coast of the Arctic Ocean. These ice wedges are so thick that they create the illusion of soil wedges penetrating deep into a huge block of ice. In the Lena, Yana, Indigirka and Kolyma river basins of Siberia's Arctic coast, cliffs of ice are apparent. These cliffs, called edoma ("corroded land"), were formed when the ice in exposed sections of permafrost and ice wedges melted rapidly.

In terms of NSR, the presence of permafrost must be taken into careful consideration in the design of port facilities and peripheral approaches, construction of navigational support systems and the execution of dredging operations.

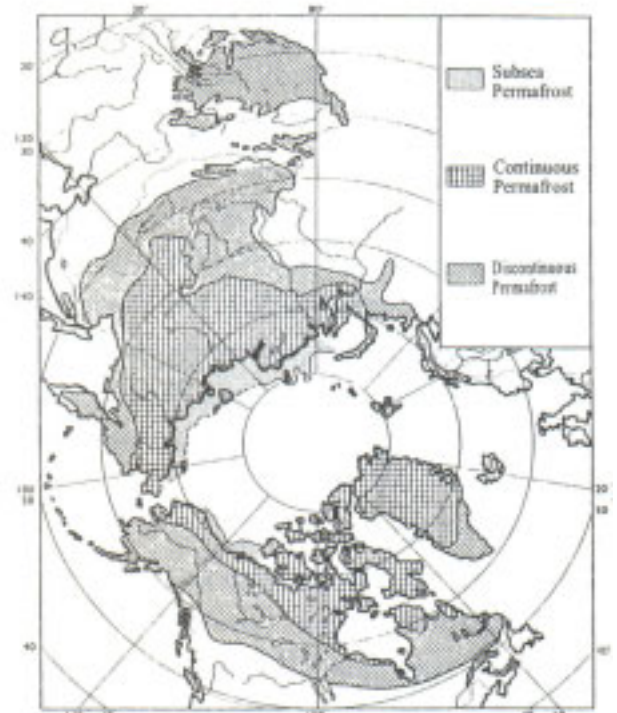

Distribution of permafrost (Kinoshita, 1988)

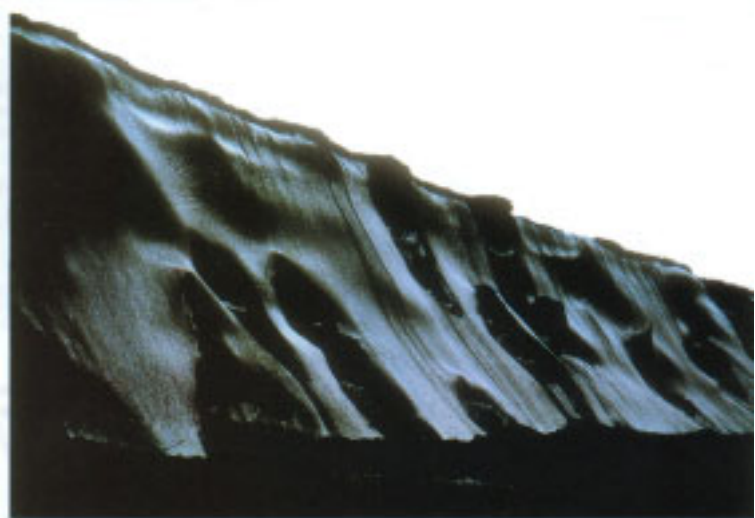

A glance of edoma (Photo:Fukuda)

3.1.10 Subarctic Coniferous Flora

The vast forests of the taiga sprawl across the subarctic landmass north of 60° N, where temperatures sink below -40°C and the days are almost completely dark during the winter. The word “taiga” comes from a Siberian indigenous word for “primeval (coniferous) forest,” and is today extended to mean all of the coniferous forests distributed throughout the subarctic regions of the northern hemisphere. Siberia’s taiga may be divided into two zones: the “light taiga,” consisting largely of annual conifers such as larch, and the “dark taiga” characterized by perennial conifers. The Siberian taiga covers a larger area than the entire tropical forest of the Amazon basin.

The surface of the permafrost melts in the summer but freezes again in the winter, for which reason it is referred to as the “active layer.” Below this active layer lies the hard, frozen permafrost. Water cannot permeate the permafrost, so water that melts in the active layer stays there.

The roots of the larch support quite large trees even though they reach no more than 20cm into the soil of the active layer. When the melting of the active layer reaches the boundary of the permafrost layer, the trees easily topple and are rooted up. As the muddy surface of fallen trees and soil absorbs more solar radiation, the land caves in to form a depressed pond that destroys the subarctic vegetation. When permafrost melts, it shrinks and subsides to form a plate-like depression called an alas.

Water then collects in the depression, alas, and freezes during the following winter. In the next summer, when the alas melts again, much more water collects in the alas. The alas gradually grows through this seasonal process.

Over the course of many years, alas formations extend to depths ranging from 3m to 20m and can cover an area of 0.5–100km². In areas covered with large volumes of ice, these bodies of water freeze in the winter and melt in the summer. The water that cannot penetrate deep into the soil collects in the ponds and lakes that dot the terrain over a wide area. These features can be seen around the North Slope of Alaska, which faces the Arctic Ocean. North of the subarctic forest, the active layer becomes thinner, and the woodland gives way to tundra where only the most stunted vegetation can grow.



Subsidence caused by the growth of an alas
(Photo: National Institute of Polar Research)



North Slope of Alaska
(Photo: National Institute of Polar Research)

3. Natural Condition in the NSR

3.1.11 Mineral Resources

Buried beneath the land north of 60° N is a magnificent cache of natural resources. The broad, rolling taiga and tundra and the adjacent continental shelf are rich in minerals such as gold, silver, copper, iron, zinc, tin, nickel and diamonds, as well as energy resources such as coal, petroleum and natural gas. Every sort of major natural resource is within easy grasp.

Iron and aluminum are found throughout the Scandinavian and Kola Peninsulas. The Yenisey basin is rich in copper, nickel, platinum and cobalt, while the Mirnyy area in the upper reaches of the Lena are home to large reserves of diamonds. The upper reaches of the Kolyma and the mountains of northwestern Canada produce gold and zinc respectively.

Rich coal deposits are known to be present on the North Slope of Alaska, in the Lena valley and from Dickson to the Taymyr Peninsula; mining is currently active on Spitsbergen and at the Vorkuta mine in the western Yamal Peninsula. Not shown in the illustration is a particularly large find of petroleum in the continental shelf of Canada's Arctic Archipelago. This deposit has been known for some 200 years but was ignored because of the insuperable difficulties of extracting petroleum under conditions of extreme cold, permafrost and sea ice. In 1968 an offshore oil field, believed to contain vast reserves, was discovered at Prudhoe Bay in Alaska. Development planning began immediately, with R&D in icebreaking tankers getting under way the following year, but the project was fraught with difficulties and the development consortium ultimately opted to construct a pipeline instead. To protect the environment in the permafrost area a suspended pipeline was completed, and shipments to the port of Valdez on the south coast of Alaska began almost 10 years after the start of the project in 1977. Meanwhile Canada, reeling from the competition from the Alaska pipeline and the oil crisis of the late 1970s, began exploring for oil and gas fields in the Canadian Beaufort Sea and the Arctic Archipelago, completing many successful test wells. Unfortunately the exploitation of this resource was deemed unlikely to turn a profit and a pipeline was abandoned at the design phase. Russia began producing oil in the Ob delta and the Pechora area in the 1970s, and today transports this oil to the country's central markets via pipeline.



Distribution of mineral resources in the Arctic (revision to the Atlas of the Polar Regions)

3.2 Characteristics of the Arctic Ocean

3.2.1 Rivers Flowing into the Arctic Ocean

Many rivers in the Eurasian and North American continents flow northward and empty into the Arctic Ocean. In descending order of annual flow, the four largest of these rivers are the Yenisey River, with the seventh largest annual flow in the world, and the Ob, Lena and Mackenzie Rivers. Although documented estimates vary widely, the total annual flow into the Arctic Ocean is thought to be in the neighborhood of 2,500–3,500km³. Because the surface water in the Arctic Ocean flows into the Atlantic Ocean on the Greenland Current, the Arctic Ocean is believed to form a vast reservoir of river water supplying the Atlantic Ocean. The annual water volume supplied from the Arctic Ocean to the Atlantic Ocean is the world’s second largest after that of the Amazon River.

These rivers are covered in thick ice in the winter. In the spring, the snow and ice upstream, which is further south, begins to melt, carrying the runoff downstream. This runoff collects and swells in the lower reaches, lifting and crushing the river ice and carrying it further downstream to the area where the ice is thickest, forming ice jams. Pent up by the ice jam, the water overflows its banks and changes course. These natural processes in the Arctic have left their traces everywhere across the vast tundra in the form of meandering rivers and unique semicircular lakes.



Annual flow of major rivers into the Arctic Ocean (Aagaard-Carmack,1998)

The volume of river flow into the Arctic Ocean is highest during the spring thaw, exhibiting dramatic seasonal changes. In June, when the monthly flow volume peaks, the runoff of the Yenisey and Lena Rivers reaches 80,000 metric tons of water a second, while the Ob discharges 30,000 metric tons and the Mackenzie 15,000 metric tons. In the winter, these rivers contract to a relative trickle of 5,000 metric tons of water per second—a mere fraction of their springtime height. Even at these seasonal lows, however, these great rivers are far larger than even Japan’s major rivers at their maximum flow volumes.



Ice jam (Photo: National Institute of Polar Research)

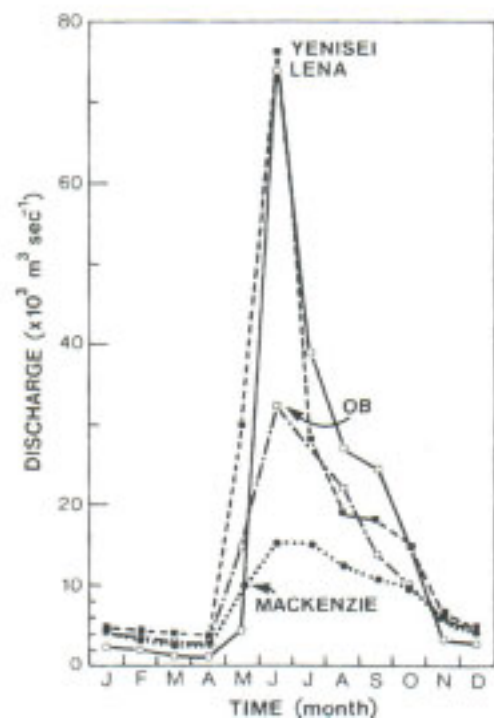

Seasonal variation in flow of the four largest Arctic rivers(Carmack, 1986)

3.2.2 Oceanic Structure and Deep Water Formation in the Arctic Ocean

Near the surface of the world's oceans, the water is directly affected by solar radiation, agitation by the wind, evaporation and precipitation. This surface layer, called the mixed layer, is thoroughly churned by the action of waves and convection currents. Below the mixed layer, where temperature and salinity are fairly uniform, the thermocline and halocline are observed, where the temperature and salinity change abruptly. In most oceans, the thermocline and halocline occur at almost the same depth. During the summer, forced convection by the wind restricts the mixed layer to a relatively shallow depth of 10-20m, but in the winter, natural convection causes the mixed layer to extend up to 200m deep or more.

The occurrence of sea ice is closely connected with the underlying oceanic structure. The temperature of maximum density of seawater is below the freezing temperature; thus, in a homogenous ocean the entire water column would have to be cooled down to its freezing temperature before ice could form on the surface. In fact, winter convection is limited by the polar haloclines discussed above.

A unique feature of the structure of the Arctic Ocean is that the thermocline and the halocline exist at different depths. The mixed layer at the freezing point includes both a low-salinity surface layer and a halocline whose salinity increases with depth. This ocean structure is supported by a cycle in which a low-salinity water mass spreads over the continental shelf as an enormous volume of fresh water is supplied from the arctic rivers, and brine of high salinity is released in the winter freezing process; when the ice melts in the summer, a huge volume of fresh water is supplied again to the seawater. Only the Arctic Ocean exhibits this structure.

A warm, high-salinity current (with a temperature of 3–4°C and salinity of 3.5%) called the Spitsbergen Current flows through the Fram Straits from the North Atlantic Ocean into the Arctic Ocean and sinks below the halocline to an intermediate layer. At the same time, the Arctic Ocean's surface low-salinity water (temperature –1.5–+2°C, salinity 3.1%) flows out into the North Atlantic in the form of the East Greenland Current. The volume of this flow is estimated to reach approximately 3.5 million metric tons of water per second. On the Pacific side, about 300,000 metric tons per second flows into the Arctic Ocean through the Bering Strait. An annual average of 100,000 metric tons of lighter water is estimated to flow into the Arctic Ocean from coastal rivers, but seasonal variations are immense.

The water from the North Atlantic Ocean that flows underneath the halocline transfers heat to the low-temperature, low-salinity water on top, causing the incoming flow to become still heavier and sink, forming a low-temperature, high-salinity

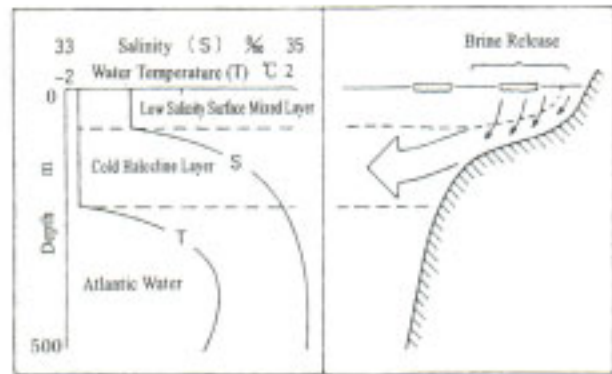

Vertical distributions of water temperature and salinity and formation of halocline in the Arctic Ocean (Carmack,1986)

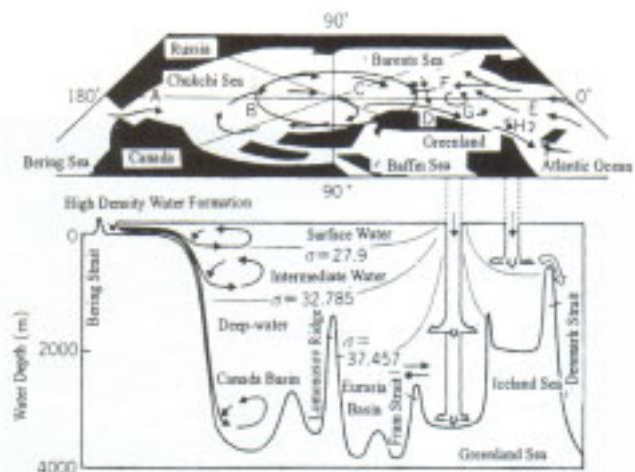

Structure of the Arctic Ocean and deep-water formation (Aagaard,1985)

water in the Arctic Ocean. In the Greenland and Iceland Seas, the low-pressure system that sits over Iceland in the winter draws deep water up to the surface, creating a convection current. This action cools the deeper parts of the ocean to form a low-temperature, high-salinity water. The deep water of the Greenland and Iceland Seas form a North Atlantic deep water that extends past the Straits of Denmark. The entire cycle encompassing all of the world's oceans takes 2,000 years to complete one full cycle of water supply through deep-water circulation.

3.2.3 Sea Ice

The ice that floats on the ocean's surface is known by the generic name of "floating ice." Floating ice includes ice from frozen seawater, ice that flowed into the ocean from rivers and tides, icebergs from glaciers and ice islands that break off of various ice shelves. The number of icebergs and ice islands is much smaller in the Arctic Ocean than in the Antarctic Ocean.

Terminology and classification of sea ice is given in the appendices at the back of this book. Initial ice formation occurs at or near the surface of the seawater in the form of small platelets and needles called frazil. Continued freezing results in the production of grease ice, a soupy mixture of seawater and unconsolidated frazil crystals. Under quiescent conditions the frazil crystals rapidly freeze together to form a solid, continuous ice cover with thickness between 1 and 10cm. Wind-induced turbulence in the water, however, often inhibits immediate development of a solid cover. In the presence of a sustained wave field, circular masses of semiconsolidated frazil called pancakes form, ranging from 0.3 to 3.0m in diameter. Eventually these pancakes freeze together to form a continuous sheet of ice, called first-year ice, thicker than 30cm. The thickness of sea ice during its formation is known to be roughly proportional to the square root of the cold sum; also called the accumulated freezing index, this value is a summation of the absolute value for average daily air temperature below the freezing temperature. When first-year ice survives one summer it is called second-year ice, and if it lasts for two summers or more it is called multi-year ice. Multi-year ice varies greatly in thickness according to the degree of annual melting and accumulation, but is usually 3–6m thick.

Sea ice contains salt. Although the salt is not trapped in the crystal lattice of the ice when it freezes, water with concentrated salinity (brine) is trapped between the ice plates. Every kilogram of sea water contains roughly 35g of salt, 3.5%." The salinity of sea ice is defined as the salinity of the fully melted sea ice. Immediately after formation, sea ice has a salinity of about 1%, which indicates that one-third of the brine is trapped in sea ice during the freezing process, while two-thirds is returned to the ocean. With the passage of time, the salt in the sea ice drains out, yielding a salinity of 0.4–0.5% in 1m-thick one-year ice, almost no salinity in the surface layer of multi-year ice and a decreased salinity of 0.2–0.3% in the lower layer of multi-year ice. The brine in sea ice maintains an equilibrium concentration value with respect to temperature: As temperature decreases, ice crystals separate from the sea water; as temperature increases, the ice melts to dilute the brine. Changes with time in the structure of sea ice occur mainly in

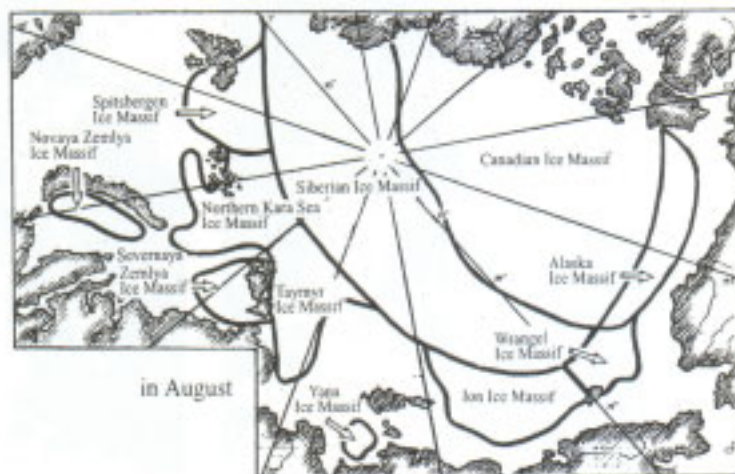

Ice massifs in the Arctic Ocean (Romanov,1994)

3. Natural Condition in the NSR

response to temperature changes in the ice. Brine inclusions are particularly sensitive in this regard; even small changes in thermal conditions can cause significant changes in the size, shape and distribution patterns of the inclusions and concentration of the entrapped brine. Because the strength of sea ice depends on its brine component, when air temperatures rise in spring the sea ice quickly becomes brittle.

An expanse of ice floe less than 10km in diameter is called an ice patch, and an expanse of ice floe more than 10km is called an ice field. Ice fields are further classified as small, medium and large ice fields. Very large compact ice fields, having an area of 1,000km² or more and ice concentration of 70% or more, are referred to as ice massifs.

Ice massifs composed of multi-year ice in the Arctic Ocean are called Arctic ice massifs. Arctic ice massifs are further divided into Canadian and Siberian ice massifs, and other ice massifs extending into peripheral areas such as Spitsbergen, the Kara Sea, the Taymyr peninsula, Ion and Wrangel Island are named accordingly. In coastal regions as well, areas of relatively stable ice massifs have been found; these are named for their respective regions, Novaya Zemlya, Severnaya Zemlya and Yana.

3.2.4 The Extent of Sea Ice in the Northern Hemisphere

Beginning in 1973, satellite-borne microwave radiometry came to be adopted for year-round, all-weather and day-and-night surveillance of the ice cover in the Arctic. The monthly average distribution of sea ice in the northern hemisphere during March, the month of maximum extent, and September, the month of minimum extent, for 1986 is illustrated below as an example. Areas of open water are indicated in light blue, while areas where the sea ice is so concentrated that no water can be seen are colored a purplish dark red. The color scale between these two extremes is indicated accordingly.

In winter (March), the region of sea ice extends throughout the Arctic Ocean as far as Hudson Bay, Baffin Bay, the Sea of Labrador, the Greenland Sea, the Baltic Sea, the Sea of Okhotsk and the Bering Sea, except for some regions of the Barents Sea. Because the line of 66.5° N runs close to the north shore of Iceland, the eastern Greenland Sea, northern Sea of Norway and southern Barents Sea comprise a vast region free from sea ice even

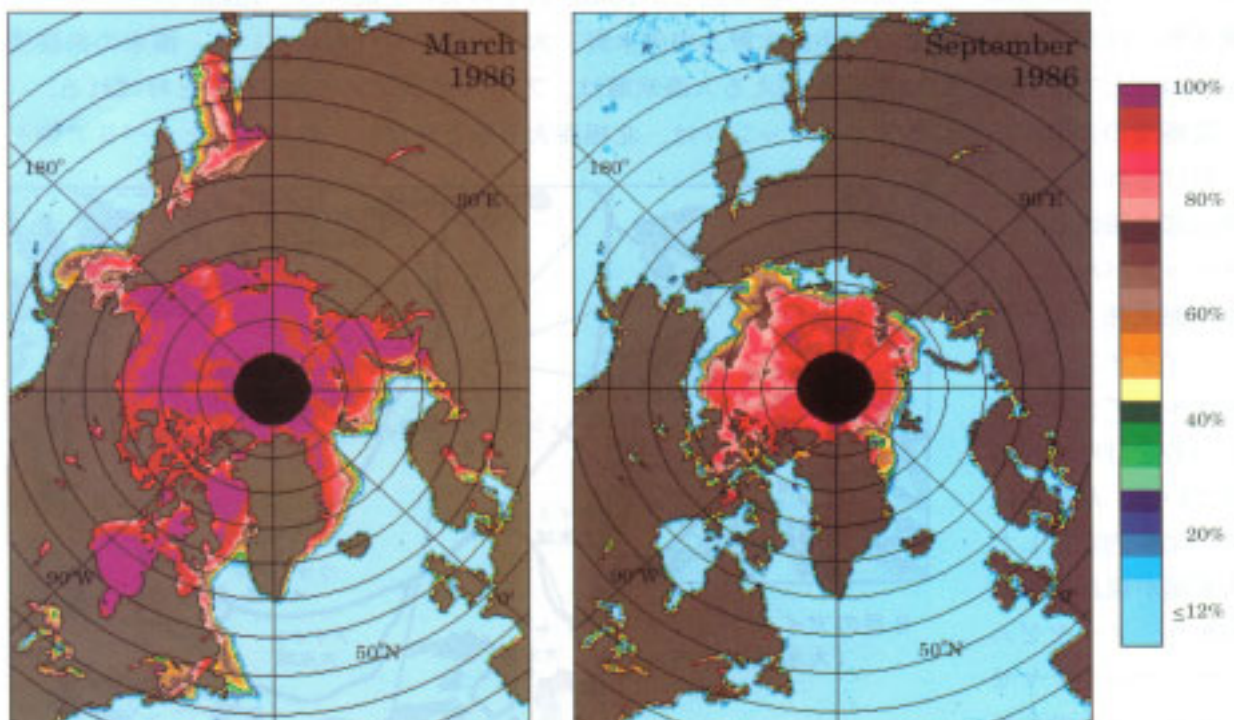

Monthly average distribution of areas of sea ice, March and September 1986.

in the long Arctic nights. Though the Arctic Ocean and Hudson Bay are covered in sea ice almost every winter, other peripheral seas vary widely in the extent of sea ice from year to year.

At the end of summer (September), only the multi-year ice at the very center of the Arctic Ocean remains unmelted. This region of multi-year ice is composed of several ice massifs, whose extent and locations vary widely from year to year. In some years the area of sea ice draws closer to the Siberian coast, at others to the Canadian or Alaskan coast. Operations to maintain the safety of the NSR require monitoring and assessment of these trends. In the example illustrated in the image below (September 1986), we can see that multi-year ice reached both coasts of Severnaya Zemlya and Wrangel Island, and an ice massif with higher concentration appeared off the coast of Novaya Zemlya.

3.2.5 Ocean Currents and Ice Drifts in the Arctic Ocean

Although few wide-area observations of ocean currents in the Arctic Ocean are currently available, it is clear that the surface layer and intermediate layer behave in different ways.

Two main currents exchange water between the Arctic Ocean and the world's other oceans through the Fram Strait. The West Spitsbergen Current is a northward-flowing extension of the Norwegian-Atlantic current, which is itself a branch of the Gulf Stream. As it reaches the Arctic Ocean this current sinks below the Arctic surface water to transform into the intermediate water layer, flowing along the Eurasian continental shelf into the inside of the Arctic Ocean. At the center of the ocean this current winds around to the north coast of Canada and flows in the same direction as the surface current of the Arctic Ocean.

One of the prominent surface currents in the Arctic Ocean is a low-velocity current rotating clockwise around the mid-point between the north coast of Alaska and the North Pole. The outer flow of the current has higher velocity and more constant direction than the inner flow has. The direction of the inner flow is less stable. The sea ice drifts on these currents, which are collectively known as the Beaufort Gyre. On the Siberian side, the Beaufort Gyre flows from the Bering Strait to the Fram Strait. Nansen's Fram and most of the vessels that were firmly beset in the polar ice drifted on this gyrating current.

On the Siberian continental shelf a current

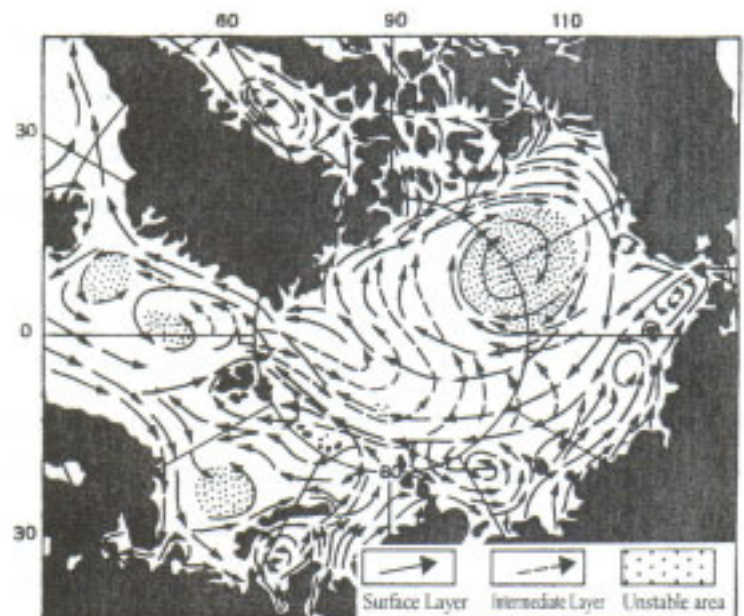

Arctic ocean currents of surface and intermediate layers

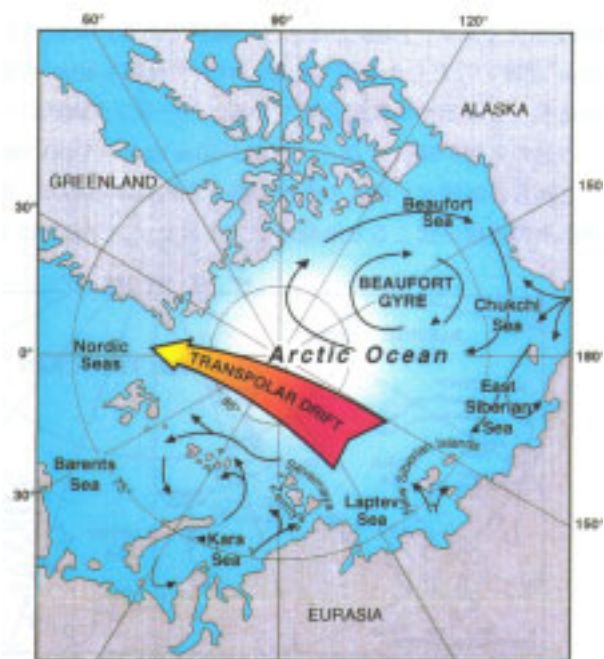

Ice drift pattern in the Arctic Ocean
(Kassens, 1998)

3. Natural Condition in the NSR

flows from west to east. Because a chain of islands exists between this current and the current flowing toward the Fram strait off the continental shelf, a complex, vortex-like flow pattern is generated in this area. The movement of sea ice in the center of the Arctic Ocean, which is unaffected by the coasts, are significantly affected by the long-term predominant winds, which generally follow the high-pressure contour line. The speed of its movement is 5% of the wind speed above the sea surface: if the wind blows at 10m/s, the sea ice drifts at about 0.5m/s, or one knot.

3.3 Natural Conditions in the NSR

3.3.1 Geographical Environment

Broadly speaking, the NSR rounds the northern coast of the Scandinavian Peninsula, then passes in succession through the Barents Sea, Kara Sea, Laptev Sea, East Siberian Sea and Chukchi Sea to reach the Bering Strait. These seas are divided by groups of islands on the continental shelf: Novaya Zemlya, Severnaya Zemlya, the Novosibirskye Islands and Wrangel Island. Between these islands, or between the islands and the mainland, are a series of straits. A list of the major straits through which NSR ships must pass includes the Yugorskiy Shar Strait, which is located on the south coast of Vaygach Island and forms the southernmost entrance from the Barents Sea to the Kara sea; the Kara Gate Strait, the main shipping strait between the Barents and Kara seas; Vilkitskiy Strait, which separates Severnaya Zemlya from the northernmost extremity of the Eurasian continent, Cape Chelyuskin; Shokalskiy Strait, locating in Severnaya Zemlya north of the Vilkitskiy Strait; Dmitriy Laptev Strait, which is the southernmost passage between the Novosibirskye Islands and the mainland, linking the Laptev and East Siberian seas; Sannikov Strait, the second east-west passageway through the Novosibirskye Islands linking the Laptev and East Siberian seas; Long Strait, and which separates Wrangel Island from the mainland, linking the East Siberian and Chukchi seas. Most of these straits are notoriously perilous due to the heavy accumulation of deadly sea ice.

Because the entire length of the NSR lies over the continental shelf of Eurasia, the route comprises a large number of shallow zones. Although the western Barents Sea is more than 200m deep, the eastern Barents Sea is about 100m deep and the Kara Gate Strait is a mere 30m deep. The Kara Sea has numerous extremely shallow areas that are less than 100m deep, with numerous variations in depth, and some are as shallow as a few meters to 20m. In the Laptev Sea, which has the narrowest continental shelf in the Arctic Ocean, the NSR lies in deep seas, portions of which are over 1,000m deep. As one draws near to the Novosibirskye Islands, however, the sea

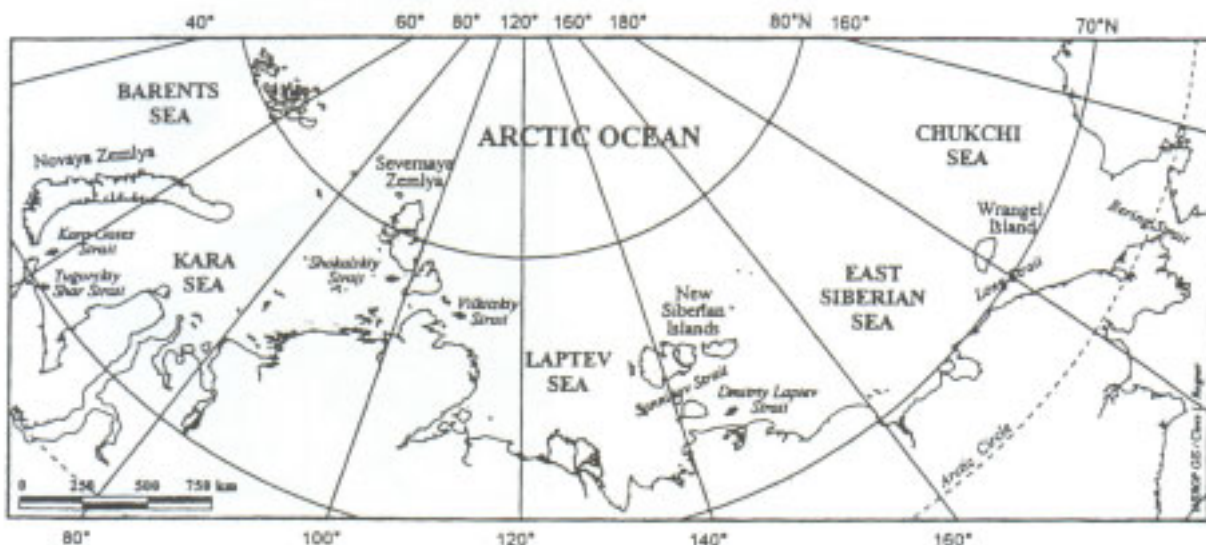

The seas and straits of the NSR (WP-167)

becomes shallower than 20m, and both the Dmitry Laptev Strait and the Sannikov Strait are roughly 20m deep; these areas are the shallowest parts of the NSR. The East Siberian Sea is less than 20m deep in the western part and around 40m deep in the eastern reaches, as is the Long Strait. The center of the Chukchi Sea is only 50m deep, with gentle variation in depth. The Bering Strait is home to two islands, Big Diomedede (Ratmanov) and Little Diomedede Islands; the seas around these islands are 60m deep to the east and 50m deep to the west.

These straits constrain the movement of seawater and sea ice. The tides that overlies the ocean currents move about dramatically. The accumulation of multi-year ice often causes the formation of local ice massifs.

3.3.2 Low-salinity Water

The NSR coast is nourished by freshwater from the rivers that flow into the Arctic Ocean from the Eurasian continent. As a result, the coastal seas such as the Kara Sea, which is fed by the Ob and Yenisey Rivers; the Laptev Sea, which is fed by the Lena; and the East Siberian Sea, into which the Indigirka and Kolyma rivers flow, form a broad coastal region of low-salinity sea.

The density of seawater is dependent on its temperature and salinity. Salinity is measured in weight per mil, meaning weight of salt in grams for every kilogram of seawater. Fresh water, which has a salinity of 0‰, reaches its maximum density at 4°C; at 0°C, it freezes. As salinity increases, both the temperature of maximum density (T_{pmax}) and the freezing point (T_f) decrease. However, the temperature of maximum density drops faster, so that the two intersect at a salinity of 2.47‰. As the fresh water in lakes and rivers cools during the autumn and winter months, the cooled water grows heavy and sinks, creating convection currents. At 4°C and lower, however, the water is too light to sink, forming layers without convection, so that only the lake surface is cooled and freezes over. Since seawater has a salinity of 3.3–3.5‰,

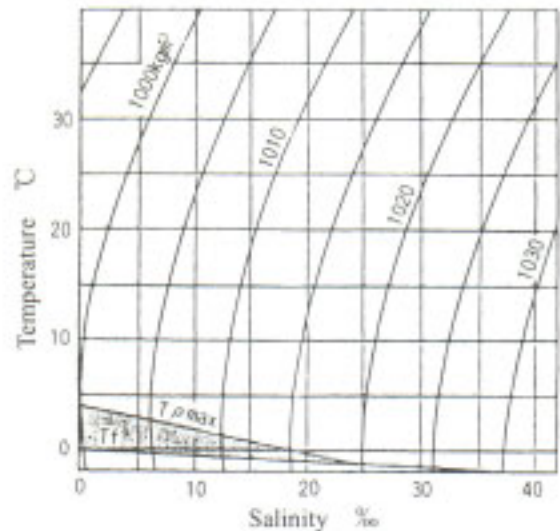

Temperature-density-salinity diagram of sea water (Ono, 1996)



Distribution of low-salinity seawater in the NSR (2.5‰ or less. Thick lines: winter; thin lines: summer) (Ono, 1996)

3. Natural Condition in the NSR

convection continues until the freezing point is reached. Water at salinity lower than 24.7% has a point of maximum density higher than its freezing point and therefore freezes in the same way as freshwater lakes. This action causes layers to form just before the freezing point is reached, preventing mixing from convection. When such low-salinity water cools rapidly, therefore, sea ice can build up rapidly. To ensure safe navigation of the NSR, it is important to keep in mind the presence of these low-salinity water masses.

A map of areas of the Arctic Ocean with surface salinity of 2.5% or less is provided below. As the map indicates, large swaths of the Kara, Laptev and East Siberian Seas consist of such low-salinity water. Areas shaded with light diagonal lines have 2.5% or lower salinity in the summer, and areas shaded with thick diagonal lines have 25% or lower salinity in the winter. It should be noted that the pattern of freezing in vast areas of the NSR is similar to that of freshwater lakes, a phenomenon seen nowhere else in the world's seas except the Baltic Sea, and that ice in the beginning stages of freezing exhibits properties similar to those of freshwater ice.

3.3.3 Sea Ice

The NSR is completely covered in ice for roughly six months of each year, from November to April, with the exception of some parts of the Barents Sea. Near the coastline is the “fast ice” (ice that is attached to the coastline), consisting of a mixture of one-year ice and multi-year ice. Beyond the fast ice is the much larger zone of drifting ice.

The summer lasts from June to September. During this time the sea ice melts rapidly, and both the extent and the strength of the ice cover decreases dramatically. The ice massifs, which appear every year in roughly the same locations, are mixtures of multi-year ice in the center of the Arctic Ocean and the accumulated remnants of the fast ice, which include many thickly rafting ice and ridges.

Using the satellite images taken with a microwave radiometer as described in 3.2.4, year-on-year changes in the status of sea ice extent in the summertime along the NSR area are shown in the diagram below. Based on satellite images taken in July and October of each year from 1979 to 1986, the presence/absence of sea ice was examined for each of several segments, 10° of latitude apart. In each year and month, areas where sea ice is present are enclosed in squares. Those with high concentration (70% or more) are indicated with dense hatching, and those with low concentration (less than 70%) are indicated with sparse hatching. In this diagram it is apparent that, except for 1979, in August and September, almost no sea ice was present in the Laptev Sea and the western part of the East

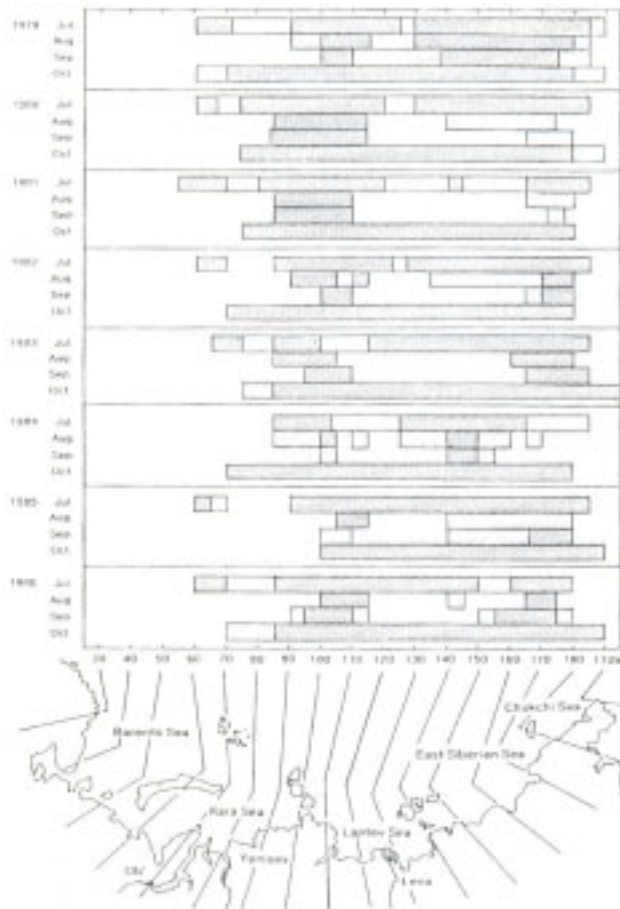

Sea ice concentrations in summer in the NSR regions (Ono,1996)

Siberian Sea. High concentration sea ice exists even during the summer in both sides of Vilkitskiy Strait, the Long Strait and its west side. Both of these two areas receive multi-year ice from the Arctic Ice Massif sustaining local ice massifs.

Another threat for NSR navigation is the ice massifs such as the Severnaya Zemlya, Taymyr, Ion and Wrangel Ice Massifs.

The following section provides an overview of sea ice conditions in each sea area.

In the Kara Sea, freezing begins in September in the northern reaches of the sea and extends to the southern part in October. From October to May virtually the entire sea is covered with ice in various phases of growth. Along the coast a non-uniform fast ice forms, and beyond the grounded ice the flaw polynya can be seen, such as the Ob/Yenisey Polynya in the southern Kara Sea. Flaw polynya, which include open water and thin ice areas, are generally observed between the fast and drifting ice. From June to September sea ice is rare in the Kara Sea, but thick ice is scattered around the western part of the sea. In the east, the Severnaya Zemlya Ice Massif, consisting of thick first-year ice of high concentration, presses in on the NSR. The Vilkitskiy Strait between the Taymyr Peninsula and Severnaya Zemlya is among the most treacherous for the NSR, as it is wracked by violent ice movement. The sea ice decreases to the minimum extent in mid-September, and is completely absent south of 75 ° N. In particularly hot summers the Kara sea is free of sea ice as far north as 80° N.

The Laptev Sea is the sea whose fast ice extends farthest into the Arctic Ocean, from January to June. With the average temperature dropping below -30°C in mid-winter, the fast ice reaches a thickness of 2m, and as much as 2.5m in the coldest winters. In the summer, the sea ice drifts southward in the western part of the Laptev Sea to collect in the gap between the Taymyr Peninsula and Severnaya Zemlya. In terms of navigation of the NSR, the Vilkitskiy Strait and the area off the coast of the Taymyr Peninsula may remain difficult to pass through even in the summer.

The East Siberian Sea is characterized by the shallowest continental shelf in the NSR. This shallow continental shelf keeps the fast ice highly stable; it extends 500km out to sea with thickness of 170–200cm. In the summer the prevailing winds blow from the south and carry drifting ice into the sea, creating a region of thin sea ice and flaw polynya that is easy to navigate. The East Siberian Sea has the largest presence of multi-year ice in the NSR, with multi-year ice accounting for 60% of the ice cover on the Ion Ice Massif and growing to thickness of 2.5m. In the summer the winds shift to arise from the north, supplying sea ice from the north to support the Ion Ice Massif. Freezing begins in September, and by mid-October the sea is entirely frozen over.



View of an ice massif in the Arctic Ocean (Photo: Nobuo Ono)

3. Natural Condition in the NSR

The Chukchi Sea is completely covered in ice from mid-December to mid-May. The condition of the ice in this sea changes rapidly, with 80% of the winter ice disappearing in the summer. Factors contributing to this rapid change are temperature, winds, ocean currents and morphological effect of the Wrangel Island and the ocean floor. The multi-year ice carried in from the north is seen in Long Strait, which separates the Wrangel Island from the Siberian mainland. These factors will have a strong impact on the selection of an optimum route for the NSR.

3.3.4 Precipitation and Snow Cover

The snow cover on sea ice is a major controlling factor in its growth and melting, and significantly affects the propulsion and steering performance of icebreaking vessels. Most of the Arctic Ocean lies under weak high-pressure system throughout the year. Except for the occasional effect of the Iceland low-pressure, which encompasses the Barents Sea and at times the Kara Sea, storms are quite rare. As the table of monthly average precipitation shows below, precipitation in all regions is highest in the summer—though even then, no more than 40mm—and annual precipitation is a rather low 180–250mm a year.

The depth of snow cover on level ice varies widely from place to place. An overview of the snow cover in the Arctic Ocean is as follows: On the continental shelf of the NSR, particularly on the relatively flat first-year ice, areas of snow cover with 5-10cm are twice as common as those with only 0–5cm. In the Alaskan and Canadian Arctic, on the other hand,

areas of snow cover with 0–5cm are slightly more common than those with 5–10cm. A histogram calculated from observation data of depth of snow cover on multi-year ice from over 100 locations shows that the most common range of snow depth is 12–18cm on flat sea ice but as much as 60–100cm on pressure ridges. This is because blowing snow tends to pile up around pressure ridges. In April, when snow cover on the ridges is at its peak, snow cover of 200cm is found in Greenland and 140cm in the NSR region.

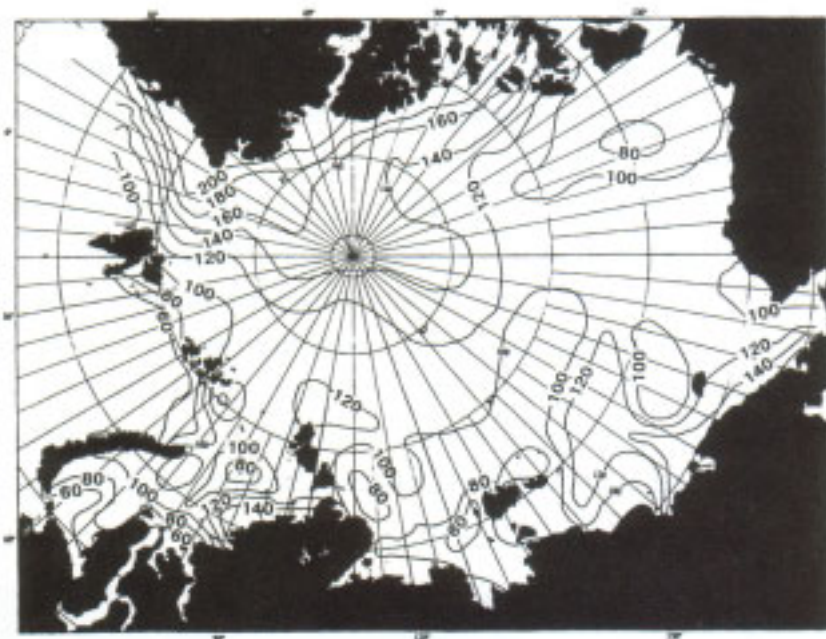

Maximum snow cover in the vicinity of pressure ridges in April (cm)

Average monthly precipitation in each region of the Arctic Ocean (mm) (Radionov, 1997)

Location	Month												Year
	Jan.	Feb.	Mar.	Apr.	May	Jun.	Jul.	Aug.	Sep.	Oct.	Nov.	Dec.	
Arctic Basin	11	8	7	7	11	15	24	25	23	17	11	10	179
Rudol'fa Island	17	17	17	16	16	20	28	32	30	24	20	17	254
Zhokhov Island	13	8	8	9	14	21	39	33	22	16	13	10	206
Wrangel Island	16	10	10	8	13	15	34	35	32	24	17	15	229

3.3.5 Puddles

The brine in sea ice works to keep salinity in equilibrium with temperature. Therefore, when the temperature of sea ice changes, its salinity moves to the equilibrium level, by separating or thawing ice crystals in the sea ice. When rising summer temperatures bring sea ice close to the melting point, even if the air temperature is below the freezing point, the brine volume of the sea ice increases and nearly a half of the weight of the sea ice comes to consist of brine. This marked increase in brine volume rapidly weakens the sea ice.

The brine above the water surface collects in a depression on the sea ice surface, forming pools called puddles. The puddles absorb solar radiation and thaw the ice that surrounds them, growing larger and deeper. When the air temperature temporarily drops, however, the puddle becomes covered with a thin lid of ice; given a sufficiently strong wind, even when the temperature stays around the freezing point the lid is preserved due to latent heat of evaporation. The water inside the puddle covered by the lid absorbs solar radiation, which often keeps it higher than the freezing point. Because the salinity of the water in the puddles is lower than the water in the sea below it, even if the thawing process thins the puddle bottom and produces a hole in it, the puddle water's lower density will prevent it from leaking down into the sea. On multi-year ice, puddle water serves to wash out brine, forming a layer of surface ice with almost zero salinity. In fact, in summertime the water from puddles on multi-year ice is often used as drinking water.

Puddle formation is deeply affected by the snow cover, beginning in the fast ice at lower latitudes and gradually proceeding northward to the center of the Arctic Ocean. On the NSR coast, puddles begin to form in late May; puddle formation in the center of the Arctic Ocean starts one month later, in late June. The appearance of puddles heralds the arrival of the brief Arctic summer. The sea ice gains a huge thermal inertia due to the latent heat in the thawing process of ice, stabilizing the temperature in ice-covered waters.

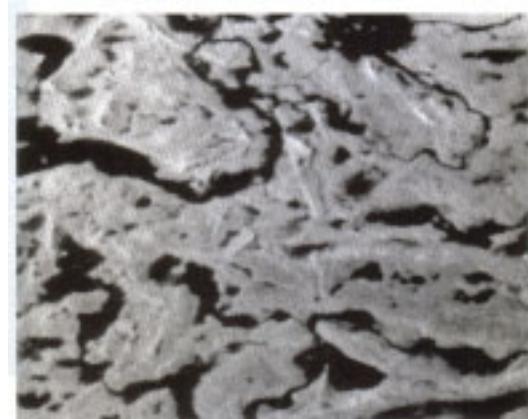

Puddles (Fetteerer: Untersteiner,1998)

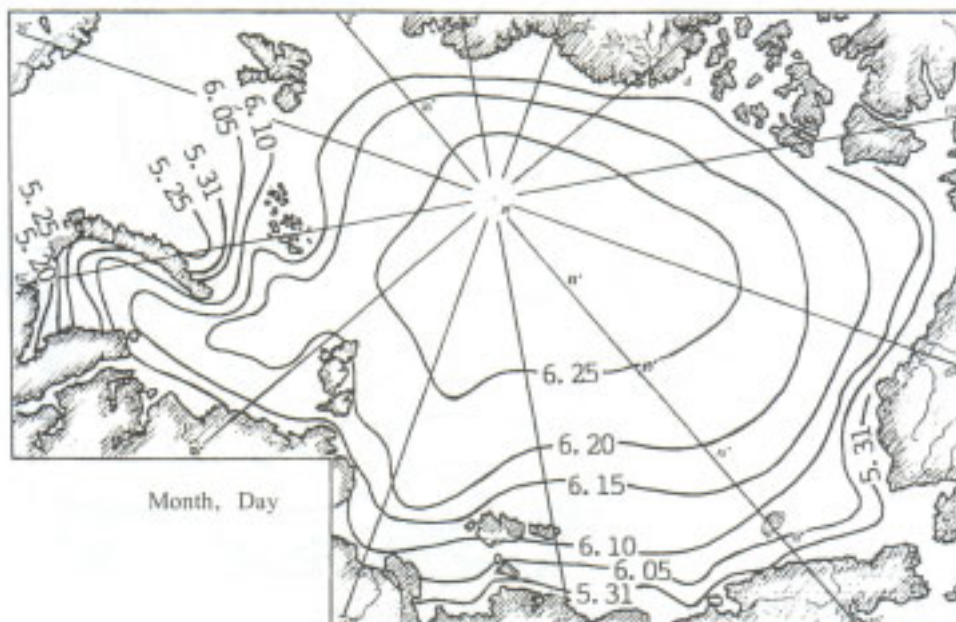

Average date of formation of puddles (Romanov, 1994)

3. Natural Condition in the NSR

3.3.6 Pressure ridges

The ice that covers the Arctic Ocean ranges in thickness from 1–2m for first-year ice to 3–4m for multi-year ice. Relative to the area it covers, then, the sea ice is extremely thin. The sea ice drifts and is carried by ocean currents, tides and wind. The shearing forces create cracks and fractures in the sea ice, causing open water to appear. These fractures can grow larger, opening up leads, but the fractures can also close up in a short time. These leads are often covered by a thin layer of ice, but when they close up the thin ice layer is crushed and rafted, finally piling up on the old ice. This heavy piled-up ice creates new fractures parallel to the original fractures, but these new fractures soon follow a similar crushing and piling-up process. Finally a range of piled-up ice is formed along the first fracture; this formation is called a pressure ridge. The underwater portion of the pressure ridge is called a keel, and the surface portion is called the sail. The average sail height of pressure ridges in multi-year ice is 2–3m, but sometimes they can tower as high as 8m or more.

In multi-year ice, the ratio of the sail height of pressure ridges to the ice thickness ranges from 0.9 to 1.5. Although the sea ice is very thick and the sails of pressure ridges are relatively low in the ice massifs in the center of the Arctic Ocean, at the margins of the southwest Kara Sea and the Chukchi Sea the sails of ice ridges are often higher than the thickness of the sea ice. When the distribution of the height of pressure ridges on multi-year ice in the Arctic Ocean is plotted as shown below, pressure ridges on the Canadian coast are relatively high at 3m, while those of the NSR are relatively low at 1–1.5m.



Leads and ridges in the region covered by first-year ice

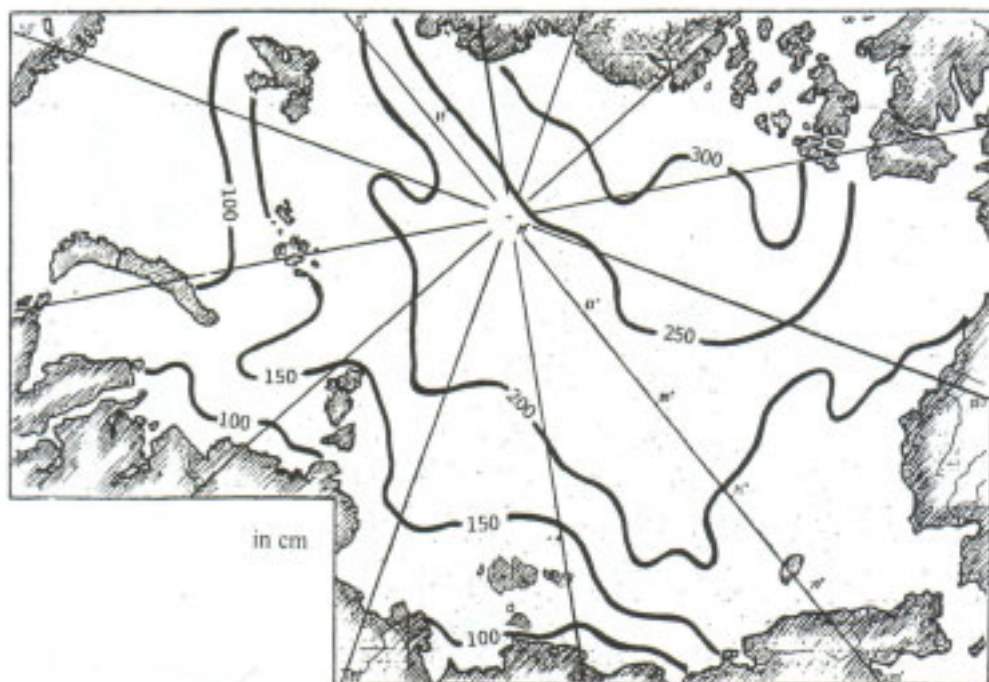

Average sail height of pressure ridges on multi-year ice (Romanov, 1994)

3.3.7 Ocean Currents and Tides

Ocean currents in the shallow continental shelf of the NSR, though governed by local geographical features, in general flow from west to east. In the narrow straits between islands the action of the tides becomes ferocious, as seafarers in the age of explorers frequently discovered.

Some of the fastest tidal flows are observed at Yugorskiy Shar Strait on the south coast of Vaygach Island, which lies between the Eurasian continent and Novaya Zemlya. When the northeast wind is strong, boosting the tidal force with wind power, the tides can reach a top speed of 6.9 knots. Close to the Vilkitskiy Strait south of Severnaya Zemlya, tides are clocked at about 5 knots; speeds of 3–4 knots are seen in the Dmitri Laptev Sea to the south of the Novosibirskiye Islands. Records of early voyages reveal that small ships were unable to pass through these treacherous straits, and had to wait until the tide turned.

Each tidal cycle is completed in half a day (12 hours). At ports constructed near the mouths of major rivers or in areas unaffected by current, the coastal geography factors strongly in the variation between high and low tide. In seasons when the river flow is high, large tidal effects can be expected. The design, construction and utilization of port and its facilities in the NSR should take these effects into account.

A detailed analysis of the tidal effects revealed that tidal effects were stronger along the NSR coast than in the center of the Arctic Ocean, by about 2 knots. With ocean currents, tides and winds amplifying each other and canceling each other out, fluctuations in direction and speed of flow are drastic, particularly in narrow straits.

GUIDE TO NAVIGATION THROUGH THE NORTHERN SEA ROUTE (No.4151B)

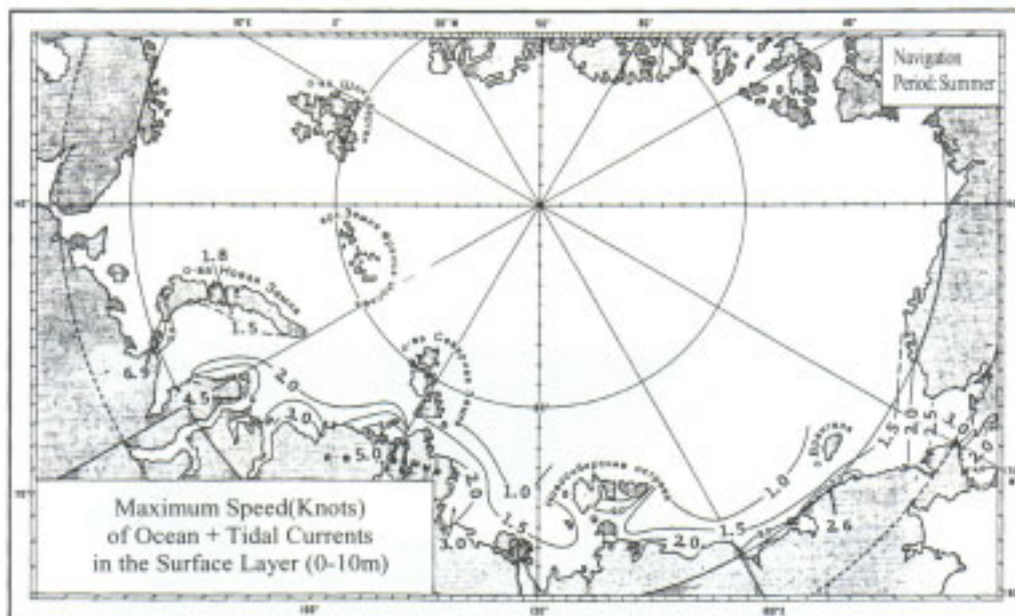

Distribution of maximum current speeds in the NSR (Administration of the NSR, 1996)

3.3.8 Marine Life

Moving northward to the Arctic coast, the flora and fauna of the taiga give way to forms of life that are better adapted to the harsher natural environment of the taiga. Unforgiving as the conditions in this realm may be, the vast continental shelf of the NSR is teeming with a stupendous variety of marine life. When the sun appears on the horizon to end the long Arctic night, phytoplankton, the base of the Arctic food chain, begin to bloom. This awakening triggers activity throughout the food chain from zooplankton up to fish, birds and marine mammals, from the first days of spring till the late-summer onset of the Arctic night. In the NSR seas, polar bear, walrus, seal and whale famously occupy the apex of the food chain.

3. Natural Condition in the NSR

Data on marine life in the NSR indicate substantial variance according to the area investigated, and from season to season and year to year. Moreover, the distribution of habitats, breeding patterns and characteristics of the flora and fauna in this region remains poorly understood; many questions will simply have to wait for further survey efforts. For the present purposes, we will select three species of mammal and provide an overview of the distribution of their habitats.

The polar bear population is estimated at 20,000–30,000, and their active range is confined to a small area. Living close to the ice fields, their movement mirrors the seasonal expansion and contraction of the Arctic ice. When the ice melts, polar bears live on the nearby coasts. In the NSR region, many polar bears can be seen in March throughout a wide swath of territory from Novaya Zemlya through the Kara Sea coast, the east coast of Severnaya Zemlya and the north shores of the Novosibirskiye Islands to Wrangel Island and the Chukchi Sea. In August they are concentrated in Severnaya Zemlya and Wrangel Island.

About 250,000 walrus are estimated to exist, living mostly in a band from the Chukchi Sea to the Bering Sea. In the NSR region, some 5,000 inhabit the Laptev Sea and near the north coast of the Novosibirskiye Islands.

Estimates of the worldwide seal population run into the millions, though their number in the Arctic is not known with certainty. Seals, generally found in the entire NSR region, tend to cluster near the coast during the summer and move to the rim of fast ice during the winter. When the seas are covered in ice, the seals breathe through crevices, leads and fractures; they are also known to maintain their own breathing holes even in the growing sea ice. With one breath a seal can typically stay underwater for seven to eight minutes, and sometimes as long as 20 minutes. If the Arctic Ocean were ever polluted by an oil spill, the seal population would be among the most seriously affected of all Arctic fauna.

Many gaps in knowledge and points of controversy remain regarding surveys and data on the Arctic ecosystem and its food chain from phytoplankton to the mammals at its apex. More detailed studies and forecasts are needed at this point for use in reliable environmental impact assessment on the implementation of NSR shipping.

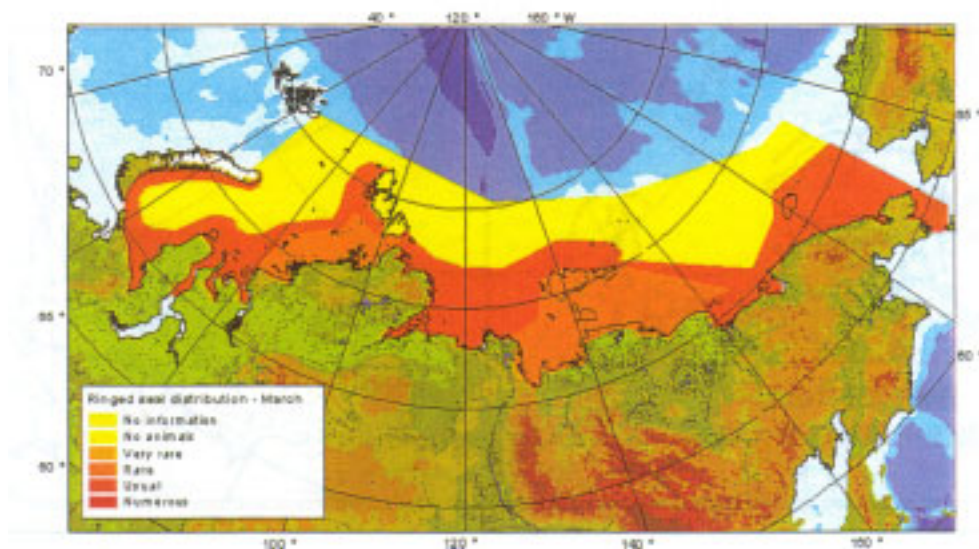

Distribution of seal habitats (March) (WP-99)

4. Technological Aspects of NSR Navigation

4.1 Ice-transiting Ships

The most salient characteristic of the NSR is the presence of sea ice. Not only is this sea ice a significant barrier to the feasibility of ship operations, reducing their speed, it is a hazard as well, which can at times cause damage to their hulls and propulsion systems. Navigation of these unique waters requires the design and construction of special vessels, generically referred to as ice-transiting ships. These ships are classified as ice-worthy/ice-strengthened ships, icebreaking ships and/or icebreakers, depending on their tasks and icebreaking capabilities. More often ice-transiting ships are simply called icebreaking ships. To ensure that icebreaking ships can ply these polar seas safely and efficiently, these ships are equipped with a range of unique structural features and safety requirements not seen in vessels designed for service in open water. In this section, we deal first with the general features of icebreaking ships and the regulations that govern them. Next we provide an overview of the icebreaking ships, in particular icebreakers and icebreaking freighters, drawing on specific examples of this type of vessel that are used in Russia. Russia possesses the world's largest fleet of icebreakers and ice-transiting ships and, through its NSR shipping activities, boasts more experience in this field of navigation than any other country. Finally, this section will survey recent research and development in the field of icebreaking ships, including some unique hull forms recently developed for operations in ice, with particular reference to an R&D project conducted in Japan on NSR commercial vessels.

4.1.1 Requirements for Icebreaking Ships

(1) General Characteristics

Ice-load-resistant hull

When ships navigate ice-covered waters, ice loads act on their hulls through contact with sea ice. This ice load can damage the ship's hull or its appendages, and even sink the ship in the worst cases. To ensure the safety of crew and cargo, ice-transiting ships must have solid hulls and mechanisms for reducing the ice load. In the 16th and 17th centuries, the Russians developed ships called *koch* and *lod'ya* for navigation near the coast of the icy White Sea. Some 18m long and built for a capacity of 30 people, these vessels had a uniquely round shape. Thanks to this design, when these ships were beset in ice and unable to move, the action of the ice pushed the ship up and out of harm's way, rather than crushing it (WP-28). This round hull form was born out of efforts to compensate for the technical shortcomings of the Russians, who could not build sufficiently sturdy ships at that time, rather than as an idea for protecting ships from ice loads. Much later, when Fridtjof Nansen commissioned Colin Archer to design the *Fram*, Archer adopted this idea (Figure 4-1-1). A cross-section of the *Fram* appears as a semicircle, in which both its stem and stern were rounded.

This concept of using a round hull form to lighten the ice loads was carried into the age of steel ships. One example from Japan is the *Fuji*, an Antarctic research vessel constructed in 1965; like the *Fram*, the *Fuji* featured a semicircular cross-section. In contrast, the *Shirase*, a successor to the *Fuji* built in 1982, abandoned the round hull form in favor of a hull form slightly slanted on both sides (Figure 4.1-2). With this design, if the ship were beset in ice the ice pressing on the hull would not be crushed by compression but fractured by bending, lightening the ice loads on the hull. Although great strides have been made in the knowledge of ice load and the technology of ship structure design, ice load remains a fearsome threat to the ships in ice. Compared to other hydrodynamic loads, ice load concentrates a great amount of load in a relatively small area. To withstand this ice load, even today, the hulls of icebreaking ships are reinforced with vastly more

4. Technological Aspects of NSR Navigation

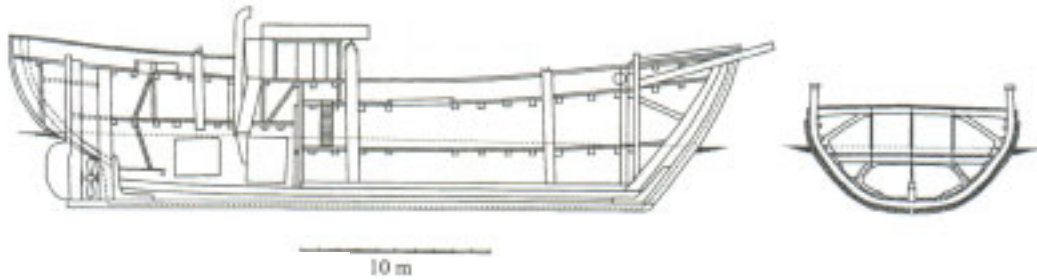

Figure 4.1-1 The Fram

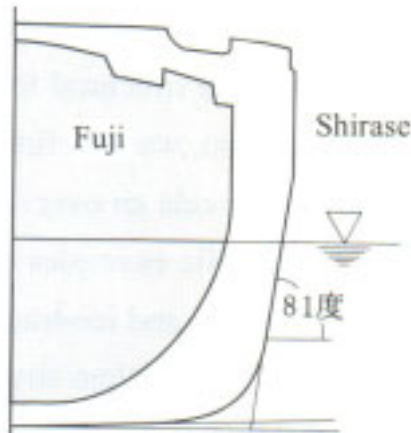

Figure 4.1-2 Comparison of midship cross-sections of the Fuji and the Shirase

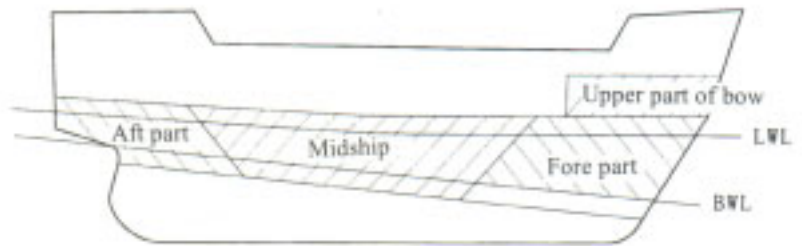

Figure 4.1-3 Ice belt on an icebreaking ship

steel than conventional vessels require. In particular, because the hull structure around the water line from stem to stern bears the brunt of the ice load, this part of the ship is outfitted with an extra layer of thickness called an ice belt (Figure 4.1-3). Also, the inside of the hull is supported by a lattice of finely spaced frames and beams.

Hull Form

The ice loads affect not only the structure of icebreaking ships but their hull forms as well. A key point in designing the hull form of ice-transiting ships is to design the bow to minimize the icebreaking resistance and to clear the broken ice blocks and pieces from the vicinity of the hull. The resistance of ships in ice arises from either breaking the ice around the ship or pushing it away—a far greater resistance than that of ships in open water. Moreover, the surrounding ice can interfere with the ship's propellers and even threaten the safety of the propulsion system; icebreaking ships have to be designed to minimize the ice-propeller interaction. These considerations were incorporated into the hull form of the Shirase, Antarctic research vessel of Japan (Figures 4.1-2, 4.1-4).

The Shirase shows the distinguishing features of an icebreaker above all in her bow. The bow lines incline markedly forward from the bottom to the water line; the stem angle in particular is as acute as 21°. Ice can be fractured in many different ways, but this distinctive shape fractures the ice around the ship vertically rather than horizontally, since ice is more easily fractured by bending than by compression. Thus the hull form of an icebreaking ship is principally designed to convert her momentum and propulsive force into vertical force, which breaks the ice efficiently through a bending motion. To realize this key icebreaking design criterion, the stem should have an acute angle, as seen in the Shirase. The Shirase also has a forefoot at the bottom of the bow. The role of the forefoot is to prevent the ship from riding up on top of the ice. When ice conditions are too severe for a ship to make substantial headway through continuous icebreaking, the ship must run backward once and then ram full ahead into the ice to break the impasse. This mode of operation is

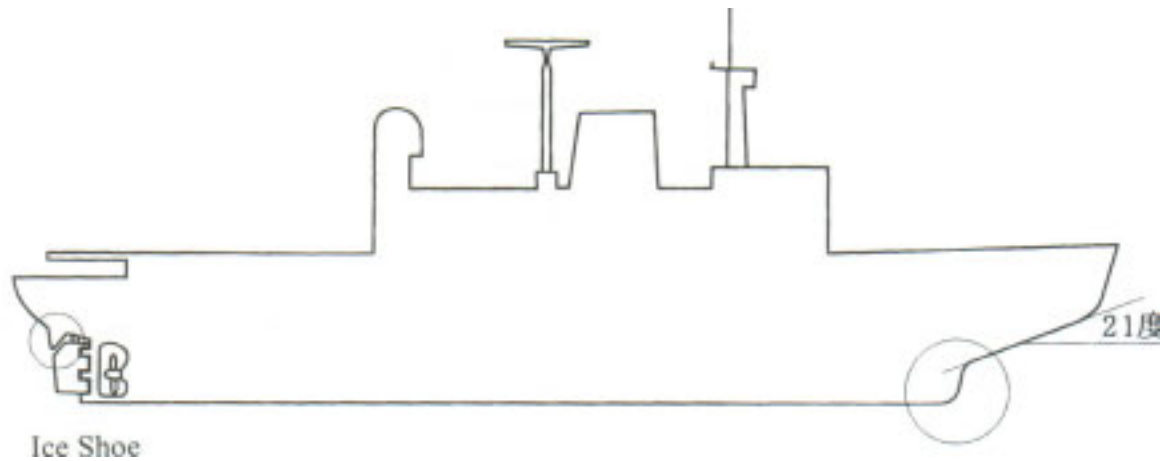

Figure 4.1-4 Features of an icebreaker as seen on the Shirase

called ramming mode. If the ship rides up too high onto the ice during ramming, the ship's stability may be threatened and she may be forced astern; the forefoot is thus useful to prevent a dangerous ride-up, particularly in ramming mode.

The Shirase has a rise-of-floor at her bottom. Rise-of-floor is a common hydrodynamic feature in the design of conventional freighters. The rise-of-floor of the Shirase works to push the broken ice blocks away from the keel and toward the gunwales, preventing unfavorable interactions between the propeller and ice pieces. The propulsion and steering systems, especially the propeller, shafting and a rudder, are often damaged by interaction with the ice blocks, sometimes causing serious accidents. Another device seen in the Shirase is the ice shoe, a triangular projection located in the stern above the rudder. It protects the rudder and propeller from the impact of ice fragments when the ship moves backward in ramming mode. This appendage is also unique to icebreaking ships.

In the preceding section we have used the Shirase as an example of an icebreaking ship to summarize her main features. However, to carry scientists, crew and cargo to the Antarctic efficiently and in appropriate conditions, the Shirase had to provide acceptable performance in open water as well as sufficient icebreaking capability. The Shirase was thus designed to fulfill both of these very different requirements adequately. Before she arrives in the Antarctic Ocean, the Shirase has to cross the trade-winds zone and endure the rigors of rough seas. Similarly, the NSR includes some regions of rough seas in the North Atlantic Ocean, so the overall performance of the NSR ships will have to be carefully considered on this point. Also, a number of ship designs incorporating high performance in ice-covered waters have recently been developed and demonstrated in Europe, where ships must often enter ice-covered waters as soon as they leave port. These novel designs for icebreaking ships are discussed in greater detail in section 4.1.3.

Propulsion systems

Navigation in ice-covered waters demands ships equipped with the following features. First, propulsion systems must be capable of delivering high power output in the low-speed range. In ice-covered waters, ships must quite frequently travel at low speeds under high resistance, so the propellers are working almost in bollard conditions. The second basic requirement is the capability to change operating mode rapidly, especially the ability to switch rapidly between moving full ahead and full astern. Ships operating in ice-infested waters are subject to an extreme range of operating conditions, and are frequently required to respond rapidly. The ramming mode described above is a particular case in point, where the ship must possess both sufficient astern power and a system capable of rapid switching between full ahead and full astern. Third, the propulsion system must be able to withstand the ice block impact. Protection of propulsion

4. Technological Aspects of NSR Navigation

systems from the damage, including propellers, shafts and propulsion machinery, is one of the most vital safety issues for the ships operating in ice. A number of protection mechanisms must be incorporated as discussed above; however, complete prevention is impossible. Contact of ice with a propeller often places heavy loads on the propeller blades and generates a sudden violent increase in the shaft torque, called ice torque. In sum, the propulsion system of an icebreaking ship must have either the sufficient strength to endure all of the loads described above or effective mechanisms to damp them.

A typical solution that meets the abovementioned requirements is the adoption of an electric propulsion system. An electric propulsion system offers a significant advantage over other systems, in that it can easily and precisely control field current of the motor, enabling it to change the number of revolutions of the propeller and direction of motion quickly, responding rapidly to abrupt variations in shaft torque. This system is presently used in many icebreakers. The most common prime mover of the electric propulsion systems is the diesel engine; Russia possesses a number of nuclear-powered icebreakers, but mainly for safety reasons they are not commonly used in other countries. Direct diesel propulsion systems are also commonly used in icebreaking ships, particularly in commercial fleets. These designs can provide rapid changes in output, such as switching between forward and reverse motion, through the adoption of a controllable-pitch propeller (CPP). An example of a propulsion system used in an icebreaking ship is illustrated in Figure 4.1-5 (Kishi and others, 1999). Another solution with considerable merit is the duct propeller. Because they offer high efficiency under high load, duct propellers are well suited to navigation in ice. Unfortunately, the duct happens to be blocked by ice fragments in the inlet. This problem has been addressed in some cases by mounting fins or flow-liners on the stern slightly forward of the duct.

In recent years the Azimuth system has attracted attention as a worthy propulsion system for icebreaking ships. The system has been installed in some vessels serving in ice-infested waters and shown promising early results. Like an outboard-engine, the Azimuth system itself rotates around the vertical shaft, rendering a rudder unnecessary. The electric motor that drives the propeller is housed in a cylindrical container, and is registered as a product under the name Azipod (short for Azimuthing Podded Drive). The greatest advantage of azimuth propulsion systems is the ability to turn the propulsion device in any direction, providing excellent turning performance that delivers far better maneuverability in ice than systems that rely on fixed rudders. Taking maximum advantage of the Azimuth's capability to provide propulsion in any direction, the concept has been developed of the Double-acting Azipod Ship (DAS), which can reverse direction of advance in ice or open water.

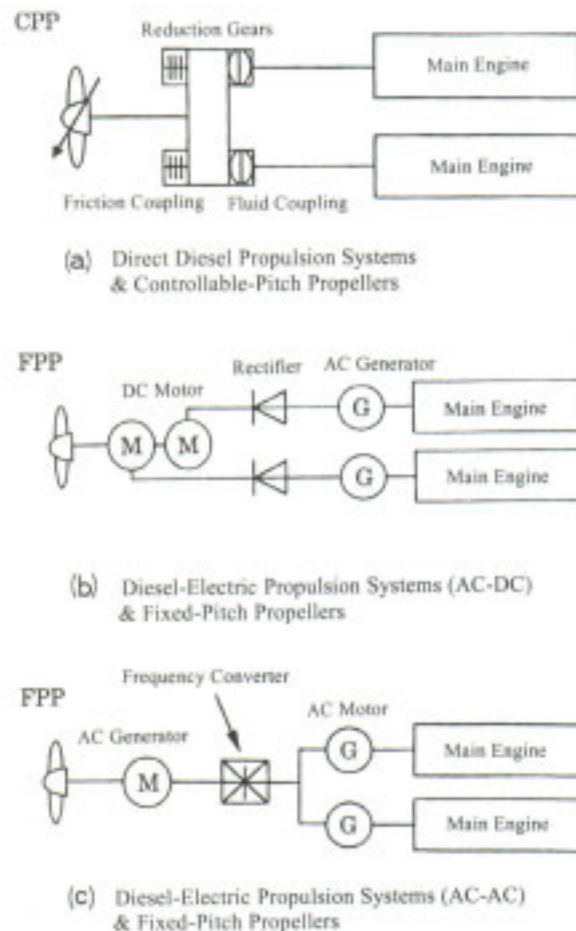

Figure 4.1-5 Example of a propulsion system used in an icebreaking ship

DAS is described in greater detail in section 4.1.3.

Paints for icebreaking ships

The hulls of icebreaking ships are often painted with special paints specifically developed for use in ice. These paints are especially used on the stem and the ice belt, which are in most frequent contact with the ice. One of the purposes of these specialized paints is to protect the shell plates of the hull. The Arctic Ocean poses an exceptionally harsh environment for protecting the shell plates from wearing and corrosion: In ice-covered waters, the shell plates are constantly exposed to contact with ice under intense ice pressure, scraping the paints, while the high concentration of dissolved oxygen in the water accelerates the corrosion rate of the shell. To withstand these tough conditions, the paints for use in ice need to be durable and resistant to peeling, and should also serve to reduce the friction between the hull surface and the ice. When an icebreaking ship is in the process of icebreaking, various forces act on the ship, but friction force between the hull and the ice is one of the most important. Several kinds of paints for particular use in ice with low friction coefficients are being developed and put into use, since ice friction depends heavily on the characteristics of the hull surface. In Finnish and Russian icebreakers, use of stainless-clad steel plates in the ice belt was tested, to improve resistance to wear and corrosion and to reduce the friction between the hull and the ice as well. The stainless-steel surface can provide a paint-free ice belt, but the electric potential difference between two different metals quickens steel part corrosion. Additional anti-corrosion systems were therefore adopted in these cases.

(2) Regulations and classifications of icebreaking ships

Ships are generally divided into a number of categories according to type and function. To ensure the safety of all types of vessels, each vessel is subject to various rules and standards regarding appropriate use of the vessel, the environment and other issues, as established by the classification societies and other organizations. The structural and machinery requirements for icebreaking vessels are established by several classification societies, including the Russian Register of Shipping (RR), Lloyd's Register of Shipping (LR), the American Bureau of Shipping (AB), Norway's Det Norske Veritas (NV) and Nippon Kaiji Kyokai (NK). In addition, responsible government agencies establish rules for the ship and operations in ice with respect to the Baltic Sea, the Canadian Arctic and the NSR. The Baltic Sea is governed by the Finnish-Swedish Ice Class Rules (FSICR), while the Canadian Arctic is regulated by the Canadian Arctic Shipping Pollution Prevention Regulations (CASPPR). Furthermore, Russia has proclaimed the "Regulations for Navigation on the Seaways of the Northern Sea Route." For detailed information on the design and fittings requirements of Russian icebreaking ships, see section 4.3.3.

In these classification society regulations, ice-transiting ships are graded into "ice-strengthened ships" (also called "ice-worthy ships") and "icebreakers" according to the ice conditions they are likely to encounter, the seas they navigate and their icebreaking capability, and appropriate rules are applied for each (Table 4.1-1). Ice-strengthened ships and icebreakers are further divided into several ice classes. The term "ice-strengthened ship" suggests a ship with sufficient durability to withstand the pressure of surrounding ice, which implies that all ice-transiting ships are ice-strengthened ships. In fact, the expression is used to contrast these ships with ships that are capable of serving as icebreakers. Icebreakers are vessels whose purpose is to provide support and emergency assistance for other vessels in ice-infested waters and/or to conduct various monitoring and research tasks, and which are made capable of such service by their durable structure and their function of conducting unescorted operations in ice at any time. Most ice-strengthened ships, in contrast, have cargo holds and are designed to operate under rather easier conditions than icebreakers, satisfying the

4. Technological Aspects of NSR Navigation

minimum conditions of specification and outfittings to navigate in ice-covered waters. In a practical sense, however, the regulations to classify the vessels into icebreakers and ice-strengthened ships offer only a rough guideline, and the choice of a ship classification is often dependent on the decision of the ship's owner. In some cases, the ships designed and classified as ice-strengthened ships have certain level of icebreaking capabilities. For example, the SA-15, a typical Russian freighter capable of operating in the Arctic which is described in detail later, was constructed with ice-strengthened grade according to the Russian classification and is capable of continuous icebreaking of ice up to 1m thick. Vessels that have some slight icebreaking capability, even when classified as ice-strengthened, are sometimes defined as icebreaking ships. It should be noted that terms such as "ice-going", "ice-transiting", "ice-worthy" and "icebreaking" frequently appear with different definitions in the literatures.

In terms of regulations governing ice-strengthened ships, a broad similarity is recognized among the rules of the various classification societies. For example, NK's regulations on ice-strengthened ships are essentially based on FSICR regulations. FSICR classifies ice-strengthened ships from the very strict IA super class to the more general ID class but theoretically accepts corresponding classes established under other regulations. This is in contrast with the case of icebreakers. A few classification societies, such as NK and FSICR, carry no specific rules for icebreakers. In fact, none of the standards of administrations and classification societies are readily comparable, or even compatible with one another. They are not consistent, as they are mostly based on different concepts of the forces experienced at the ship and ice interface.

As the foregoing discussion shows, while a certain amount of harmonization exists among the classification societies' regulations regarding ice-strengthened ships, essentially each classification society sets its own rules. This problem has been recognized and the relevant organizations are working toward one set of harmonized international standards for the construction and navigation of ships in polar seas, in particular in the northern ice-covered waters. (Karaminas, 1999). The opening of the NSR forms a substantial

Table 4.1-1 Ice Classes of Classification Societies

Ice-strengthened vessel

Classification Society	Ice class					
	high			low		
RR	ULA UL	L1	L2	L3	L4	
LR	IAS	IA	IB	IC	ID	
AB	IAA	IA	IB	IC		
NV	IA*	IA	IB	IC		
NK	IA super	IA	IB	IC		
FSICR	IA super	IA	IB	IC	II	
CASPPR	A	B	C	D	E	

Icebreaking vessel

Classification Society	Ice class					
	high			low		
RR	LL1	LL2	LL3	LL4		
LR	AC3	AC2	AC1.5	AC1		
NV	Polar-30	Polar-20	Polar-10 Ice-15	Ice-10	Ice-05	
CASPPR	CAC1	CAC2	CAC3	CAC4		

This table shows only a rough equivalence of ice-class between the classification societies.

background to these initiatives. This is because a wide variety of ships under various registrations will ply the Arctic Ocean when full-scale international commercial shipping begins in the NSR, and a consistent set of rules will be needed for the rational evaluation of ship safety. A working committee has been established to examine this issue of harmonization, consisting of related parties from Canada, Russia, Finland, the United States and others. After a series of deliberations that began in 1993, in 1998 this committee submitted a draft report of “The International Code of Safety for Ships in Polar Waters” (Polar Code) to the International Maritime Organization (IMO). The Polar Code called for in this proposal covers a wide range of topics, including construction requirements, equipment and operational requirements. This Code unifies the former classifications of icebreakers and ice-strengthened ships as well as their sub-classifications into Polar Class (PC) 1 through 7 (Table 4.1-2). For each of these Polar Classes, the ice conditions and time of season in which each applicable type of ship can navigate are stipulated. Although the Polar Code does not draw a distinction between icebreakers and ice-strengthened ships, Classes PC1 through PC5 can be said to correspond to icebreakers, while PC6 and PC7 correspond to the higher grades of ice-strengthened ships. The Polar Code also defined the term “polar seas,” with some allowance for geography, as seas above 60° N. Therefore, all ships plying the NSR fall under the Polar Code. At this point, however, the Polar Code remains at the proposal stage and is not intended to be obligatory.

As for the requirements of ship structures and marine engines in the Code, the International Association of Classification Societies (IACS) has established an Ad-hoc Group for Polar Ship Unified Requirements, which will form an important element of the overall harmonization of requirements for polar ships. This body, which has been endorsed by the IMO and by all national administrations with responsibilities over Arctic Waters, has formed an Outside Working Group to develop a Code that includes rules governing design and operational aspects of ship safety. However, some significant areas of contention remain, such as a proposal to exclude the Antarctic Ocean (south of 60° S) from the Polar Seas (Karaminas, 1999). A final decision by the IMO is currently pending, subject to hearings and coordination among the relevant governments and agencies.

Table 4.1-2 Class Descriptions

Polar Class	Limiting Ice Description
PC1	Year-round operation in all Polar Waters
PC2	Year-round operation in moderate multi-year ice conditions
PC3	Year-round operation in second-year ice with old ice inclusions
PC4	Year-round operation in thick first-year ice with old ice inclusions
PC5	Year-round in medium first-year ice with old ice inclusions
PC6	Summer and autumn operation in medium first-year ice with old ice inclusions
PC7	Summer and autumn operation in thin first-year ice with old ice inclusions

4.1.2 Icebreaking Ships in Russia

(1) Icebreaking freighters of the SA-15 class

Marine transportation in ice-infested waters has been developed in the Baltic Sea, the Great Lakes, the St. Lawrence River, the Barents Sea, some regions of the NSR and the Canadian Arctic. In all of these regions, freighters and tankers with ice-going capability have been constructed and used for commercial shipping of a wide range of cargoes (Table 4.1-3). In Russia, under the planned economy of the Soviet era, an extraordinary fleet of polar ships was established to handle such shipping in the NSR and major rivers such as the Ob and

4. Technological Aspects of NSR Navigation

Yenisey. According to data from early 1997, the fleet consisted of as many as 150 L1 Ice Class icebreakers (WP-167). Icebreaking cargo ships of the SA-15 class formed the core of the Soviet fleet. Even today the SA-15s are the most commonly used icebreaking cargo ships, not just in Russia but around the world. The SA-15 aptly illustrates the main features of icebreaking freighters. “SA-15” is a project name denoting a SubArctic 15,000 DWT Ship, for a long series of combined bulk, cargo and RORO vessels.

Table 4.1-3 Icebreaking freighters in common use worldwide (Part 1)

Name	LENA	IVAN PAPANIN	AMGUEMA	KAPTAIN GOTSKIY	IGOR GRABAR	SAMOTLOR	DMITRIY DONSKOY	PIONER MOSKVY	MIKHAIL STREKALOVSKIY
Class	RR	RR	RR	RR	RR	RR	RR	RR	RR
Ice Class	ULA	ULA	UL	ULA	UL	UL	UL	UL	UL
Number of sister vessels	5	3	14	6	6	14	13	22	12
Registration	Russia	Russia	Russia	Russia	Russia	Russia	Russia	Russia	Russia
Function	Cargo	Cargo	Cargo	Cargo	Cargo	Cargo	Cargo	Cargo	Cargo
Year of Construction	1954-57	1962	1962-72	1965-72	1973	1975-77	1977	1973-80	1981
Main particulars									
Length overall(m)	130.2	166.3	133.1	133.0	97.3	160.0	162.1	130.0	162.1
Length between perpendiculars (m)	117.3	147.1	123.0	118.4	90.1	148.0	154.9	119.0	154.8
Width (m)	19.0	22.3	18.9	18.5	16.0	23.0	22.9	17.0	22.9
Depth (m)	11.2	13.4	11.6	11.6	7.7	12.9	13.5	8.5	13.5
Draft (m)	8.3	9.0	9.1	8.9	6.4	9.2	9.9	7.3	9.9
Gross tonnage (t)	7,500	14,400	7,968	7,684	3,184	13,204	13,481	4,814	13,520
Volume of displacement (m ³)	12,600	21,025	13,540	13,840	6,535	24,570	27,340	10,010	27,340
Dead Weight Tonnage (DWT)	7,439	10,105	8,700	8,723	4,054	17,200	19,885	6,780	19,252
Propulsion system									
Max. output (MW)	6.0	13.2	5.3	5.3	2.8	8.5	8.2	4.5	8.2
Number of shafts	1	1	1	1	1	1	1	1	1
Main engine	Diesel dc-dc	Diesel Direct drive	Diesel dc-dc	Diesel ND	Diesel Direct drive	Diesel Direct drive	Diesel Direct Drive	Diesel Direct Drive	Diesel Direct Drive
Propellers	1*FP	1*CP	1*FP	1*FP	1*FP	1*FP	1*FP	1*FP	1*FP
Propeller diameter (m)	ND	5.7	ND	ND	ND	ND	5.15	ND	5.15
Number of blades	4	4	ND	4	4	4	ND	4	ND
Nozzle	No	Yes	No	No	No	No	No	No	No
Performance									
In open water (knots)	15.4	17.1	15	15	13.2	15.7	15.2	15.6	15.2
In ice (knots/m)	2/0.73	1.5/1.1	2/0.7	2/0.7	ND	ND	ND	ND	ND

(Part 2)

Name	FINN CARRIER	MT KHISLA	MT LUNNI	MT LUNNI modified	MV ARCTIC	MV ARCTIC modified	MV FEDERAL BAFFIN	THULELAND	DAMSA DAN
Class	ND	FSIR	DNV	DNV	LR	LR	DNV	DNV	ND
Ice Class	ND	IA	IA Super	IA Super	IA Super	IA Super	IA	IA Super	ND
Number of sister vessels	1	1	4	2	1	1	2	1	1
Registration	Finland	Finland	Finland	Finland	Canada	Canada	Canada	Sweden	Denmark
Function	Cargo	Tanker	Tanker	Tanker	OBO	OBO	Cargo	Cargo	Cargo
Year of Construction	1969	1974	1976/77	1993-95	1978	1986	1995	1977	1973
Specifications									
Length overall (m)	ND	130.5	164.4	164.4	209.6	220.8	190.0	185.9	ND
Length between perpendiculars (m)	129.9	123.6	150.0	150.0	196.6	206.0	183.0	177.0	125.0
Width (m)	24.6	17.6	22.2	22.2	22.9	22.9	30.5	26.5	18.1
Depth (m)	17.3	8.0	12.0	12.0	15.2	15.2	16.6	15.1	11.3
Draft (m)	5.7	6.6	9.5	9.5	10.9	11.5	11.5	11.0	7.4
Gross tonnage (t)	ND	4,681	10,975	10,936	19,420	20,236	27,078	22,157	ND
Volume of displacement (m ³)	10,567	ND	ND	ND	38,104	38,466	ND	ND	12,091
Dead Weight Tonnage (DWT)	ND	6,863	15,955	15,748	28,094	28,373	43,706	31,400	ND
Propulsion system									
Max. output (MW)	8.2	3.7	11.5	13.8	10.9	10.9	11.5	11.2	6.8
Number of shafts	2	1	1	1	1	2	1	1	1
Main engine	Diesel Direct Drive	Diesel Direct Drive	Diesel Direct Drive	Diesel Azipod	Diesel Direct Drive	Diesel Direct Drive	Diesel ND	Diesel Direct Drive	Diesel Direct Drive
Propellers	2*FP	1*CP	1*CP	1*FP	1*CP	1*CP	1*FP	1*FP	1*CP
Propeller diameter (m)	ND	ND	5.45	5.65	5.23	5.23	6.2	ND	ND
Number of blades	4	4	4	4	4	4	4	4	ND
Nozzle	No	No	No	No	Yes	Yes	No	No	No
Performance									
In open water (knots)	17	15	14.5	14.5	15	15	14	ND	17.5
In ice (knots/m)	ND	ND	2/1.0	2/1.0	3-4/0.61	2/1.5	ND	ND	2/0.67

(Part 3)

Name	NORILSK (SA-15)	VENTSPILS	SEVMORPUT	PAVLIN VINOGRADOV	PARTIZANSK	KAPITAN GONCHAROV	IGOR ILYINSKIY	VITUS BERING
Class	RR	RR	RR	RR	RR	RR	RR	RR
Ice Class	ULA	UL	ULA	UL	UL	UL	UL	ULA
Number of sister vessels	19	10	1	7	11	3	8	3
Registration	Russia	Russia	Russia	Russia	Russia	Russia	Russia	Russia
Function	Cargo	Tanker	Lash	Cargo	Tanker	Cargo	Cargo	RORO
Year of Construction	1982-87	1983-86	1988	1987-90	1988-90	1989-91	1990-91	1986-89
Specifications								
Length overall (m)	174.0	113.0	260.3	131.6	97.4	131.6	132.7	159.8
Length between perpendiculars (m)	159.6	105.3	228.8	122.0	90.1	122.0	122.0	142.4
Width (m)	24.0	17.1	31.6	19.3	14.2	19.3	19.9	22.1
Depth (m)	15.2	8.5	18.3	8.8	6.5	8.8	8.8	12.0
Draft (m)	9.0	7.2	11.7	7.0	4.9	7.0	6.9	8.5
Gross tonnage (t)	16,500	5,154	38,226	6,395	2,968	6,396	7,120	13,514
Volume of displacement (m ³)	25,900	9,400	54,380	11,249	4,855	11,170	11,754	18,900
Dead Weight Tonnage (DWT)	14,700	6,297	33,980	7,850	2,833	7,700	8,256	9,200
Propulsion system								
Max. output (MW)	15.4	4.4	29.4	4.7	2.9	4.7	5.1	11.5
Number of shafts	1	1	1	1	1	1	1	1
Main engine	Diesel Direct Drive	Diesel Direct Drive	Nuclear Turbo electric	Diesel Direct Drive	Diesel Direct Drive	Diesel Direct Drive	Diesel Direct Drive	Diesel Direct Drive
Propellers	1*CP	1*FP	1*CP	1*FP	1*CP	1*FP	1*CP	1*FP
Propeller diameter (m)	5.6	ND	6.7	ND	ND	ND	ND	ND
Number of blades	4	4	4	4	4	4	4	4
Nozzle	No	No	Yes	No	ND	No	No	Yes
Performance								
In open water (knots)	18.1	15.2	20.8	14.9	13.5	15	15.2	16.4
In ice (knots/m)	2/1.0	ND	ND	ND	ND	ND	ND	2/0.9

During a period beginning in 1982 and ending in 1987, a total of nineteen SA-15 multipurpose freighters, of which the Noril'sk was delivered first, were built for the Soviet system at two Finnish shipyards, Wartsila and Valmet. As of 1998, nine of these vessels were employed by the Murmansk Shipping Company, eight by the Far East Shipping Company, and a further two by the Sakhalin Shipping Company (WP-107). The Murmansk Shipping Company's fleet includes the Kandalaksha, used in 1995 for the experimental voyage in the NSR organized by SOF.

The SA-15 is 174m long and 24m wide, with a limited draft of 9.0m in the shallow waters of the NSR. In other seas its draft is 10.5m. Built as a ship in the ice-strengthened class, the SA-15 was designed by ULA of the RR. It is equipped with an RO/RO deck and a stern-ramp to discharge cargo directly to fast ice in winter. The ship has a wedge-type icebreaking bow and can continuously break level ice 1 m thick. In terms of NSR operations, the SA-15 is designed to

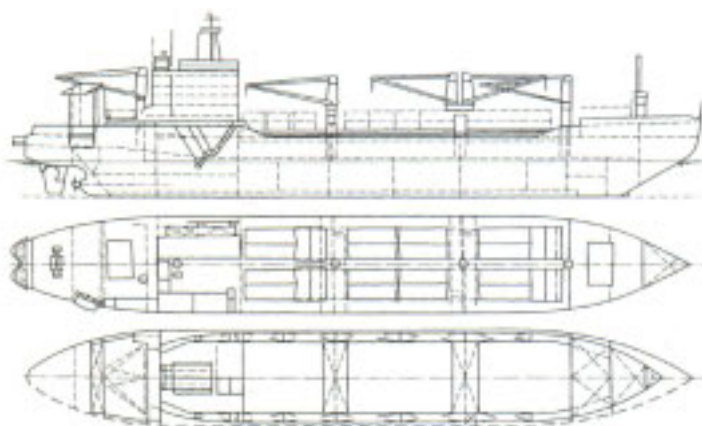

Figure 4.1-6 Profile and general layout of the SA-15 class ship



Figure 4.1-7 The SA-15-class ship

4. Technological Aspects of NSR Navigation

navigate unescorted in summer and with an assistance of an Arktika-class icebreaker in winter.

The SA-15s feature several innovative systems for icebreaking freighters. The ship is directly driven by diesel engines through reduction gears, being equipped with controllable-pitch propellers (CPP). As described above, CPPs are a useful design for icebreaking ships, as they provide rapid power supply and quick response for switching between full ahead and astern, in particular in ramming mode. Also, both friction and fluid couplings are installed between the main engines and the reduction gear. The former is employed when navigating in ice to protect the propulsion system from ice torque, and the latter is used in open water or light ice conditions to improve fuel efficiency. (Figure 4.1-5 (a)). Another innovative feature of the SA-15, an air-bubbling system, is fitted to reduce friction and accretion between the hull and snow or ice at anchor in the winter. The bow also incorporates an observation deck for monitoring of ice conditions. The deck is linked to the accommodation space by a narrow, sheathed corridor, so that the crew can check conditions without venturing out to the exposed sections of the ship.

(2) Icebreakers

In addition to the SA-15 freighters, built for polar-sea shipping, the Soviets constructed a powerful fleet of icebreakers to support these vessels in NSR waters. These NSR icebreaker support operations are today divided east and west between two organizations, the Far East Shipping Company (FESCO), headquartered in Vladivostok, and the Murmansk Shipping Company (MSC) (Table 4.1-4). The icebreakers in question belong to the Russian government, which lends the vessels to the two shipping firms under an operating contract (WP-96). Currently FESCO's icebreakers suffer from a low availability rate, so in practice only MSC is operating Russia's icebreaker fleet.

The core of the Russian icebreaker fleet consists of five Arktika-class nuclear icebreakers (the Arktika, Sibir, Rossiya, Sovetskiy Soyuz and Yamal), all of which were constructed during the Soviet era. Represented by the Arktika-class icebreakers, with 75,000HP propulsion systems and the ability to perform continuous breaking of ice 2.3m thick, Russia boasts the most powerful icebreaker fleet in the world. In addition, two shallow-draft icebreakers designed for coastal and river operation, the Taymyr and Vaygach, were jointly developed by Finland and Russia. Both of these nuclear-powered icebreakers are presently operated by MSC. Russia's diesel-electric icebreakers, on the other hand, were constructed in Finland and are allotted to MSC and FESCO. As described in the following section, most of Russia's icebreaker fleet uses the conventional,

Table 4.1-4 Russia's icebreaker fleet

Name	Operating company	Year constructed	Propulsion system /shaft horsepower (PS)	Remarks
Arktika	MSC	1975	Nuclear /75,000	Due for decommissioning in 2000
Sibir	MSC	1977	Nuclear /75,000	Due for decommissioning in 2000
Russiya	MSC	1985	Nuclear /75,000	Used in NSR
Sovetskiy Soyuz	MSC	1990	Nuclear /75,000	Used in NSR
Yamal	MSC	1993	Nuclear /75,000	Used in NSR
Taymyr	MSC	1989	Nuclear /44,000	Shallow draft
Vaygach	MSC	1990	Nuclear /44,000	Shallow draft
Yermak	FESCO	1974	Diesel-electric /41,400	Due for decommissioning in 2000
Admiral Makarov	FESCO	1975	Diesel-electric /41,400	
Krasin	FESCO	1976	Diesel-electric /41,400	
Kapitan Solokin	MSC	1977	Diesel-electric /24,800	Remodeled as a WAAS ship
Kapitan Nikolaev	MSC	1978	Diesel-electric /24,800	Remodeled with a Conical bow
Kapitan Dranitsyn	MSC	1980	Diesel-electric /24,800	
Kapitan Khlevnikov	FESCO	1981	Diesel-electric /24,800	

wedge-type bow design, despite the recent development and commercialization of an improved bow shape that has demonstrated excellent icebreaking performance. Three of the diesel-electric icebreakers—the Kapitan Sorkin, Kapitan Nikolayev and Kapitan Dranitsyn—were constructed as shallow-draft models. The Kapitan Sorkin and Kapitan Nikolayev were subsequently remodeled, the former as a WAAS vessel and the latter with a conical bow.



Figure 4.1-8 A nuclear-powered icebreaker
(the Arktika)

As the foregoing discussion indicates, Russia's fleet of icebreakers is the world's strongest, in terms of both icebreaking capability and number of ships. Unfortunately, Russia has built no new icebreakers since the construction of the Yamal in 1993. Construction of the Arktika-class nuclear-powered icebreaker Ural began in 1985, but fifteen years later its completion is nowhere in sight (the vessel's name has been changed to Victory in World War II). Despite the lack of new ships, the three oldest icebreakers, the Arktika, Sibir and Yermak, are scheduled to be retired in 2000. The Arktika and Sibir are two of the five 75,000HP icebreakers, while the Yermak was at the heart of Russia's diesel-electric icebreakers. Given the turmoil in Russia's economic condition, no plans to construct successors to these craft are expected to materialize at all in the near future. The demand for the services of these ships in NSR applications is far less than the strategic demand during the Soviet era, and indeed demand for icebreaker support of commercial shipping is shrinking. Some of these vessels are now used to serve the Arctic tourism industry. Nonetheless the polar icebreakers form a critical component of the NSR system. Just as the existing icebreakers are coming to the end of their service lives or becoming over-aged, the maintenance and replacement of Russia's icebreakers is becoming increasingly difficult.

(3) Escort operations

The operation of commercial vessels in the NSR is conducted in one of two modes. The first is unescorted mode, or independent operation, in which the vessel navigates in ice-infested waters on its own. When severe ice conditions are expected to produce significant delay in navigation or may disable the ship, this mode is eschewed in favor of the second: escorted navigation, or ice escort. In this mode, a convoy is formed with an icebreaker whose icebreaking capability is stronger than the commercial ship's. Under ice escort, the icebreaker takes the lead, opening a path through the ice for the commercial vessel. The composition of the convoy is determined by the condition of the ice; the more severe the ice conditions, the fewer ships are escorted by a single icebreaker. Generally, if ice concentration is 5/10 or 6/10, one icebreaker may escort three or four commercial vessels; with concentration of 8/10, the number of escorted ships is dropped to one or two. Thanks to Russia's wealth of experience in NSR operations, the following points of convoy formation have been learned with respect to navigation in ice-covered waters (WP-108).

- * When convoys are formed with ships of different icebreaking capabilities, the ship with the poorest capability follow immediately behind the icebreaker and the ship with the greatest capability brings up the rear.
- * When multiple icebreakers support a single convoy, the icebreakers are positioned at the front and middle of the convoy. The middle icebreaker assists ships that become unable to operate.

4. Technological Aspects of NSR Navigation

- * When a convoy is formed of ships with equivalent icebreaking capability but different widths, the commercial vessels are arranged in descending order of width, with the widest ships at the front and the narrowest at the rear.
- * The worse the ice conditions are, the smaller the number of escorted ships is and the smaller the distance is between ships.
- * If any of the ships in the convoy is prevented by the ice from moving forward, the icebreaker frees that ship by passing on the side of the ship.
- * During the operation described above, great care must be taken to the ship-to-ship interactions between the icebreaker and the distressed ship.
- * Similarly, in the same situation, when the icebreaker moves at low speed, a hazard of damage exists to the hull, propulsion system, rudder etc. of the distressed ship, due to ice blocks in the water between the two ships.

Under extreme ice conditions, particularly when wind or tides cause pressure to form in the ice, the channel created by the escorting icebreaker may close up before the escorted ship has time to pass through, curtailing the speed of the vessel and causing frequent stoppages. In these cases the escorting icebreaker may be obliged to tow the escorted ship. Although this towing is sometimes performed using a cable, under extremely harsh ice conditions a method developed uniquely by Russia is used, known as close-towing or fork-towing (Figure 4.1-9). In close-towing, the icebreaker tows the escorted ship with its bow attached directly to a notch in the icebreaker, called the stern notch (Figure 4.1-10). According to data regarding the towing of an SA-15 commercial ship by the nuclear icebreaker Arktika through 160-200cm first-year ice, the convoy was able to muster a speed of only two knots without towing, but was able to improve this speed to four knots using close-towing—the same as the Arktika's speed when navigating alone (WP-107). When the escorted ship's displacement exceeds that of the escorting ship, the escorting ship is known by experience to suffer a decrease in maneuverability. The largest ship that an Arktika-class nuclear icebreaker can escort using close-towing is the S-15 class ship with displacement of roughly 25,000t.

When navigating in ice-covered waters by convoy, especially when using close-towing, the ratio of breadths of the icebreaker and the escorted vessels is important. During ice navigation, though the conditions of the ice and the contours of the ship are factors as well, in level ice a ship will form a channel behind it that is slightly wider than the widest point of the ship. Therefore, if the escorted ship is wider than the escort ship, the edge of the channel will come into contact with the forward shoulder of the vessel, causing friction and new resistance components, as the shoulder part cannot break ice effectively. It is therefore important to ensure that the widths of the two ships do not have this sort of proportion to each other. On this point, it is



Figure 4.1-9 Close-towing

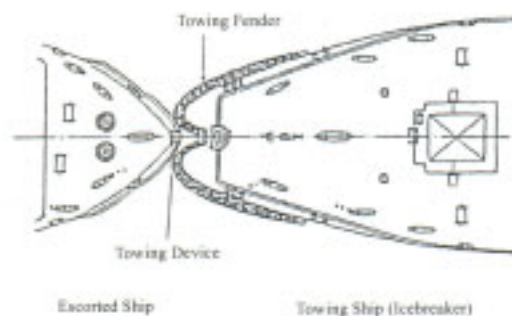

Figure 4.1-10 Stern notch

interesting to observe the widths of Russian icebreakers and icebreaking commercial ships. Figure 4.1-11 illustrates the width and draft of the commercial polar-sea ships of Russia and other countries, plotted as a function of ship length. The ratio of width to length of Russian ships is concentrated in the 1:6-1:7 range, narrower than its icebreakers, which lie in the range of about 1:5. In contrast, the icebreaking commercial ships of other countries are scattered across a broad range of width/length ratios. Except for the unusually large nuclear-powered LASH ship Sevmorput, Russia's icebreaking commercial ships are no wider than the SA-15 type ship's 24m. Russia's icebreakers and icebreaking commercial ships therefore adhere to a consistent design enabling them to work together in escort operations. As Figure 4.1-11 illustrates, again with the Sevmorput as the sole exception, the draft of Russian icebreaking commercial ships is no greater than 10m. The shallow waters of the NSR impose limitations on their drafts.

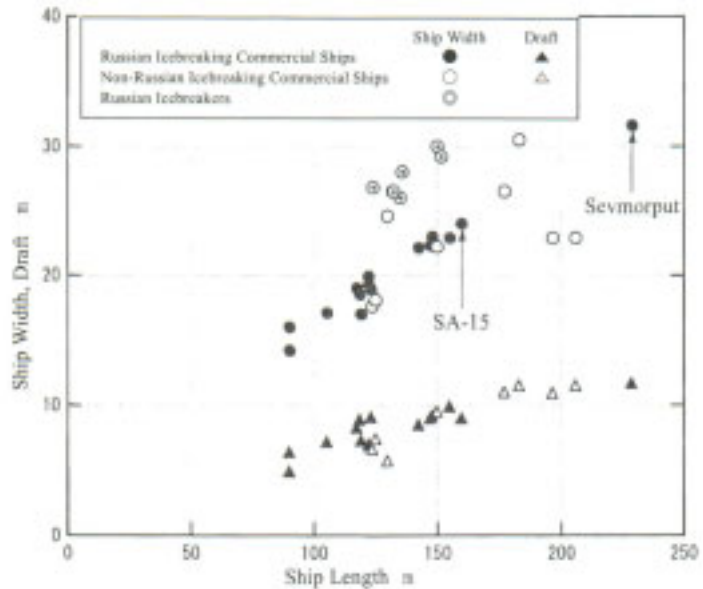

Figure 4.1-11 Relation among the length, width and draft of polar ships

4.1.3 Research and Development in Icebreaking Ships

(1) Recent achievements in icebreaking ships

Systematic research and development in the field of polar navigation has barely begun. Furthermore, the optimum conditions of the various technologies involved in icebreaking operations often depend on the condition and characteristics of the ice and the operational mode of the ship. The present maturity of ordinary ship designs is still a distant goal for icebreaking technologies. Stated in a more positive way, the room for further technological innovation is enormous, and the development and commercialization of technologies based on new approaches is continuing. Especially noteworthy is the recent progress in the design of hull forms for icebreaking ships. There are several reasons why these advances are happening now. First, researchers' understanding of the mechanical properties of ice and of the mechanisms of icebreaking are steadily deepening. Second, improved methods of gathering and analyzing data on ship structures have brought greater assurance in the area of the structural safety of novel hull forms. A further factor is the development of ice tanks and experimentation as reliable tools for testing new ship models and their effectiveness.

The primary objective of development of icebreaking hull forms is to improve icebreaking performance by reducing the resistance from ice. Because the bow form governs icebreaking behaviors, developers have proposed a wide range of bow shapes designed to minimize ice resistance. The conventional bow form of icebreaking ships is a wedge type with V-frame lines. The wedge type is widely adopted because it offers a practical tradeoff between icebreaking and hydrodynamic requirements. However, recent research has demonstrated that bows with a round stem and blunt water line provide lower icebreaking resistance. The

4. Technological Aspects of NSR Navigation

bow form shown here is called a spoon bow because its convex form bears a striking resemblance to a spoon (Figure 4.1-12). The bow lines of the spoon bow contact ice at a much lower angle than the wedge-type, and the spoon bow can break ice fully by bending. Other round bow forms are sometimes called the cylindrical bow and the conical bow; in practice there is no clear distinction between these types.

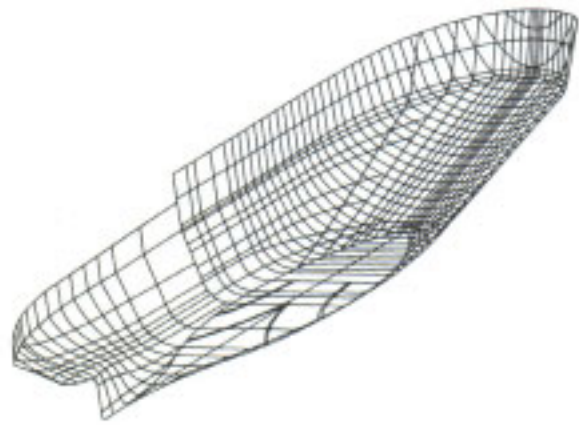

Figure 4.1-12 Spoon bow (Kapitan Nikolaev)

The spoon bow follows conventional working theories, reducing ice resistance predominantly by bending the ice to fracture it. Another design that uses a radically different mechanism is the WAAS bow (Freitas, 1978). In this design, the two sides at the bottom of the forward part hang lower than the center, forming sharp edges. These edges place a vertical downward force to shear the ice (Figure 4.1-13). Due to forward motion of the ship, the ship bottom successively pushes down the ice sheared off by the ship's edges and breaks it by bending. The broken ice pieces are finally pushed aside below the ice at both sides of the ship. The WAAS bow was conceived out of the observation that the shearing strength of ice is usually lower than the flexural strength, but other benefits have been obtained as well. The edges of the channel formed in the wake of the icebreaker are neat and cleanly defined. Moreover, the broken ice fragments are pushed aside below the ice at both sides of the ship, so the channel is kept largely clear of these fragments (Figure 4.1-14). This improvement is an important factor for the safety of the following ship during ice escort.

In some recently developed icebreaking hull forms, together with the spoon or WAAS bow, a reamer hull form has been designed. In this design concept the parallel and aft parts of the hull are made narrower than the forebody and a reamer is fitted between them. One of the purposes of the reamer is to reduce the resistance of the parallel body. In normal hull designs, resistance is generated by friction between channel edges and the hull surface of the parallel body and also by complex interactions between the hull surface, channel edges and broken ice pieces entrapped in the gap. The reamer model is expected to reduce this component of resistance by making the gap formed by the bow wider with respect to the parallel section. The second objective of the reamer is to improve the ship's turning ability. Except in specially built vessels, polar ships have no icebreaking capability in the stern and are unable to perform icebreaking while turning. The ship's turning ability is then decided by the relative turning angle of the ship in the formed channel and the left-right difference in icebreaking features around the

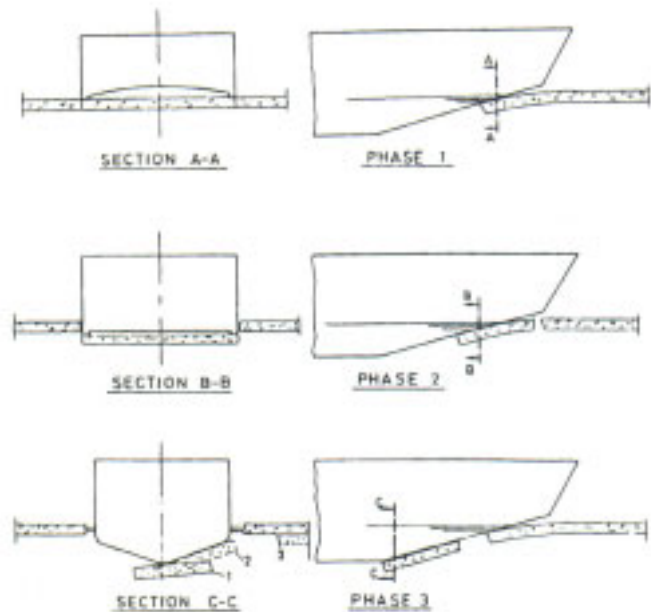

Figure 4.1-13 Ice fracture mechanism of the WAAS bow (from Freitas, 1978)

bow. Ships that incorporate a reamer can tolerate a high turning angle in the channel, improving their manoeuvrability in ice. However, to prevent damage to the rudder, care must be taken to avoid an excessive turning rate.



Figure 4.1-14 Channel formed by a WAAS ship

These innovations in icebreaking are applied in a wide range of ships and their superior performance relative to conventional designs has been clearly demonstrated. Nonetheless the focus of their development has been ice navigation, and it must be noted that open-water performance

is sacrificed to some extent in these designs. The open-water resistance of these types of ships is actually higher than that of conventional designs, and ship behavior in rough seas is conspicuously poor. Ships with spoon bows, for example, suffer from flare slamming due to impulsive wave loads, causing tremendous vibrations that are known to open cracks in the ships' upper structures. Just as in commercial ships, careful consideration of open-water as well as icebreaking performance will have to be taken, and in many cases the more extreme designs will have to be discarded in favor of more conventional approaches.

One idea conceived to provide both icebreaking and open-water capability is the Double-acting Azipod Ship (DAS). The DAS is equipped with an azimuth propulsion unit in its stern. The form of the bow is favorable for open water operations. In icebreaking operations, the ship is turned around and the "stern" goes first. Of course, this requires the stern to have an icebreaking hull form as well. The DAS was developed in Finland on the basis of a wealth of accumulated experience in operations with bow propellers in the Baltic Sea. In spite of potential cares about hazardous interactions between ice and propeller and lack of sufficient full-scale data, the DAS design holds great promise for future NSR vessels. Except for some unusual designs, DAS models incorporate a bridge located near the stern, providing the crew with a better view aft than forward. This feature lends the DAS a great operational advantage in ice. In the Finnish tanker Lunni, the propulsion system was switched to an azimuth design and the stern was remodeled to an icebreaking form, while the icebreaking bow form remained conventional. In summer 1993 the M/T Lunni inaugurated shipping service with a number of trips to the estuary of the Yana River in Eastern Siberia. The experience of the Lunni clearly demonstrates the feasibility of stern-forward operation in ice. Unfortunately it is not yet possible to guarantee the safety of the DAS under harsh conditions such as steep ice ridges. Research will have to

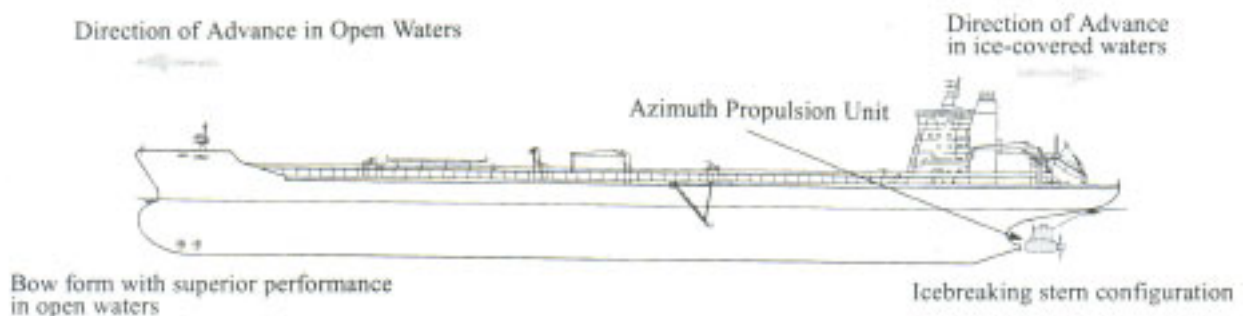

Figure 4.1-15 DAS concept

4. Technological Aspects of NSR Navigation

continue, using mockups and prototypes, to ensure full feasibility of the DAS design and to learn more about its limitations.

Many designs that seem fanciful at first glance, such as the DAS model above, spring from technologies for testing models in ice tanks. The ice tank is an experimental facility used to test a ship's performance under simulated ice conditions. Resources were discovered on the seabed of the Alaskan and Canadian Arctic Ocean in the late 1960s, which prompted dozens of these tanks to be built in the 1970s and 1980s around the world. In general, an ice tank is a towing tank placed in a refrigerated housing; the refrigeration system forms an ice cover in the tank by cooling the room in the insulated housing.



Figure 4.1-16 An overview of a model test in an ice tank

In Figure 4.1-16, an overview of a model test in an ice tank is shown. Most such tanks are long and narrow, used mainly for testing forward motion as in ordinary towing tanks. In Finland, however, a wider tank is also constructed to allow testing of maneuverability.

(2) Research & development of the hull forms for the future NSR vessels

At the SOF, a Research Committee for the NSR was established in tandem with the start of INSROP; at the same time, the SOF established a project, named JANSROP, to develop future NSR vessels and to bring a uniquely Japanese perspective to NSR research in the advancement of the INSROP project, with particular emphasis on the technological aspects of the NSR. Divided into a Phase 1 (1993-1995) and a Phase 2 (1996-1997), JANSROP performed research into icebreaking ships for navigation of shallow, coastal waters in Phase 1 and into vessels with deeper drafts in Phase 2. Through this research program, useful data and information were fully utilized from past R&D projects for icebreaking oil tankers, funded by the Nippon Foundation. Here we see an example of the development of hull forms for icebreaking ships from Phase 1.

The 50,000DWT bulk carrier ("50BC"), as described in the later Section 4.4, is the vessel with deep draft developed in Phase 2, one of the ships tested under the NSR operation simulation project. The research was conducted according to the following study flow.

- Basic design (1993)

Natural conditions along the coastal routes, ports and harbors were surveyed and principal particulars of the candidate vessels were determined. The candidate ships were designed and the ship models were constructed.

- Tank testing (1994)

Using the ship models constructed in the previous year, various model tests were carried out in ordinary towing tanks as well as ice tanks.

- Development and testing of new hull forms (1994, 1995)

The hull form and the models' performance in ice and open water were analyzed through the model test data, which led to the design of new hull forms. The model tests were carried out on the new hull form.

- Overall evaluation (1995)

Overall evaluation of each hull form was carried out with sufficient references to the model test results and

a final design was proposed.

As a result of this basic design work, research focused on development of a ship with the main particulars described in Table 4.1-5. This ship is conceived as a multipurpose icebreaking freighter for navigation of the coastal waters of the NSR (and some inland rivers). The ship is longer than that of the SA-15 class but has a shallower draft, although its displacement will be roughly the same. The design specifications mandated continuous icebreaking capability in 1.2m thick ice at a speed of 3 knots, more powerful than the SA-15s. In terms of the propulsion system, both conventional propellers and duct propellers were tested. To determine the hull form of the ship with these main particulars and obtain definite data on the performance of the ship in ice and open water, three types of bow (A, B and C) and two types of stern (a, b) were designed, and the corresponding models were prepared for testing. Their bow and stern forms are exhibited in Figure 4.1-17. Their features are given below.

- Bow A : Conventional icebreaker bow form with rather simple V-frame lines
- Bow B : Spoon bow with more convex frame lines than A
- Bow C : Bow form with more concave frame lines at the load waterline than A
- Stern a : Mariner stern with moderate U-frame lines
- Stern b : U-frame lines accentuated near the bottom

Model tests were conducted with various combinations of the above bows and sterns.

These combinations are indicated below by letter: for example, a ship that combines bow A with stern a is given the designation A-a. The combinations of the two propulsion systems are indicated CP for conventional propeller and NP for nozzle propeller, so that the designation A-a becomes A-a-CP and A-a-NP).

In the tank tests, the work was divided into two parts: one by NKK Corporation (NKK) and Mitsubishi

Table 4.1-15 Main particulars of the project ship

Length overall	180.0 m
Length between perpendiculars	175.0 m
Width	24.0 m
Depth	16.0 m
Draft	8.0 m
Displacement	25,000 m ³
Hull structure	Double hull, air bubbling system
Number of propellers	1
Propeller	4-blades CPP (Conventional and nozzle propellers)
Performance in ice	Continuous icebreaking capability in 1.2m-thick ice at a speed of 3knots
Performance in calm water	16 knots

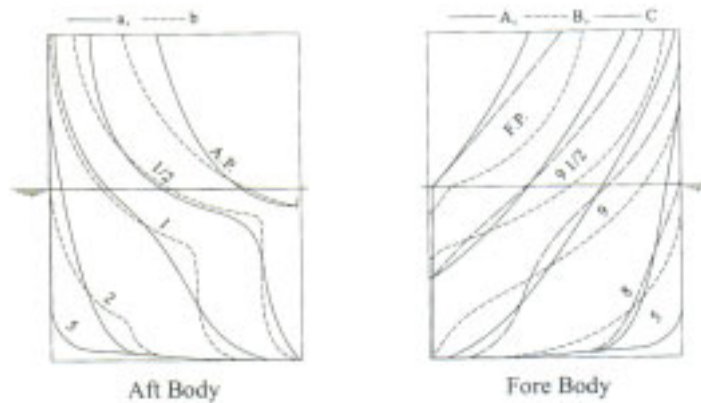

Figure 4.1-17 Bow and stern forms of the project ships

Their bow and stern forms are exhibited in Figure 4.1-17. Their features are given below.



Table 4.1-6 Comparison of ice model basins

	SRI	NKK	MHI
Length, m	35.0	20.0	20.0
Width, m	6.0	6.0	9.0
Water depth, m	1.8	1.8	2.3
Towing speed	0.1 ~ 2.0 m/s	0.005 ~ 1.5 m/s	0.001 ~ 1.0 m/s
Major crystal texture of model ice	Columnar	Fine-grained	Columnar
Dopant	Propylene glycol	Urea	Urea

port, were ies are

4. Technological Aspects of NSR Navigation

- * Turning test in level ice
- * Resistance test in a pressure ridge
- * Self-propulsion test in calm water
- * Manoeuvring test in calm water
- * Self-propulsion test in waves

In the model tests in ice, measurements of Young modulus and flexural strength of the model ice plates were conducted before the ship model tests. In addition to the abovementioned model tests, wake measurements and propeller open-water tests were carried out.

The tests listed above yielded a wealth of data from a wide variety of perspectives on the performance of the various ship types in both ice and open water. The details of these test results appear in appendix 5-1 (an even more detailed treatment is available in Japanese in the JANSROP reports published by the SOF). A typical example of these results is the set of results from the resistance tests in ice (Figure 4.1-18). Because icebreaking resistance depends most crucially on the bow form, the authors have chosen to display data on the combination of stern a with all three types of bow. To verify the effect of the stern, some tests were conducted on the A-b configuration as well, but no significant difference was found with the results for A-a. The results indicated that bow B represents the superior design, exhibiting extremely low resistance. The next-best design was C, followed by the conventional design A, whose resistance was highest.

The model test results of several combinations of bows A, B and C with sterns a and b can be summarized as follows.

- * Self-propulsion test in calm water
- * Bow B offers the best performance in terms of icebreaking resistance.
- * Turning performance in ice is poor for all ship types. That of bow B is particularly poor.
- * Stern b is the best of the two in terms of ice removal from the wake, but stern a is better in terms of propulsion performance.
- * Although no marked difference among bow types was found in terms of propulsive performance in calm water, bow A was the best, followed by B and C.
- * Thrust increase in waves was highest for bow C, followed by A and B.

Taking the above points into consideration and based on the series of test results, new forms of bow and stern were designed and tested. (Figure 4.1-19).

The bow of the new ship type incorporates both the excellent ice resistance qualities of bow B and the superb open-water performance of bow A. This bow form has a stem angle close to 25 degrees (same as bow A) and smaller entrance angle of waterline than bow A; a small fore/buttock line angle near the fore shoulder; knuckle near station 8-1/2; and reamer along the knuckle line. The reamer bulges as much as 5% of the ship's half-width. The reamer and shorter parallel fore capability in ice. To verify the effect of the reamer, the reamer model; when the reamer is fitted the bow is called Dr, and when A new stern "d" was designed to improve turning performance. frame lines between S.S.1/2 and S.S.3 form moderate angles with in stern b was moderated in stern d to get better propulsive performance.

Figure 4.1-19 A new hull form (bow D and stern d)

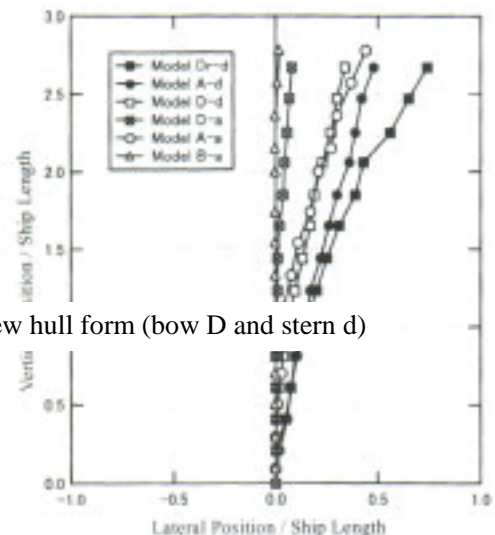
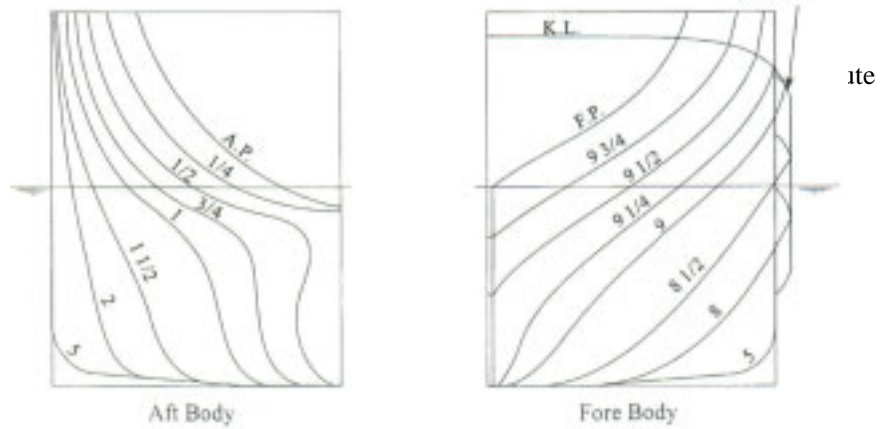

Figure 4.1-20 Results of the turning test in level ice

Four kinds of model tests were conducted on ship forms D-d and Dr-d: Resistance test, self-propulsion test and turning test in level ice, and resistance test in an ice ridge. In addition to these, resistance and self-propulsion



tests were carried out in calm water. As an example, we show here the results of the turning test in level ice (Figure 4.1-20). This illustration compares the results for the new ship forms with those of bows A and B. As the diagram shows, Dr-d, the ship design incorporating the reamer, demonstrates the best turning performance. A comparison between models A-a and A-d clearly shows the effect of the stern form on turning performance. Along with the pronounced effects of the reamer, the short parallel part of the stern d, whose frame lines formed moderate angles with the load waterline, significantly improves the turning performance. Note that the turning performance of previous bows A and C (not shown) are roughly equivalent, while that of B is poorer.

Based on the summarized results of the model tests, each hull form was evaluated. Ideally, the evaluation should have been conducted through a sophisticated numerical simulation as described in Section 4.4, fully utilizing the various performance data for each hull form. Unfortunately, simulations could not be used because the requisite environmental data, particularly the detailed information on ice conditions, were not ready at the time that this research was conducted. Instead, a qualitative evaluation was made for each hull form based on model test results, taking account of the relative importance of each aspect of performance in ice and open water.

The evaluation of the hull form was made for five items based on the test results: propulsion performance

Table 4.1-7 Summary of Hull Form Evaluation

Evaluation item	Weight coefficient	A-a	A-b	B-a	C-a	A-d	B-d	D-a	D-d	Dr-d
Propulsion performance in level ice	8	3	2	5	3	3	5	4	4	4
Turning ability in level ice	4	3	3	2	3	4	2	2	3	5
Ridge-passing capability	4	5	5	5	3	5	5	5	5	5
Propulsion performance in calm water	2	5	5	5	5	5	5	5	5	4
Seakeeping qualities	2	4	4	2	5	4	2	4	4	3
Total evaluation score		74	66	82	68	78	82	78	82	86

in level ice, manoeuvrability in level ice, ridge-passing capability, power requirement in calm water and seakeeping qualities. Each hull form was numerically ranked in performance from 1 to 5 for each evaluation item. The items are weighted with coefficients that reflect the estimated basis of the number of NSR running days in ice-covered water (from the Bering Sea to Kara Strait) and the number of days in open water (from a port in Japan to the Bering Sea and from the Kara Strait to a port in Europe), as well as the priority of each type of performance in operations in ice-covered waters. The highest total score determined the optimum hull form. Nine hull forms (A-a, A-b, B-a, C-a, A-d, B-d, D-a, D-d and Dr-d) were evaluated, and the others that could not be evaluated directly from the test data were estimated by the available data of similar hull forms.

The results of the evaluation are given in Table 4.1-7. Under this evaluation, the hull form with the

4. Technological Aspects of NSR Navigation

highest total evaluation points is Dr-d, reflecting its superior navigational performance in ice. The relatively poor open water performance of the hull form Dr-d was compensated by its excellent performance in ice. It should be noted that this result partially reflects the greater weighting conferred on ice performance in this evaluation. In contrast, for instance, the hull form C-a did well in the open-water evaluation, but its poor performance in ice led to a low total evaluation score.

Based on the above evaluation results, attention was focused on Dr-d as the most appropriate hull form for an icebreaking freighter for the expected requirements of NSR coastal navigation; its performance in ice and open water are summarized in Figure 4.1-21. Given normal rating of 85% of the maximum output of 24,000HP and sea margin of 15%, it is estimated that this vessel will reach speeds of 18.1 knots in open water. In level ice, similarly at 85% of maximum output, the Dr-d ship type is estimated to be capable of continuous icebreaking of ice with 1.2m thickness at a speed of 3.3 knots.

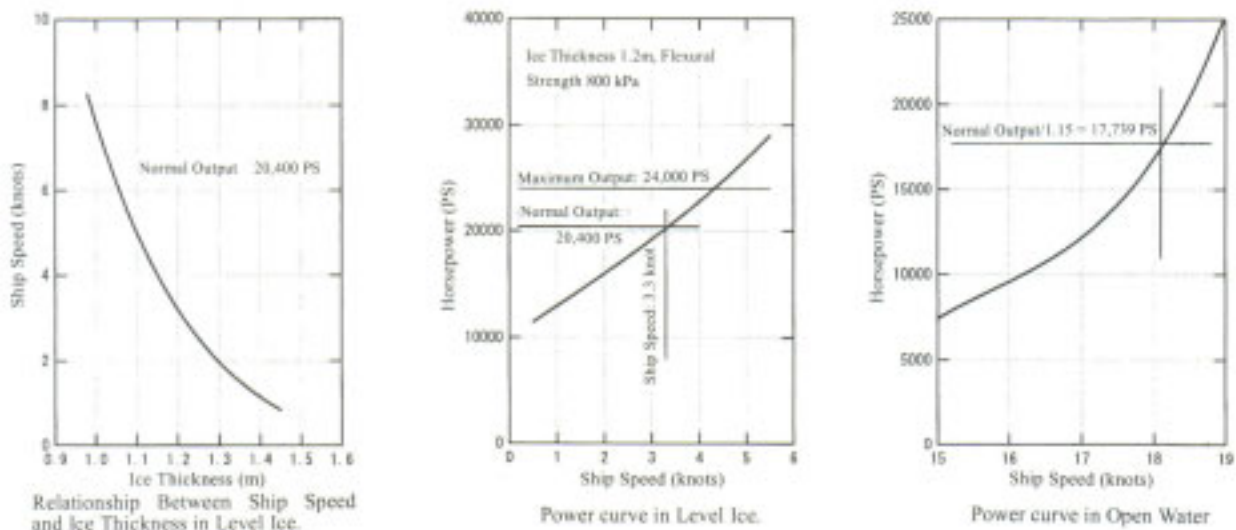

Figure 4.1-21 Performance of the NSR ship optimum for coastal navigation

4.2 Routes and Aids to Navigation

The foremost factors determining the safety and economic feasibility of maritime shipping are the geographical setting, the ship routing and the natural conditions of the route, including both meteorological and oceanographical aspects. The convenience of a given route is also critically affected by the extent of infrastructure providing navigation aids and the availability of systems to provide timely hydrometeorological information for navigation. In this section, we describe the features of the NSR and how the route was selected, then proceed to describe the kinds of infrastructure and information systems that are required to support NSR navigation.

4.2.1 Features of the NSR and Route Selection

(1) Natural environment and geographical setting

The range of the NSR and the seas through which it passes vary with the purposes of operations and activities there. For the purposes of the present discussion, we adopt the Russian administrative definition found in "The Regulations for Navigation on the Seaways of the Northern Sea Route." According to this definition, the NSR is a passage linking Novaya Zemlya with the Bering Strait, which includes, from west to east, the Kara Sea, Laptev Sea, East Siberian Sea and Chukchi Sea. Depending on the context, it may also be taken to include the Barents Sea, which links these seas with the North Atlantic Ocean.

Obviously the most salient difference between the NSR and other sea lanes is the harshness of its natural environment. Ships traversing the NSR must cross numerous seas in the freezing Arctic environment, facing problems not encountered in other sea lanes. In this extremely cold environment, ice quickly accretes onto ship hulls and fittings, the job performance of crews deteriorates, steel toughness decreases, water and other liquids inside pipes freezes, some cargoes have to be insulated. Besides the direct problem of low temperatures are other issues relating to the high latitudes of the NSR. Passing through the Arctic night, NSR vessels suffer from poor visibility. Proximity to magnetic north renders the use of compasses difficult. Because satellite communication does not provide adequate coverage, sea-to-land communications are often blocked or unreliable. In sum, the extreme cold and high latitudes of the NSR create a uniquely difficult environment for shipping. The biggest problem, however, is the presence of ice. The ice conditions in the NSR are discussed in section (2) below.

Though climatic and hydrological conditions change dramatically in the NSR from sea to sea and from season to season, the route can be broadly divided into an eastern, a central and a western section. Various features distinguish these sections as follows.

* Western (from the Barents Sea to the western Kara Sea)

This section is relatively warm, under the influence of the Gulf Stream. The Barents Sea in particular is almost completely free of ice even in the harshest winter. For this reason, Murmansk is an ice-free port.

* Central (from the eastern Kara Sea through the Laptev Sea to the western East Siberian Sea)

This region is extremely cold, due to the influence of the continental climate, cold water and ice fields of the North Pole, where a huge volume of freshwater inflows from large rivers stimulates the formation of sea ice.

* Eastern (from the eastern East Siberian Sea to the Chukchi Sea)

Sea ice formation is moderate in this region compared to the central region, due to the warming influence of ocean water flowing in from the North Pacific Ocean.

Other central features of NSR navigation concern the geography of the NSR. Many islands obstruct the route from west to east, such as Novaya Zemlya, Severnaya Zemlya, the New Siberian Islands and Wrangel Island. The route passes through a series of straits that form either between islands and the continent or between islands (Figure 4.2-1). Many of these straits are both narrow and shallow, forming a significant geographical constraint to navigation along the NSR. The following is a list of the major straits and their important characteristics.

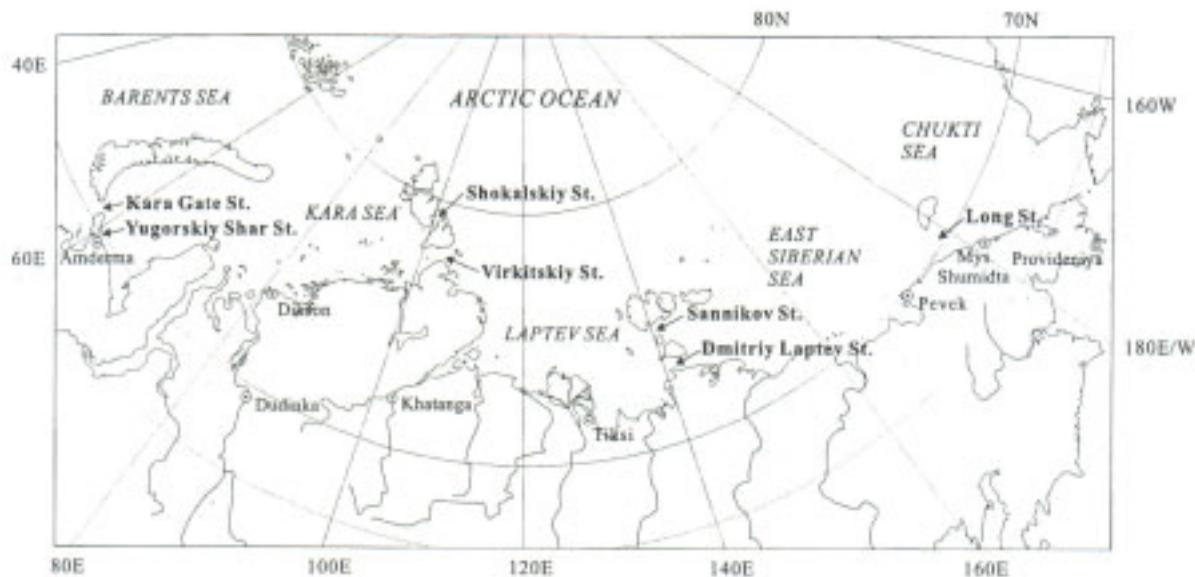

Figure 4.2-1 Major straits in the NSR

* Yugorskiy Shar Strait

Yugorskiy Shar Strait is located along the south coast of Vaygach Island and is the southernmost entrance from the Barents Sea to the Kara Sea. The strait is 21 NM (nautical mile) in length and 5.5 NM wide at its narrowest, with depths ranging from 13–15 m in the west to 16–30m in the east.

* Kara Gate Strait

Forming the gap between Novaya Zemlya and Vaygachi Island, the Kara Gate Strait is the main shipping strait between the Barents and Kara Seas. The 18NM-long strait has a minimum depth of 21m. A traffic separation scheme is in place in this narrow shipping lane.

* Vilkitskiy Strait

This strait separates Severnaya Zemlya from the northernmost extremity of the Eurasian continent, Cape Chelyuskin. Although ships of any size and draft can make passage, the eastern and western approaches to this strait can be clogged with ice fields, depending on the wind direction. When these conditions prevail, icebreaker escort can often be difficult.

* Shokalskiy Strait

Shokalskiy Strait is located in Severnaya Zemlya, north of the Vilkitskiy Strait. The strait, 80NM long and 10NM wide at its narrowest point, has a minimum depth of 37m. The width and depth do not pose a limiting factor for any ship. However, ice conditions in this strait are generally less favorable than in the Vilkitskiy strait.

* Dmitry Laptev Strait

This strait is the southernmost passage between the New Siberian Islands and the mainland, linking the Laptev and East Siberian Seas. It is 63NM long and 30 NM wide. The strait has depths of 12–15m in a band of 14–18 NM along the axis, oriented east-west. The eastern approach, however, has shallow water with less than 10m depths, restricting traffic to ships with less than 6.7m draft.

* Sannikov Strait

Sannikov Strait is a second passageway through the New Siberian Islands (Novosirskiye Is.) linking the Laptev and East Siberian Seas. The strait is approximately 160NM long, with a fairway width of 16–18 NM, whose minimum depths are more than 13m. The low surrounding islands make visual and radar navigation difficult. Stable fast ice covers the strait from the end of autumn to the beginning of summer. In some unfavorable years, the strait remains icebound year round.

* Long Strait

Long Strait separates Wrangel Island from the mainland, linking the East Siberian and Chukchi Seas. This strait consists of two passages through the wide channel, a 120NM southern passage with 20m minimum depths and a 160NM northern passage with 33m minimum depths, both of which are navigable. In winter the fast ice extends from the mainland to Wrangel Island, but it always recedes by the summer. However, the passages tend to remain clogged with ice massifs or multi-year ice.

Of these straits, an icebreaker escort is required for the navigation of Vilkitskiy Strait, Dmitry Laptev Strait, Shokalskiy Strait and Sannikov Strait.

(2) Ice conditions

Undoubtedly the presence of sea ice constitutes the critical factor in NSR navigation. NSR operations require the use of icebreakers and other ice-worthy ships, and in practice the routes taken through the NSR depend crucially on the condition of the ice. Ice conditions vary greatly from region to region and from season to season in the NSR. In the following section, we look at ice conditions in summer and winter. Rather than follow the traditional divisions of the four seasons, we will distinguish only between winter, defined as the period from October to May when the sea ice grows, and summer, defined as the period from June to September when the sea ice thaws. To view the differences in ice conditions from region to region, in Figure 4.2-2 we divide the NSR into seven regions from the Kara Sea to the Bering Strait (WP-121).

- * Southwestern Kara Sea
- * Northeastern Kara Sea

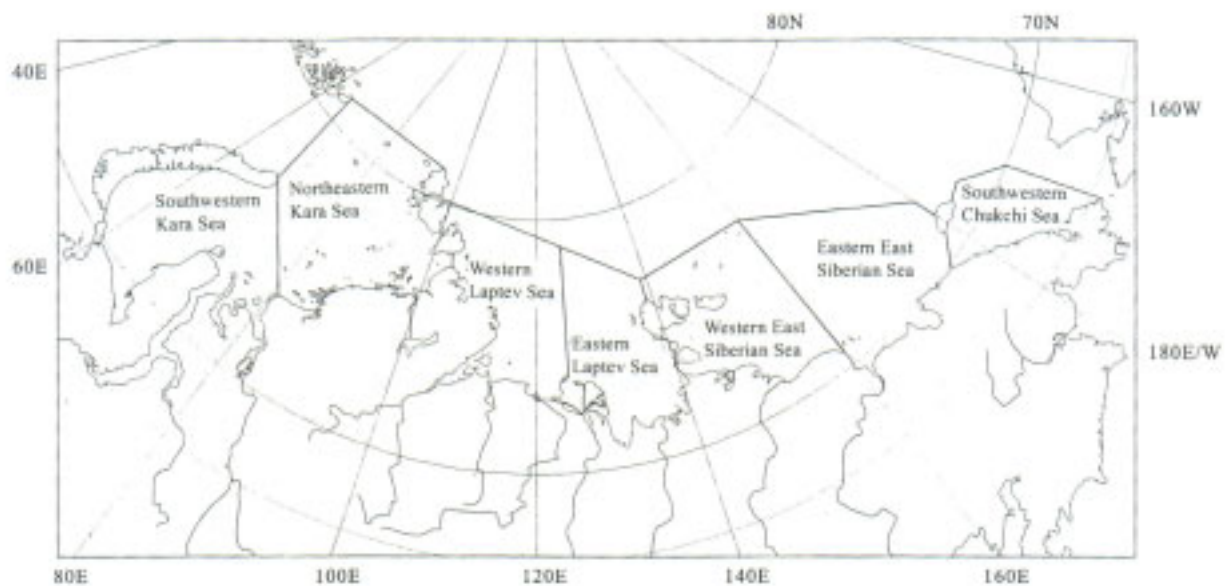

Figure 4.2-2 Ice-region boundaries for the Russian maritime Arctic

- * Western Laptev Sea
- * Eastern Laptev Sea
- * Western East Siberian Sea
- * Eastern East Siberian Sea
- * Southwestern Chukchi Sea



Figure 4.2-3 Fast ice

Due to offshore archipelagos and shallow shelves along the NSR, extensive landfast ice is always present in the region in winter. The fast ice grows out from the mainland or islands into the sea, and can attain thicknesses of over 2m. In two key regions the fast-ice boundary extends extraordinary distances from the mainland. In the first, the landfast ice boundary usually extends from the eastern Kara Sea to the northern extremity of Severnaya Zemlya. The second region is a fast-ice region surrounding the New Siberian Islands, located far from the mainland (Figure 4.2-3). As described in Chapter 3, the formation of fast ice is governed by marine geography: In these regions shallow continental shelves extend far out to sea, and are fed with fresh water by large river systems such as the Ob, Yenisey and Lena. The inflow of a large volume of fresh water generates a surface water layer of a low salinity that facilitates the growth of sea ice. Conversely, the seas from the Chukchi Sea to the eastern East Siberian Sea lack these features and receive a warm ocean current from the North Pacific Ocean, limiting the formation of fast ice to narrow coastal bands.

The polynyas are found in all regions of the Russian Arctic. Flaw polynyas created by prevailing offshore winds are dominant features of sea ice along the outer edges of the fast ice, between the fast ice and drifting ice in the adjacent open seas (Figure 4.2-3). The flaw polynyas are often used as passageways for NSR navigation. In the Barents Sea, a large area exists where no ice is found, due to the warming influence of the Gulf Stream.

As the sea ice expands, the thickness of the ice becomes the key parameter affecting navigation. Generally, first-year ice begins growing at the beginning of the winter, and as the months progress its speed of growth declines, so that it reaches its maximum extent at the end of the winter. Figure 4.2-4 illustrates the growth of first-year ice. In this figure, the ice thicknesses at the end of each month are calculated from the growth rate of level ice in each region. Naturally the growth rate is different in each region. In the eastern Laptev Sea and western East Siberian Sea in the middle of the NSR, sea ice grows fastest, reaching a thickness of over 2m at the end of May. At both the eastern and western sides of the NSR, ice growth is relatively moderate.

The fast ice that grows in the winter generally thaws in the summer, causing its extent to shrink. Figure 4.2-5 shows the summertime changes in the extent of open water in each region. The open water area continues to grow throughout the summer. Unfortunately, none of the regions becomes completely free of ice, shattering expectations of easy NSR operations during the summer. The extent of open water varies widely from sea to sea. In particular, the northeast Kara Sea and the East Siberian Sea have no open water at the end of June and remain extensively covered by ice even at the end of September. By contrast, however, the southwest Kara Sea and southwest Chukchi Sea, adjoining those harsh regions on the east and west sides respectively, display a marked increase in open water during the summer, so that scarcely any ice remains at the end of the summer.

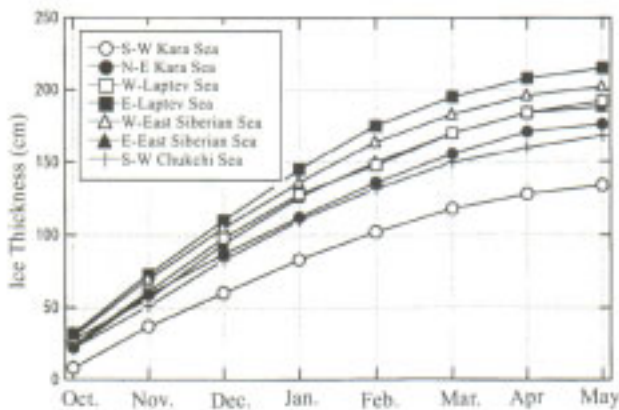

Figure 4.2-4 Growth of sea ice in winter

The presence of ice massifs, together with the differences in climate and the effects of inflows of warm currents from the Atlantic and Pacific Oceans as described earlier, result in marked variation in ice coverage among the various seas. As discussed in Chapter 3, ice massifs are found in certain regions even in the summer thawing period. A comparison of the ice massifs map in Section 3.2.3 with Figure 4.2-5 reveals that the areas of little open water—the eastern Kara Sea, western Laptev Sea and East Siberian Sea—are those possessing ice massifs (respectively, the Severnaya Zemlya, Taymyr and Ion Ice Massifs). As the following section explains, NSR navigation is charted so as to avoid these ice massifs.

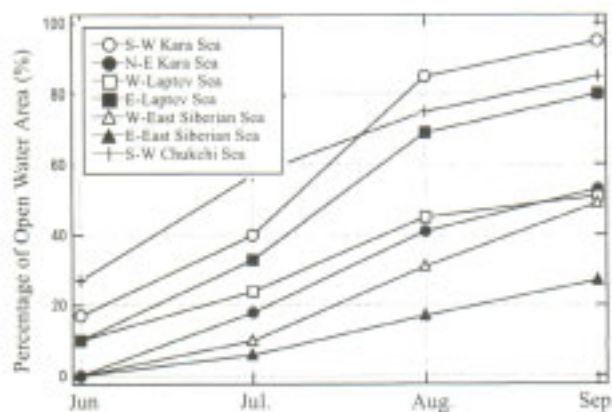

Figure 4.2-5 Expansion of open water in summer

(3) Route selection

Clearly, as the foregoing discussion illustrates, the route through which the NSR passes is strongly affected by its natural conditions. Of all of the natural conditions with impact on the selection of the routes, the depth of the water along the routes is the primary factor. Because the NSR consists entirely of continental shelf, a major portion of the passage and especially its straits are extremely shallow. Shoals no deeper than 20m are by no means rare, raising the danger that deep-draft ships may run aground on them. The second key factor in selection of a route is the condition of the ice. The sea ice in the NSR is grueling, with large ice fields often remaining even in summer. Under these extreme conditions, at times the ice may prevent passage of ships or cause damage to hulls and propulsion systems. For this reason, NSR ships are often forced to detour to avoid the harsh ice. To ensure safe passage through the severe Arctic ice, ships traveling through the NSR should request instructions for their routes from an agency named Marine Operations Headquarters (MOH). MOH decides a route of a ship traveling through the NSR, taking account of both present and foreseen ice conditions as well as the ship's draft with respect to water depth, and informs the route to the ship. MOH is a supervisory body responsible for all aspects of navigation in the NSR, with operations split between two headquarters east and west, at Pevek and Dikson. Their areas of authority are divided at



Figure 4.2-8 Routes selected by CNIIMF

Figure 4.2-7 Recommended route in winter

Various routes have been proposed in the course of INSROP Phase II, which is discussed in Section 4.4. The INSROP routes were based on a comparison of the economic performance of several routes in a simulation of voyages from Europe to Japan through the NSR (WP-164). The data on water depths and other key items for the simulations were gathered into segments set by CNIIMF at intervals of 20NM along a selected route through the NSR from Hamburg to Yokohama (Figure 4.2-8) (WP-108). The simulation focused on two types of NSR vessel, one a ship with moderate size and shallow draft, which was to follow the coastline, and the other a large vessel with a deep draft, traveling far offshore from the continent and islands. Two routes were thus selected, a coastal or "southern route" and an offshore or "northern route." Moreover, a further distinction was made in the southern route between a "western route" and an "eastern route," with the former traveling from Hamburg to a position off the port of Dikson, linking the Russian Arctic with Western Europe, and the latter tracing a path from a position off the port of Tiksi to Yokohama, to link the Russian Arctic with Japan. One of the objectives of the simulation for the two types of ships in different routes was to determine the most appropriate type of NSR ship. It was also expected that this simulation would provide useful information on optimum scheduling and routing, based on the natural

conditions and the season of operation. The depth data from this study highlights the differences in depth between the two routes (Figure 4.2-9), offering a clear illustration of the problems of shallow waters along the Russian coast as discussed above. As the illustration makes clear, the eastern NSR is a continuous stretch of shallow water-especially along the coast of the mainland, where depths of a mere 20m are common.

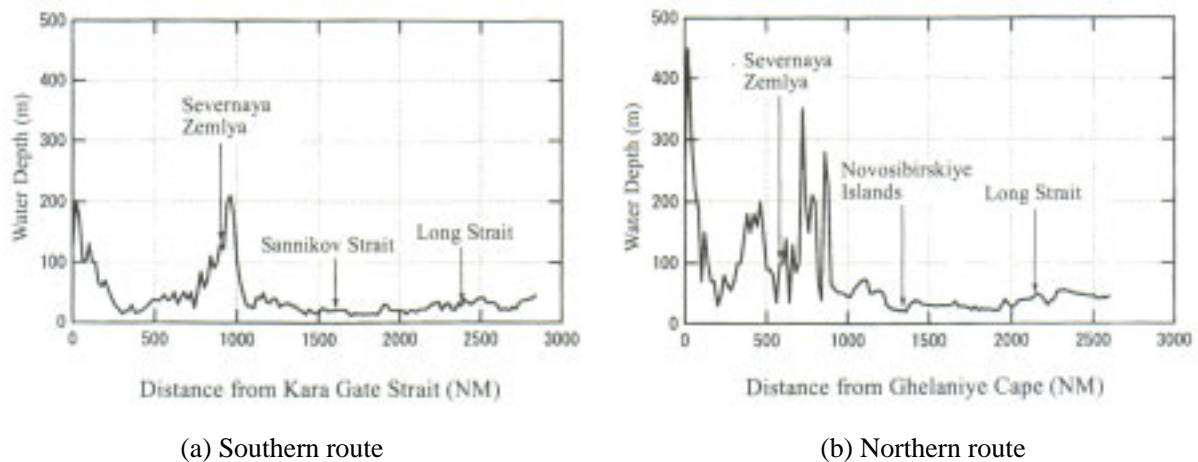

Figure 4.2-9 Differences in depth among the routes selected by CNIIMF

4.2.2 Aids to Navigation

(1) Infrastructures for aids to navigation

As explained in the previous section, the NSR is replete with hazards such as shallows and unseen rocks. In addition, a considerable volume of traffic links river traffic along the Ob and Yenisey Rivers with the NSR. These hazardous locations and areas of high traffic require the installation of various navigational aids at important waypoints, including radio beacons, unlit marks or day beacons, lighted marks, racons (radar beacons), radar reflectors and various buoys. Today, satellite-based ship position-finding systems are common and indispensable tools for navigation, and are as valuable in the NSR as in other shipping lanes.

Radio beacons are currently installed in 47 locations throughout the NSR, seventeen of which are manned stations. Two types of radio beacon are in use, one with a range of 100NM and the other with a range of 150NM; a new beacon with 300NM range is currently under development. At the same time, 30 locations mostly in the estuaries are outfitted with racons. A further 200 radar reflectors are also dotted along the coast. The reflectors are installed because the low, surrounding islands make radar navigation difficult. In many cases unlit or lighted marks are attached to the racons. Including this number of racons with marks, NR boasts some 250 lighted marks and 200 unlit marks. In the summer, some 1,000 floating marks are added.

The Global Positioning System (GPS) is a system for determining the precise location of objects using satellite data. Today this information is used not only by ships but by aircraft and even by automobiles, and GPS is a valuable system for ship positioning in the NSR as well. A similar system called GLONAS is used with Russian satellites, but in practice only Russian ships are outfitted with the electronic devices necessary to receive GLONAS signals. The GPS system, which was originally developed for military applications, is provided to civilian users with the capability to determine positions within at least 100m with 95% accuracy. To obtain more precise positioning, the DGPS mode was developed, in which the positioning data at land stations is compared with the data received by the ship to yield resolution as fine as 10m. In the NSR, DGPS land stations are planned for four locations to cover the Kara Sea: Oleny, Sterligov, Yugorskiy Shar and Lipatnikovo. The information gleaned from these land stations is used not only to ensure the safe passage of vessels through hazardous areas such as the Kara Gate Strait, but also to serve purposes such as

4. Technological Aspects of NSR Navigation

oceanographic research and resource exploration and development.

The above information on various marks and satellite ship positioning systems is based on an INSROP research report (WP-108). This report can be thought of as a compilation of information as of 1998, but it should be borne in mind that many of these navigation aids may no longer be available for use, due to the recent economic upheavals in Russia. For example, no reliable data is available on the state of repair or replacement of various marks, so these navigation aids may no longer be functional, particularly in the eastern NSR. Moreover, the plans for DGPS land stations were in the testing phase in 1998, and no new information on their implementation is forthcoming.

(2) Ports

The NSR is a direct sea route linking the Atlantic and Pacific Oceans, as opposed to the roundabout southern route through the Suez Canal. It links the cities of northern Russia to the cities of Europe, Japan and North America, and serves as an inter-city route in northern Russia. In this sense the ports along the NSR have a critical role to play in its success. These ports are of great value in providing this shipping route with provisions, emergency repairs and rescue operations. With this in mind, the approximate distances between primary ports and positions on the NSR and adjacent waters are summarized in Table 4.2-1.

Table 4.2-1 Distances between ports and positions on the NSR and adjacent waters

Location	Tomso	Murmansk	Arkhangelsk	Yugorskiy Shar Strait	Kara Gate Strait	Matochkin Strait	Ghelaniye Cape	Dikson	Dudinka	Igarka	Vilkitskiy Strait	Khatanga	Tiksi	Sannikov Strait	Dmitry Laptev Strait	Pevek	Bering Strait	Provideniya	Dutch Harbor	Valdez	Vancouver	Vladivostok	
Murmansk	407																						
Arkhangelsk	772	435																					
Yugorskiy Shar Strait	848	578	659																				
Kara Gate Strait	799	523	607	65																			
Matochkin Strait	678	466	617	320	260																		
Ghelaniye Cape	905	745	920	650	590	330																	
Dikson	1,289	1,013	1,097	477	490	461	310																
Dudinka	1,619	1,343	1,429	807	820	791	640	330															
Igarka	1,715	1,439	1,523	903	916	887	736	426	136														
Vilkitskiy Strait	1,686	1,410	1,491	874	887	858	521	496	826	922													
Khatanga	2,234	1,958	2,039	1,422	1,435	1,406	1,069	1,044	1,324	1,470	548												
Tiksi	2,321	2,045	2,126	1,509	1,522	1,493	1,156	1,131	1,461	1,557	635	786											
Sannikov Strait	2,285	2,009	2,090	1,473	1,486	1,457	1,120	1,095	1,425	1,521	599	770	325										
Dmitry Laptev Strait	2,288	2,012	2,093	1,476	1,489	1,660	1,130	1,098	1,428	1,524	602	773	210	93									
Pevek	2,864	2,588	2,660	2,052	2,065	2,036	1,699	1,674	2,004	2,100	1,178	1,349	819	579	609								
Bering Strait	3,850	3,074	3,155	2,538	2,551	2,522	2,185	2,160	2,490	2,586	1,664	1,838	1,390	1,065	1,110	558							
Provideniya	3,460	3,184	3,265	2,648	2,661	2,632	2,295	2,270	2,600	2,696	1,774	1,948	1,508	1,175	1,220	668	110						
Dutch Harbor	4,150	3,871	3,955	3,338	3,351	3,322	2,985	2,960	3,290	3,386	2,464	2,638	2,190	1,865	1,910	1,258	690	615					
Valdez	4,955	4,679	4,760	4,143	4,156	4,127	3,790	3,765	4,095	4,191	3,269	3,443	2,995	2,670	2,715	2,063	1,495	1,420	805				
Vancouver	5,682	5,406	5,487	4,870	4,883	4,854	4,527	4,492	4,822	4,918	3,996	4,170	4,080	3,755	3,800	3,248	2,332	2,241	1,626	1,210			
Vladivostok	5,885	5,609	5,690	5,073	5,086	5,057	4,720	4,695	5,026	5,121	4,199	4,373	3,925	3,600	3,645	3,093	2,535	2,425	1,880	2,680	4,278		
Yokohama	6,043	5,767	5,848	5,231	5,244	5,215	4,878	4,853	5,183	5,279	4,357	4,531	4,441	4,116	4,161	3,609	2,693	2,583	2,580	3,380	4,258	931	

The arrival of foreign vessels at ports along the NSR is restricted by the Russian government. At the beginning of each year, the Russian government posts a "Notice to Mariners" listing the ports that are open to foreign ships in that year. In 1997, for example, the ports of Igarka, Dikson, Tiksi and Pevek were declared open; in the following year, Amderma, Yamburg, Dudinka, Khatanga, Zelenyy Mys and Provideniya were added to the list for a total of 10 open ports. It is difficult to forecast whether these ports will remain open in

the future or whether new ports will be added, as these questions depend on federal and local government policies. Unfortunately, many of the ports that have been opened do not meet the requirements of an international port. Below we provide a brief overview of each of the ports open in 1998.

* Amderma

Located in the southern Kara Sea near the Yugorskiy Shar Strait. Vessels may be unloaded only on the roadstead. Amderma has an airport, hospital, postal service, telegraph and telephone line. Fuel and other provisions are available only in exceptional cases.

* Dikson

This port is situated in the southeastern Kara Sea near the entrance to the Gulf of Yenisey. Vessels with maximum permitted draft of 11m may enter. Lifting capability of the port's unloading equipment is maximum 8t. The port has an airport, hospital, radio relay line to Dudinka and radio aids to navigation. Fresh water and minor repairs can be obtained. A rescue team and a radio navigational equipment repair group are based in Dickson.

* Yamburg

Yamburg is a recently built port at the mouth of the River Nude-Mongotoepoko in the Ob Gulf. A channel with a depth of 5.5m leads to the port. The port is equipped with floating and motor cranes, and hospital facilities are available.

* Dudinka

Located 231 miles upstream from the mouth of the Yenisey River, Dudinka is serving the requirements of the Norilsk industrial complex. The roadstead is 40m deep, and up to ten ships may berth at the same time. The port is equipped with gantry cranes, tug assistance, diving assistance and repair facilities. Fresh water taken from the river in accordance with the instructions by medical authorities and other provisions can be obtained here. In the nearby city of Norilsk, an airport, hospital, postal service, telegraph and telephone line can be found.

* Igarka

Igarka is situated 370 miles south of the mouth of the Yenisey River. Depths alongside berths are 10-11m and the port is equipped with gantry and floating cranes. Minor repairs are available, and fresh water may be taken from the river. Hospital and postal facilities are available and an airport is located 1.5km away.

* Khatanga

This port is situated 115 miles from the mouth of the Khatanga River. Pilotage is provided by pilots of Khatanga Hydrobase. Depths in the port are 3.5-8m, and the port is equipped with 3-8t gantry cranes and one floating crane. Tug assistance is available. Minor repairs can be performed here and a hospital, postal service and airport facilities are available.

* Tiksi

Tiksi, the largest port on the NSR, is located in the southern Laptev Sea near the mouth of the Lena River. Depths in the port are 5.4-10m and the port is equipped with a 25t gantry crane. Repair facilities, bunkers and other provisions are available. The Hydrobase provides diving service, repairs of navigational equipment and navigational information. Floating cranes and tug assistance are available, as are a hospital, postal service, telegram, telephone line and airport facilities.

* Zelenyy Mys

Zelenyy Mys is a port on the Kolyma River. Pilotage to the port is compulsory. The port is equipped for roadstead discharge. Medical assistance and postal service are available. Bus service is available to the airport at Chersky.

4. Technological Aspects of NSR Navigation

* Pevek

The port of Pevek is near the town of Pevek, administrative center of the Chaunsky Region of the Chukotka. A hospital, postal service and bank as well as an airport are available in Pevek.

* Provideniya

Provideniya is located on Provideniya Bay on the Chukotka Peninsula. Overall depths in the bay are 30–35m and 9m near the berths. Medical and tug assistance are available and navigational information can be obtained from the Provideniya Hydrobase.

The port information provided above is derived from an INSROP survey (WP-17). Continuous change in the Russian Arctic makes the functions of the ports and even their availability to foreign ships unpredictable.

(3) Radio Communication

A radio communication system is installed in the NSR for use in ship traffic control and broadcasting information on ice conditions and the like. This system is divided at longitude 125 ° E into two broad zones nationwide. In the west, communication centers are established at Murmansk, Dikson and Amderma; in the east, they are located in Tiksi, Pevek and Mys Shmidta. All ships navigating the NSR are required to maintain close contact with the MOH and escort icebreakers using the medium-frequency (MF) range, to report ship locations regularly and receive route instructions. In addition to the conventional radio communication equipment specified in international conventions, vessels on the NSR should be equipped with VHF radio equipment (122.5MHz) to communicate with aircraft and convoy ships, equipment for sound recording and reception of facsimiles, and a satellite communication station.

Radio communications may from time to time be adversely affected by magnetic storms, which recur in cycles of 25 to 30 days. A single magnetic storm usually lasts for a few hours, but may occasionally interfere with radio communications for over a day. Magnetic storms are most powerful in the regions where the aurora is seen, and particularly in a band from 72 ° to 74 ° N off the north coast of Novaya Zemlya, as well as the north coast of Severnaya Zemlya and at the mouths of the Ob and Yenisey Rivers.

Different types of radio communication are used for different ranges and purposes. Radio communications are used at relatively short distances, as in ship-to-ship, ship-to-airport or ship-to-shore communication. For more long-distance communication, such as communication between ships navigating different regions and communication between the ship and its country of registration, satellite communications are used. Two systems* for satellite communications are in use in the NSR: an international standard system and a Russian system. The international system is the INMARSAT satellite system and the Russian proprietary system is called OKEAN.

The INMARSAT system covers the NSR area with two geostationary satellites, IOR at east longitude 64 ° over the Indian Ocean and POR at east longitude 178 ° over the Pacific Ocean. However, because the NSR passes through high latitudes, these satellites sit low above the horizon, rendering communications difficult in some areas (Figure 4.2-10). Outside the curve of 0 ° elevation above the horizon, the satellite is hidden below the horizon, rendering communication theoretically impossible. In the western Laptev Sea, which lies at a high latitude of about 120 °, both IOR and POR sink below the horizon, placing this area beyond the reach of INMARSAT communications. Even in regions where the satellite's angle of elevation is above 0 °, ship superstructures, deck machinery and appliances may cast a shadow on satellite antenna, adversely influencing the ability to receive signals and obliging the ship's crew to remedy the situation by turning and retrying communication.

Russia's OKEAN network, on the other hand, covers the NSR with three satellites, one hovering over the

Atlantic Ocean at 40° E longitude, a second over the Indian Ocean at 80° E and a third over the Pacific Ocean at 140° E. The Russian system covers the entire NSR, with at least one of these three satellites above

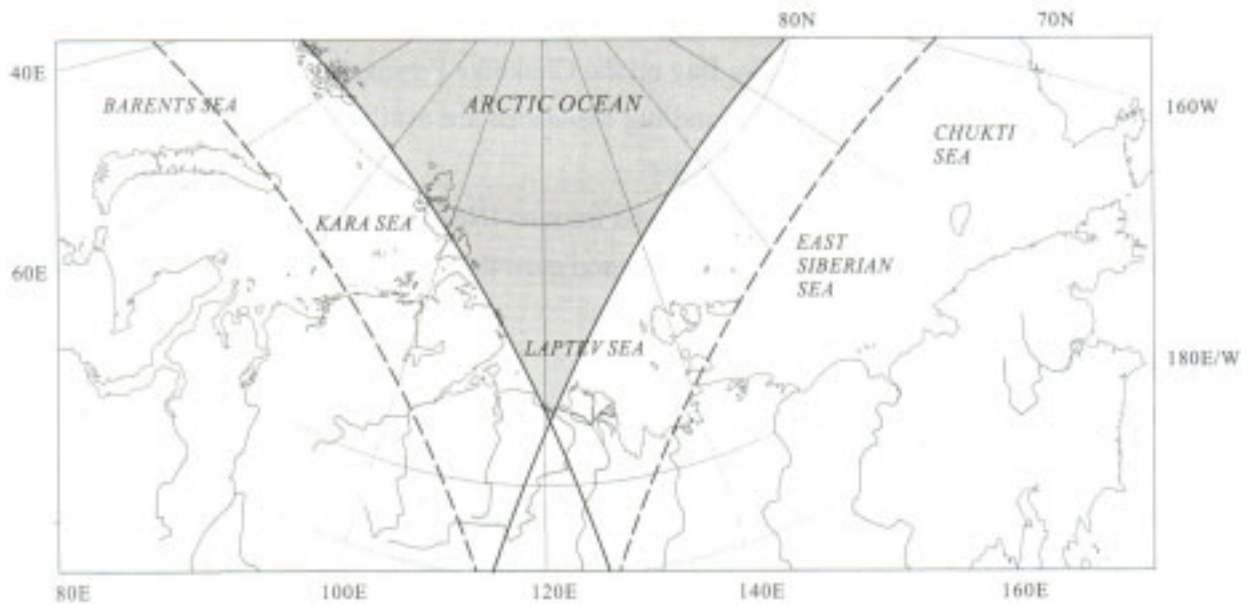

Figure 4.2-10 INMARSAT communication coverage at 5 and 0 elevations

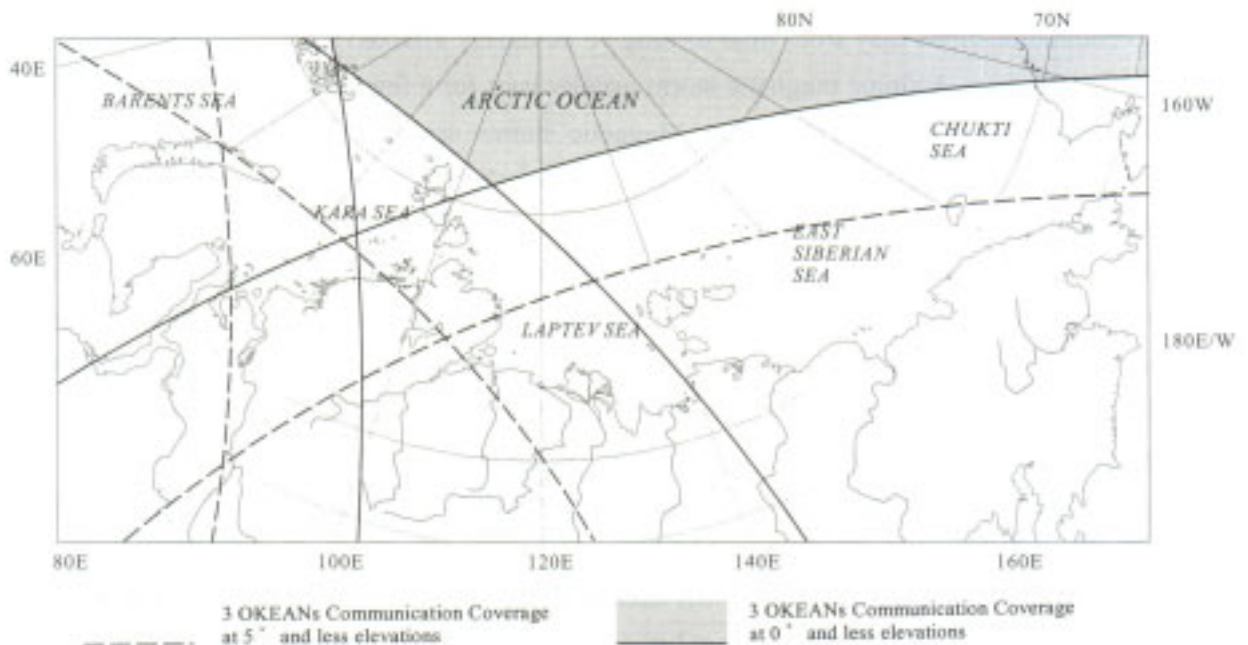

Figure 4.2-11 OKEAN communication coverage at 5° the horizon at all times (Figure 4.2-11). Few of the INMARSAT ship receivers are compatible with the OKEAN system and unfortunately only a few devices are capable of the OKEAN system; Russia's Volna-C and Iceberg, Norway's Saturn-3C and Japan's JUE-45. None of these devices is widely used.

(4) Sea ice and meteorological data

This report has repeatedly stressed the harshness of the natural environment of the NSR, particularly its sea ice, and the need for constant and reliable data to ensure the safety of ships traveling in the area. To

4. Technological Aspects of NSR Navigation

provide this information, the AARI (Arctic and Antarctic Research Institute) Center for Ice and Hydrometeorological Information (CIHMI) in St. Petersburg, within the Federal Service for Hydrometeorology, has devised and implemented a system to gather data about the meteorological and ice conditions in the NSR and provide analyses and forecasts to those who need them. CIHMI is also linked in a network to regional centers along the NSR coast, in Dikson, Tiksi and Pevek.

Sea ice and meteorological information has been gathered and analyzed from a broad range of source data. Surface-based observation data are gathered from icebreakers and other vessels traversing the NSR as well as from land-based and drifting autonomous observation stations throughout the Arctic Ocean. The data from these autonomous stations are sent to CIHMI through the OKEAN satellites. Aerial and space observations consist of remote sensing data from satellites and reconnaissance by airplanes. Satellite data is gathered not only by Russia's OKEAN

*A new commercial system called IRIDIUM, developed by Motorola, can offer telephone communication to any point on Earth. A constellation of 66 polar-orbiting satellites in a low 760 km orbit altitude can provide voice communication anywhere, but not data transfer.

and METEOR satellites but by NOAA satellites as well, relaying images to land-based stations in the visible-light, infrared and microwave ranges. Visual observations are gleaned from aircraft as well as through monitoring by side-looking radar.

Needless to say, Russia's automated ice/hydrometeorological information-gathering system did not appear overnight. The quality and quantity of the observation data they gathered increased over time in tandem with technological progress. Regular observations from aircraft began in 1941-1942. Although originally only visual observations were conducted, after the introduction of side-looking radar in 1968 it became possible to perform year-round base observations. The era of satellite data began in 1969 with the reception of visual-light range images from the Meteor-1 satellite series. In 1975 the Soviets launched the Meteor-2 satellite series which carried sensing systems for infrared range in addition to visual-light range. The successor to these satellites, the Meteor-3 series, was launched in 1987 and is still in use today, and in 1983 the OKEAN-1 series was launched, loaded with side-looking radar, microwave radiometer and visible-light sensors.

As this monitoring technology, particularly satellite monitoring, advanced in sophistication, the systems used to gather and deliver data on ice and sea conditions in the NSR evolved with it. Before remote-sensing data from satellites came into extensive use, information was gathered and analyzed at regional centers in Dikson, Pevek and other northern port cities. Each of these centers used the data to provide short-term (about one week) forecasts of ice and weather conditions, provide ship traffic control stations with ice maps and to provide advice to crews navigating the NSR. The information from each center was sent to CIHMI, where the data was tabulated to produce ice maps for the entire NSR and medium-to-long-term forecasts (from two or three months to a year) of ice and weather conditions, which it then forwarded to ship traffic control stations. As both the quality and quantity of the data gleaned from satellites improved, however, the limitations of the regional centers in processing this satellite data became apparent, and the case for maintaining these regional centers weakened. Presently sea ice and meteorological data are handled centrally at CIHMI, which prepares short-term ice forecasts and ice maps and provides a variety of information to ship traffic control stations and other users of the data.

(5) Technology for satellite monitoring of sea ice conditions

Information on sea ice conditions is essential for NSR navigation and northern navigation in general.

Unfortunately the number of observation stations and aircraft, ships and so forth used for observation is limited. Moreover the brutal natural conditions make local observation and measurement difficult in many cases. Recently, however, significant progress has been made in technologies for the observation of the earth's surface, enabling satellite imaging to be applied to monitoring of ice conditions. As stated earlier, the monitoring of sea ice conditions through satellite images is one of the key tools used for ice-condition forecasting in the NSR.

A wide variety of sensors are installed in satellites, each corresponding to different electromagnetic frequency bands and observational objectives. In observing sea ice conditions to provide ships with navigational support, today the most promising frequency band seems to be in microwave range. This is because microwave radiation can display conditions on the earth's surface regardless of whether skies are clear or cloudy, and can thus be used in all weather and throughout the Arctic night. Microwave sensors can be broadly divided into two groups: passive sensors and active sensors. Passive sensors pick up microwave radiations from the earth's surface and form an image; the principles by which they work and their methods of operation are rather simple. Active microwave sensors radiate microwaves from a satellite at a particular region of the earth's surface; an image is formed by the satellite as it picks up the scattered reflections. A prime example of an active microwave sensor is the Special Sensor Microwave Imager (SSM/I) used in the DMSP program in the United States. Active-type examples include the microwave scanning radiometer (MSR) installed in many satellites, such as MOS, NIMBUS and NOAA; the Scanning Multichannel Microwave Radiometer (SMMR); and the side-looking radar on Russia's OKEAN. Another type of active microwave sensor is the Synthetic Aperture Radar (SAR). Boasting an extremely high resolution of 100m, this sensor is expected to prove highly valuable in monitoring of ice conditions.

Microwave remote-sensing systems such as SAR are valuable tools for monitoring ice conditions, and indeed are used extensively by Russia to assess ice conditions in the NSR as discussed above. After the NSR was opened, several test voyages were conducted, making extensive use of satellite data to determine their actual routes. The first non-Russian vessel to traverse the NSR completely after the route was opened was L'Astrolabe, which used sea ice maps produced from SAR and SSM/I images obtained from ERS-1 and faxed directly to the ship (Johanssen, 1992). This approach was also followed in a test voyage by the Kandalaksh, organized by the SOF. In the case of the Kandalaksh, however, the SAR data was sent not by facsimile but as image files, transmitted to the ship's computer via modem (Yamaguchi, 1995). In a recent test voyage by a tanker through the Kara Sea in winter, image data from ERS-2, RADARSAT, OKEAN and METEOR were all used to decide the ship's route (Pettersson, 1999, Smirnov, 1999). These projects demonstrated the utility of microwave satellite images as a tool in assessing ice conditions, but also pointed out some of the issues that will have to be addressed in regular NSR operations in future.

* Swath width and resolution

SAR images have an excellent spatial resolution of 100m, providing brilliantly detailed information on ice conditions. The tradeoff, however, is that the swath width is confined to a mere 100km, since the SAR image resolution is dependent on swath beam, incident angle and other factors such as range and azimuth directions. If the vessel is obliged to take a course crossing at right angle away from the axis of the image at a speed of 5 knots, the ship will leave the swath width where SAR images can be received in only half a day. For fixed points, the frequency of receiving SAR images is too low. As the earth rotates, the position of the accessible region changes periodically. Under the normal operation of the ERS satellite, for example, this cycle is three days. Because the swath theoretically covers 300 km at 70°, the satellite can only capture the same area, one third of the NSR, once every three days. The availability of

4. Technological Aspects of NSR Navigation

the SAR images has a spatial limitation. In contrast, the swath width of SSM/I of passive type is wide, enabling each sea region of the NSR to be captured in a single image. The difference in swath width between these two systems can be seen in the images of ice conditions used by the Kandalaksha (Figures 5.8 and 5.9). The disadvantage of SSM/I, of course, is that its spatial resolution is as low as 20 km, revealing only basic surface features such as the edges of ice and ice concentration but no indication of finer details such as presence of ice leads or variations in type of ice. The side-looking radar installed in OKEAN provides a spatial resolution that is intermediate between these two extremes. OKEAN's sensors deliver images with a swath width of 460km, enabling the satellite to cover the entire NSR in the course of 11 orbits. In addition, the image's spatial resolution of 2km is capable of picking up leads in multi-year ice as wide as 500m, and multi-year ice floes as small as 250m (Bushuev, 1998). Finally, RADARSAT, Canada's first earth-resources remote-sensing satellite, offers a region of accessibility of up to 500km. This satellite is expected to provide images much wider than those made available by the other SAR systems.

* The relation between strength of backscattering and ice conditions

Active sensors, particularly SAR, offer not only high spatial resolution but also the possibility of specifying types of ice, such as first-year or multi-year ice. The images captured by active sensors are presented as variations in brightness, converted from the strength of backscattering (reflection) of microwaves radiated from a satellite. The strength of backscattering is a function of the roughness of the ice surface, snow accumulation on the ice cover, salinity of ice and (in the case of open sea) the state of the sea. In using microwave satellite images to discriminate sea ice from open sea and detect various types of ice, it is vital that the relationship between ice conditions and backscattering should be known functions. For this reason, research was conducted to compare satellite images with the results of observations on the surface; those findings appear in Figure 4.2-12 (WP-38). The Y-axis of the diagram shows intensity of backward scattering. As the diagram shows, however, the relationship between backscattering and type of ice is not a simple one-to-one mapping. A certain range of strength of backscattering roughly corresponds to each type of ice, and a given strength of backscattering may correspond to several ice conditions. In producing maps of ice conditions from satellite data, therefore, reference data such as temperature and wind-speed must be taken carefully into account, and the experience and expertise of the mapmakers is crucial.

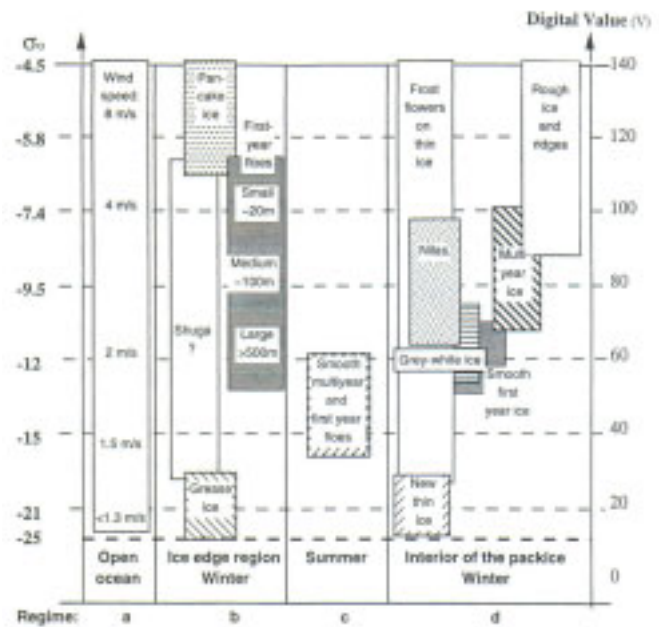

Figure 4.2-12 Relation between the backscattering of the SAR system on the ERS-1 satellite and ice conditions (WP-38)

* Acquisition, processing and transmission of data

Sea ice conditions change constantly with the winds and tides. This means that, when using remote-sensing data on ice conditions to determine actual ship routes, the real-time ice data should

instantaneously be delivered to the ship operators. In the experimental voyages conducted in the NSR, this point of view is incorporated into assessments of satellite data for route determinations. In a recent trial in the Kara Sea, image data from ERS-2 and RADARSAT were received by a land-based station in Tromsø, processed, and transmitted via INMARSAT to the escorting icebreaker. The time taken from image capture by the satellite to delivery to the icebreaker was three to four hours (Pettersson, 1999); Since the time elapsed must be no longer than three to five hours to be useful in using remote-sensing data to determine ship routes (Smirnov, 1999), this result is more or less acceptable. It must be remembered, however, that these results were obtained on a trial basis; normally the acquisition of satellite images is requested several days in advance. This was not a problem during testing, but this requirement will impede availability of data, since data can only be acquired at certain specified times. Moreover, because the sea trial was conducted in the Kara Sea, no problems were expected or encountered in transmitting the satellite image files to the icebreaker via INMARSAT. In the Laptev Sea and adjacent waters, however, such transmission may encounter significant obstacles, which must be solved before these methods come into extensive use.

Although the potential for microwave use in remote-sensing technology is exciting, it is clear that much room for improvement remains in applying the technology to reliable monitoring of sea ice for the NSR navigation. The present situations will clearly demand the increase in polar-orbiting satellites equipped with microwave sensors such as SAR, etc. and other effective solutions.

4.3 NSR Rules and Procedures

In this section we examine the procedures and preparations that foreign shipowners are expected to follow when navigating the NSR. When a ship passes through the territorial waters of a foreign country, the ship has the right of innocent passage. Generally, under international rules, no prior request or inspection of the ship is required. Under international laws to which Russia is bound, the right of innocent passage still exists for areas considered as part of the territorial sea or high seas. In the NSR, however, Russia curtails this right.

The United Nations Convention on the Law of the Sea (UNCLOS) endows coastal states with jurisdiction for the purpose of protecting and preserving the marine environment from pollution in the exclusive economic zone; coastal states have the right to adopt and enforce non-discriminatory laws and regulations for the prevention, reduction and control of marine pollution from vessels in ice-covered areas within the limits of the exclusive zone. Because the NSR is an environmentally sensitive area, citing the need to protect the environment according to UNCLOS, in 1982 the Russian government required all foreign vessels traversing the NSR to obtain advance permission. It also established requirements for ship structures and the experience of the crews in ice navigation; route controls; compulsory escort of ships by icebreakers; and criminal penalties for violating the regulations. In 1990 the USSR's Ministry of Merchant Marine approved the "Regulations for Navigation on the Seaway of the Northern Sea Route." These have been incorporated into the "Guide to Navigating through the Northern Sea Route," an English version of which was published in 1996 by the Ministry of Defense for the NSR Administration. This English-language document provided the basic guidelines applied to all foreign ships plying the NSR, including detailed information on matters such as navigational aids and indications of entry to straits. Also included in this guide was useful information on regulations related to the NSR and technical items for navigating polar seas. The Regulations are non-discriminatory to all ships of any nationality, being designed to ensure safe navigation as well as protection of Arctic marine environment from pollution by ships. Although in setting its own rules the Soviet government followed the example of Canada, which established the Canadian Arctic Shipping Pollution Prevention Regulations (CASPPR) with a

4. Technological Aspects of NSR Navigation

view to protecting the Canadian Arctic environment, the above guide does not always follow international law, and in fact its international validity remains doubtful in some passages. In this section, we focus on information from extracts from "Guide to Navigating through the Northern Sea route" that deals with basic matters such as procedures required for the NSR operations, technological requirements, but we will also touch on the problems of the regulations of the Russian government with respect to international law.

4.3.1 Administration

During the Soviet era, the development of the NSR was framed in terms of a centrally planned economic system and national security. In 1991, when market principles were introduced to the Soviet system for the first time, the administrative landscape in the NSR changed dramatically. Today three levels of government—federal, regional and state-owned enterprise—all play a role in the administration of the NSR. It must be borne in mind that this is simply Russia's unique form of administration. At the federal government level alone, several agencies are involved, including the Administration of the Northern Sea Route, the Marine Administration of Ports and the Arctic and Antarctic Research Institute (AARI). State-owned enterprises such as shipping companies are managed by a State Representative. The government is responsible for providing support for a wide range of duties, such as maintaining safety through information on ice and weather conditions, maintenance of nuclear-powered icebreakers and financial support for maintenance of river shipping routes linked to the NSR. Specifically, the Administration of the Northern Sea Route is responsible for issuing regulations related to the NSR, proposing safety policy, policy regarding the shipment of goods for private companies, instructions to and approval of icebreaker operations, the construction and maintenance of icebreakers, and permission to foreign ships to use the NSR. The Marine Administration of Ports is responsible for the management of state-owned infrastructure such as bridges, tugboats, icebreakers, piloting services and radio communications. AARI gathers data on ice conditions and publishes ice maps.

Each regional government is responsible for the implementation and upkeep of its own basic infrastructure. Although the federal government provides some financial support, responsibility for the infrastructure used in river traffic near the NSR coast falls on the regional authorities. Much of this infrastructure spending is conducted in the form of financing to private-sector companies operating shipping or port-terminal management businesses. Regional governments such as the Sakha Republic, the Yamal-Nenets Autonomous Okrug and the Krasnoyarsk Krai are negotiating with the federal government to have transit levies in the NSR returned to them as a payment for the upkeep of NSR infrastructure. Since 1991, the role of these regional governments in the maintenance of the NSR has increased dramatically. Private-sector shipping companies have established independent businesses and are conducting commercial shipping on the NSR. Presently five such companies are involved in the NSR, of which two are major players: The Murmansk Shipping Company (MSC), operating out of Murmansk, and the Far East Shipping Company (FESCO), based in Vladivostok. The shares of these companies are partly government-owned, and as described above a State Representative is assigned from the federal government to ensure that the wishes of the Ministry of Merchant Marine are followed. Although icebreakers are the property of the federal government, in practice their operation is entrusted to the private shipping companies. MSC, which handles the lion's share of NSR icebreaker operations, began operating nuclear-powered icebreakers under an agreement with the federal government in 1993. Although the federal government is responsible for funding the maintenance of these craft, it is behind in its payments. Of a 200 million-ruble payment due in 1998, it is reported that the federal government disbursed only 43 million rubles, leaving MSC to replace a US\$40 million shortfall. The control of ship routes on the NSR is the responsibility of the MOH. This organization indicates which routes are to be followed, dispatches escorting icebreakers, and

transmits maps of ice conditions. Two MOHs are established for the NSR, one for the area east of 125° E, stationed at Pevek, and the other for the area west of that meridian, located at Dikson. The eastern MOH is responsible for dealing with MSC, and the western MOH for dealing with FESCO, on behalf of the Administration of the Northern Sea Route. A key feature of NSR support and administration since 1991 is the increasing prominence of regional governments in the management of the NSR, as they gain in power and authority at the expense of the federal government amid government organizational reform and continuing economic turmoil. In the months and years to come, it is unclear how financial and administrative responsibilities will be divided among the eastern and western MOH and the Administration of the Northern Sea Route.

4.3.2 Procedure for requesting permission to navigate the NSR

Placement and handling of navigation requests

At least four months prior to an intended voyage on the NSR shipowners must submit a notification and request for guiding to the MOH. Once these documents have been considered, the submitter will be informed of the possibility of navigation and leading and other circumstances to be taken into account. Shipowners and masters cannot simply decide whether to cross the NSR of their own accord. In emergency cases, a request may be submitted only one month in advance, although additional tariffs apply. The following should be included in the request:

- * Name of vessel, flag, owner and full address of owner
- * Gross and net registered tonnage
- * Total displacement
- * Vessel's principal dimensions, engine output, draft, speed and year of construction
- * Ice-strengthening category (ice class), classification society, date of last attesting
- * List of deviations from the requirements to the design, equipment and supply of vessels navigating the NSR
- * Approximate date of the voyage
- * Certification of liability insurance for any damage inflicted by possible pollution of the NSR
- * Purpose of the voyage (cargo transport, tourism, scientific research)

Ship inspection

Within 10 days after acceptance of the request, the Administration of the Northern Sea Route notifies the submitter of its decision concerning the request. If necessary, the Administration orders an inspection of the vessel by the Administration Representatives, in order to grant permission to be guided through the NSR. The inspection, if required, is done at the expense of the owner and can be carried out at the port of Murmansk, Nakhodka or Provideniya, or at another port convenient to the owner. Control inspection of any vessel may be performed while she navigates the NSR. If a ship does not completely satisfy the requirements, she may be allowed to traverse the NSR with icebreaker or other special support provided at additional expense. Guiding of floating docks, drilling platforms, floating piers and their floating structures is permitted through the seaways of the NSR. Guiding of such items is carried out with additional Administration support, provided at additional expense.

4.3.3 Technical requirements for ships

Technical requirements for ships passing through the NSR are provided in "Requirements for the Design, Equipment and Supply of Vessels Navigating the Northern Sea Route," a section included in the "Guide to

4. Technological Aspects of NSR Navigation

Navigating through the NSR" mentioned above. The major requirements listed in this volume are summarized below.

General provisions

- * Ships navigating the NSR must satisfy the applicable Rules of the Russian Federation Registry for vessels containing the following literal designations of ice resistance categories as part of the symbol of their class: L1, UL, or ULA, or the literal designations of the equivalent ice categories used by other classifying organizations, and must also satisfy the requirements of applicable international conventions and the Code of the International Maritime Organization. An approximate comparison is presented by Table 4.1-1 of the literal designations of ice classes between those employed by the Russian and other classification societies.
- * A vessel belonging ice resistance category L1, or equivalent ice class used by other classification societies, may be permitted to travel, under the control of icebreakers, along sections of the Western area of the NSR up to 125 ° E, and along individual sections of the Eastern area of the NSR during the summer navigation period, if navigation conditions are favorable.
- * Icebreakers are permitted to navigate the NSR under ice conditions that correspond to the designation of their respective ice class. On a case-by-case basis, the Administration (Headquarters) may permit the operation of an icebreaker under more severe ice conditions than these envisaged by its ice class. Such permission would be granted following a review of the appropriate documentation, provided by the owner of the icebreaker, confirming that the state of the hull, machinery, and systems of the icebreaker satisfy navigational safety requirements in the NSR area and preclude the possibility of sea pollution.
- * Class-L2 vessels may be permitted as an exception, upon special decision of the Administration (Headquarters), in the summer navigation period in the Western area of the NSR under favorable navigation conditions. Operation in ice of class-L2 vessels in the Eastern area of the NSR is not permitted.

Structure

- * All vessels must have a double-bottom floor throughout the entire width of the vessel and over the entire length between the forepeak and afterpeak bulkheads. Tanks in the double bottom and double sides may not be used for storage of petroleum products or other harmful substances.
- * The cargo tanks of tankers with deadweight greater than 5,000t used to transport petroleum products, as well as the cargo tanks of chemical carriers and gas carriers, must be situated at a distance of not less than 0.76 m from the outer sheathing of the vessel hull. Tanks in the double-bottom floor and the double-sides of tankers may be used as tanks for isolated ballast, or must be kept empty.
- * The hull of the vessels must have a shape appropriate for navigation in ice-covered waters. If hull shapes are different from these recommended by the Russian Rules, operation of such vessels on the NSR must be approved by the Administration. Bulbous bows are not accepted.
- * Russian ships built before 1981 are subject to special inspection by the Administration.
- * To ensure the possibility of close towing of the vessel by an icebreaker, additional supports to the sheathing and framing must be provided in the bow part of the vessel hull. It must also be possible to fasten a tow line to the tip of the bow. If necessary, devices should be provided for removal and stowing of anchors onboard the vessel (Figure 4.1-10).

Engine

- * The time taken to reverse the main propulsion engine (in maneuver mode), or to switch the blades of the controllable-pitch propeller from full ahead to full astern, must not exceed 45 seconds.

- * In reverse (full stern) operation, the main propulsion engines must provide at least 70% of the rate of revolution of the forward running mode.
- * The propellers must have at least four blades and be made of stainless steel or high-strength bronze. Detachable blades are preferable.

Systems and devices

All vessels must be equipped with a closed wastewater system that includes a device for biological cleaning or physicochemical treatment and sterilization of wastewater. A wastewater collection tank must be provided with capacity sufficient for 30 days' navigation.

- * The ballast tanks adjacent to the outer side above the load waterline, including the tanks in the vessel's double side, must be supplied with a heating system to prevent freezing.

Navigational and communications equipment

The following equipment must be installed aboard ships, together with standard means of navigation.

- * A gyrocompass with repeaters at all control stations, fathometer and direction finder
- * Vessels with gross tonnage of more than 1,600t and all passenger ships must be provided with two radar sets that operate independently of each other. It is recommended that one set have a wavelength of 10 cm. Vessels with lesser tonnage must have a single radar set with wavelength of 3 cm.
- * Radio or satellite navigation system that enables position of the ship to be determined to within at least 100 m with 95% probability
A radio log or an acoustic log for measuring ship speed, with a system of transmitters and receivers protected from possible collision with ice
- * In addition to ordinary means of radio communications, all vessels must be provided with the following equipment:
 - Onboard ground station for satellite communications
 - Navigational warnings receiver (NAVTEX)
 - Satellite emergency radio buoy (satellite EPIRB)
 - Instruments for sound recording and reception of facsimiles, including receipt of maps of hydrometeorological information
 - VHF station for communications with airplanes, helicopters and vessels traveling in a convoy and operating at a frequency of 122.5MHz

Provisions and emergency facilities

- * At the start of a voyage along the NSR, each ship must be provided with a double store of fuel and lubricants. In case of transit navigation along the NSR, stores of fuel and lubricants must be sufficient for 30 days. Stores of provisions and fresh water (taking into account replenishment from a distilling plant) and all other types of ship provisions must be sufficient for at least 60 days.
- * Spare parts, instruments and firefighting equipment must be available onboard the ship and conform to the rules of Russia's or other classification societies. In addition, the set of spare parts must include a screw propeller or, in the case of propellers with detachable blades, two spare blades for each propeller.
- * In addition to the spare parts required by Russia's or other classification societies, an assortment of other items are required, such as pulleys and notch blocks for changing blades and propellers, portable gas-welding equipment for welding and cutting, searchlights, portable electric submersible pump with a set of hoses, sets of warm clothing and hydrothermal suits.

4. Technological Aspects of NSR Navigation

4.3.4 Navigational requirements

Crew

- * The size of the crew for navigation in ice must be large enough to guarantee a three-shift watch.
- * The ship master (captain) or a person substituting for him on a bridge watch must possess the minimum level of knowledge of navigation in ice: experience of steering vessels under ice conditions along the NSR for not less than 15 days. In the absence of such experience, the presence of an ice pilot aboard the vessel is compulsory.
- * The ship master or a person substituting for him on a bridge watch must know the signals that are employed by icebreakers during leading through ice and presented in the Guide to Navigation.
- * Radiomen must know the rules of radio communications in the Arctic.
- * The crew of the vessel must be forewarned concerning prohibitions against discharging pollutant substances and rubbish on the NSR as well as responsibility for any pollution of the sea and ice cover.

Other

- * The ship must be furnished with the requisite maps published by the Russian government.
- * As insurance against pollution damage, the Regulations state that “vessels will not be permitted to navigate the NSR if they do not have aboard a certificate of due financial security with respect to the civil liability of the owner for damage inflicted by polluting marine environment and the northern coast of Russia.” In practice this means that all ships must be sufficiently insured.

4.3.5 Control of Ship Routes and Selection of Routes

The operations of the vessel in the NSR are stipulated in the "Regulations for Icebreaker and Pilot Guiding of Vessels through the Northern Sea Route." The gist of the main rules is provided below. Ships traveling the NSR are obliged to follow the instructions of the competent MOH.

- * The ship is obliged to follow the route indicated by the MOH.
- * Ships traveling the NSR west of 125 ° E are guided and controlled by the West MOH, while ships traveling the NSR east of 125 ° E are guided and controlled by the East MOH.
- * Guide services are divided into several levels according to the judgment of the MOH, taking the ice conditions into account: Guiding from the shore along recommended routes up to a certain geographic point; guiding by airplane or helicopter; conventional pilotage; icebreaker guiding; and icebreaker guiding combined with conventional pilotage of vessels. Note that according to the Regulations, guidance is not always provided by an icebreaker. In the four straits of Vilkitskiy Strait, Shokalskiy Strait, Dmitry Laptev Strait and Sannikov Strait, guiding by icebreaker is required if ice conditions are deemed to endanger the safety of the ship. In the straits of Proliv Vil'kitskogo, Proliv Shokal'skogo, Proliv Dmitriya Lapteva and Proliv Sannikova, icebreaker guiding of vessels with an ice pilot on board each guided vessel is mandatory due to unfavorable navigational conditions.
- * MSC provides icebreakers for the Arctic West Region, up to the meridian 125 ° E, and FESCO provides icebreakers for the Arctic East Region, east of the meridian 125 ° E.
- * Ship owners or masters must notify the MOH of the date and time of their entry into the NSR in advance.
- * Mode of operations, independent or in convoy, is determined according to the judgment of the MOH.
- * When a convoy is formed, the convoy is under the command of the guiding icebreaker.
- * Any attempt by a vessel's command to avoid the type of guidance assigned by the MOH is considered a violation of section 7 of the Regulation, and in accordance with section 10 of the Rules entails the removal of the vessel from the Route. All expenses associated with the removal of the vessel are borne by

the vessel's shipowners.

- * The MOH indicates the most favorable route to the meeting point with an icebreaker, taking into account the current ice conditions.
- * The ship must notify the MOH of its position twice a day.
- * The instructions of the MOH follow Russia's sea maps and other marine publications. The traveling ship must therefore be in possession of said Russian maps and all revisions thereto.
- * All information on changes in navigational conditions in the NSR area, as well as changes or additions to the present Regulations, is promulgated by the MOH via radio stations in Dikson, Amderma, Tiksi, Pevek and Shmidta.
- * Vessel masters who neglected the warning information (PRIP) on coastal areas issued by the Ministry of Defense cannot later allege unpredictable circumstances if they find themselves in difficult situations.
- * Even when navigating without icebreaker or ice pilot, in clear water or open ice that does not hinder navigation, vessel masters must not deviate considerably from the recommended route. If the ship's command commits an unauthorized deviation from the recommended route, and as a result the vessel encounters a difficult situation because of heavy ice, shallow water, or for other reasons, the vessel master should not expect the quick and timely assistance of an icebreaker, airplane, helicopter and the MOH.

4.3.6 Evaluation in Terms of International Law

The Russian government's regulations on shipping in the NSR have been deserving of criticism in terms of international laws. Although Russia's territorial waters conform to the interpretation of the United Nations Convention on the Law of the Sea (UNCLOS) in 1982 as a distance from shore of 12NM, key problems arise in the legal interpretation of the right of passage through the various straits of the NSR. Due to the inherent vagueness of UNCLOS Article 234, it would be difficult to argue that the Russian practice is excessive. The United States claims that the ice-covered straits of the NSR are international and subject to the right of transit passage, while Russia claims them as internal waters under several theories of international law. In this section we introduce some of these contentious legal issues.

UNCLOS, Article 234

Article 234 of UNCLOS states that "Coastal States have the right to adopt and enforce non-discriminatory laws and regulations for the prevention, reduction and control of marine pollution from vessels in ice-covered areas within the limits of the exclusive economic zone, where particularly severe climate conditions and the pressure of ice covering such areas for most of the year create obstructions or exceptional hazards to navigation, and pollution of the marine environment could cause major harm to or irreversible disturbance of the ecological balance. Such laws and regulations shall have due regard to navigation and the protection and preservation of the marine environment based on the best available scientific evidence." Countries possessing coastlines on the Arctic Ocean are permitted to pass their own legislation for the purpose of protecting the natural environment of the Arctic Ocean. The governments of Russia and Canada both establish their own regulations on this basis.

Regulations on navigation of the NSR

Based on Article 234 of UNCLOS above, Russia enacted the "Regulation for Navigation on the Seaway of the Northern Sea Route" in 1990; this law became effective in September 1991. This Regulation, which is the basis of Russia's legal framework governing the NSR, governs navigation not only in Russia's exclusive maritime economic zone but also in the high seas beyond it. Russia's regulations on navigation of the NSR are summarized in Section 4.3.5 above. Some unusual aspects of these regulations are presented below.

4. Technological Aspects of NSR Navigation

- 1) A vessel to be used in NSR navigation shall satisfy certain special technical and operational requirements. The ship's master or a person that performs the master's duties shall be experienced in operating the vessel in ice. In cases where those persons have no such experience, the Administration may assign a State Pilot to the vessel to assist in leading the vessel.
- 2) To be admitted for navigation of the NSR, the vessel must carry on board a certificate of financial security with respect to the civil liability of the owner for any damage inflicted by polluting marine environment.
- 3) Owners or masters of vessels intending to navigate the NSR must provide advance notice of their entry and passage to the Russian authorities in documentary form. The document is examined and the applicant is then notified of the status of approval, based on various conditions of the vessel.
- 4) The MOH, which is the control and service agency of the Russian government, acting on the basis of MSC and FESCO, controls ship traffic in the NSR. The MOH reports to the Administration of the Northern Sea Route.

Key problems in Russia's legal framework

In INSROP, a number of controversies surround the coordination of Russia's regulations on shipping in the NSR with UNCLOS. The main points of contention are listed below; opinion varies widely regarding the range of seas covered and the transit fees levied. Despite these problems, it is impossible to navigate the NSR without abiding by Russia's regulations on shipping in the NSR.

- 1) Transit fees are levied on ships traveling the NSR, based on each ship's type and deadweight tonnage, citing reasons of safety and risk in environmental preservation. It is unclear, however, whether Russian ships are also subject to these fees. If they are not, this constitutes a violation of Article 234, which requires that regulations be applied without discrimination. Neither Canada nor the United States levies such transit fees.
- 2) Transit fees may be levied for services rendered, but the forcible extraction of payment for passage alone is a violation of Article 26 of UNCLOS, which recognizes the right of unhindered passage. Still less can such fees be extended to an exclusive economic zone.
- 3) Article 230 of UNCLOS provides only for financial compensation in the event of damage caused by foreign ships. Except for grievous pollution caused by negligence, appropriate limits are placed within territorial waters. Under current Russian law, however, violations of environmental law in the exclusive economic zone are subject to fines. Moreover, where necessary vessels may be detained, crew members arrested and violators expelled.
- 4) Article 234 recognizes rights within the country's special economic zone. Current Russian law is vague regarding whether that zone is limited to 200NM or not, defining its area of jurisdiction as the "marine area adjacent to the northern coast." This could be interpreted to include the high seas beyond the special economic zone. The United States clearly limits its jurisdiction to its special economic zone, and Canada establishes a range of 100NM from the shore. Russia's expression, which could be taken to include the high seas, is not accepted in international law.

Canadian Arctic Shipping Pollution Prevention Regulations (CASPPR)

In Canada's Northwest Passage, which links Baffin Bay to the Beaufort Sea, the Canadian government has declared that the waters of the Arctic Archipelago constitute internal waters, since the territorial waters extending 12NM from shore overlap throughout the straits between these numerous islands. Canada has also stipulated territorial waters and exclusive economic zones, through which Canada grants permission to navigate provided such ships satisfy Canadian environmental law. Canada's special economic zone is set not at 200NM from shore but at 100NM. Although the United States and other countries object to these provisions, American ships obey Canadian law when navigating these waters. As reference, a schematic view of all legal

demarcations in the Arctic Ocean, including the NSR, is provided below (Figure 4.3-1, WP-75).

4. Technological Aspects of NSR Navigation

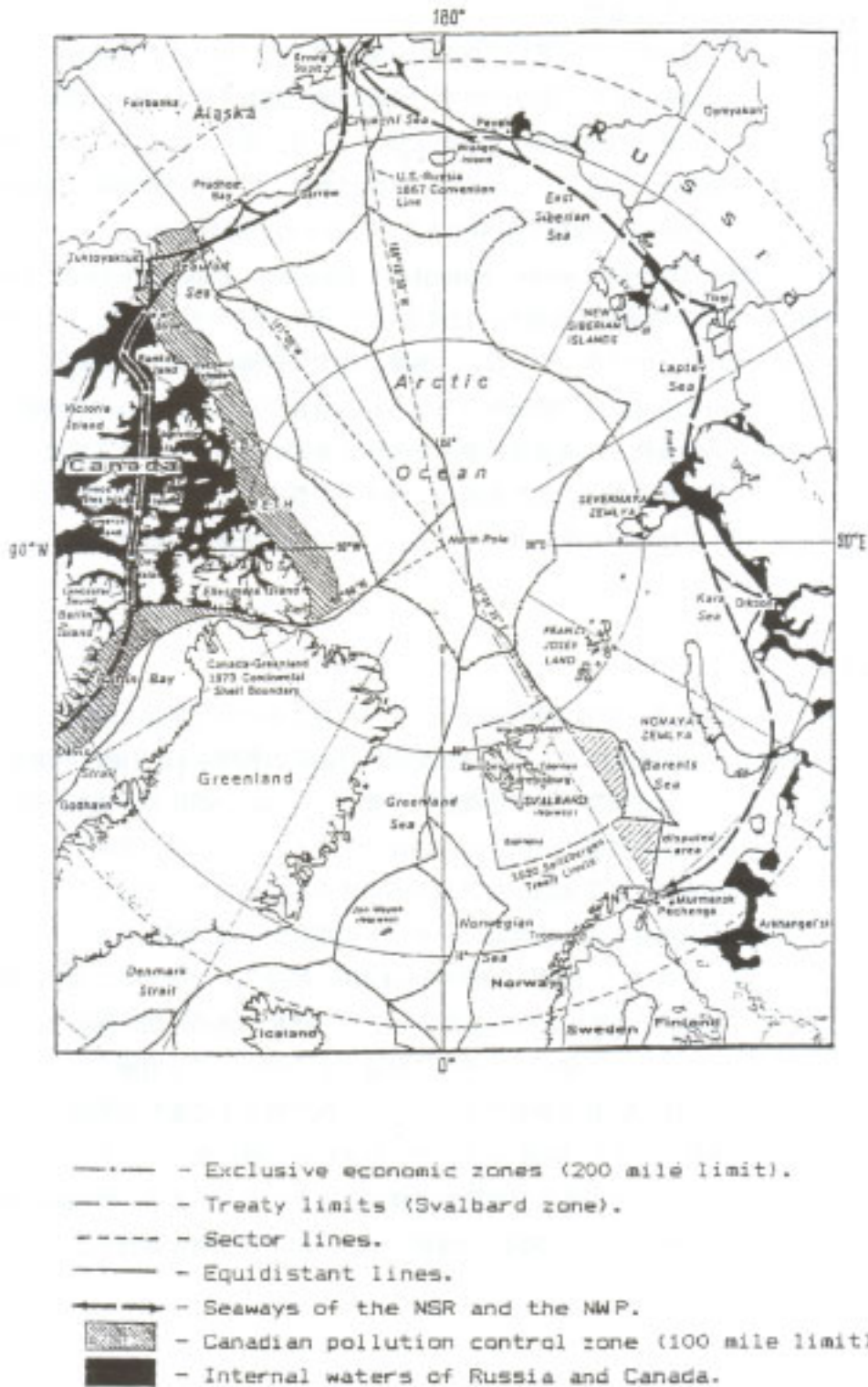

Source: A. Yakovlev, A. Arikainen, O. Kossov and A. Ushakov: 'Political Aspects of International shipping along the Northern Sea Route', INSROP Working Paper No. 75-1997 IV.2.2, p.36.

Figure 4.3-1 Legal demarcations in the NSR and Northwest Passage

Historical rivalry between the United States and the Soviet Union

The United States has been consistently opposed to Russia's legal stance on the NSR and has refused to ratify UNCLOS. In terms of the impact of Arctic issues on relations between the two countries, the NSR is one of the biggest bones of contention. Both sides are adamant in their positions, which are diametrically opposed. Russia has declared the waters of the straits between its shores to be internal waters, whereas the United States asserts its right of passage through what it regards as straits in international waters. Each country defends its position in terms of national security interests. In its defense Russia can marshal a number of arguments. The Vilkitskiy, Shokalskiy, Dmitry Laptev, Sannikov, Eteriken, Yugorskiy Shar, Kara Gate and Red Army Straits are all less than 12NM wide, arguing strongly for their status as territorial waters. Moreover, historically little maritime traffic other than Russia's own has ever passed through the NSR. In cases where straits abut the territorial waters of another country, or provide the only means of maritime entrance to the waters of another country, some straits have been designated international waters, but neither of these conditions applies to the straits in the NSR. The United States' grounds for supporting its assertion of right of passage is weak, and most third parties appear to support the Russian position. As stated above, the United States also opposes CASPPR, Canada's Arctic environmental regulations. This stance is consistent with the American refusal to ratify UNCLOS.

4.3.7 Conclusion

In the foregoing discussion of procedures required for navigation of the NSR and the legal background to those requirements, we have found much that is inconvenient and unsatisfactory to civilians and companies intending to ply these waters. The demand for four months' advance notice of NSR navigation is hard to coordinate with the contracts of tramp operations, which are often chartered for much shorter periods of time. Both recent and current data on ice conditions, which are crucial in proposing routes and estimating travel times, are not made available free of charge. Persons who must have data and forecasts on ice conditions vital for navigation can only obtain them by paying a fee to AARI or other governmental organizations. When the time and effort of concluding contracts and so forth is considered, NSR shipping remains a distant prospect for today's shipping market, which requires fast decision-making. On a cost-benefit basis, NSR shipping is at present hard to justify. As is described in Section 4.4, transit fees, or tariff structures for the NSR are by no means acceptable in comparison to the route via the Suez Canal, and even after the fee is paid there is no guarantee that the NSR will provide speedy and fully safe passage. It is our hope that Russia will begin to provide clear guarantee of the services it provides in exchange for its transit fees. At present, the opening of the NSR is only at the phase of laying the appropriate legal groundwork, since physical preparations are so poor. The advanced state of dilapidation of the NSR infrastructure put into place over many years is now becoming apparent. If this infrastructure crumbles completely, it will have to be rebuilt at great expense. Revamping the navigational and legal system of the NSR to provide acceptable convenience to the international shipping market, partly through the demonstrative effect of test voyages, is an urgent priority.

4.4 Evaluation of Economic Viability

In this section we weigh the business case for the NSR. Drawing on publicly available documents, this section touches on changes to shipping volume from the past to the present, as well as seasonal variations of shipping, types of cargo and issues of profitability in light of Russia's state of economic upheaval. Going forward, this section also looks at a hypothetical scenario for stimulating development of the NSR, in which the transit cargo between the Far East and Europe through the NSR is greatly increased, examining which types of

4. Technological Aspects of NSR Navigation

cargo can be shifted to NSR transit shipment. In order to enable clear and specific proposals for the type of shipping framework needed and to identify needed improvements for Phase II of INSROP, a design study and cost simulation were carried out for future NSR cargo ships larger than the SA-15, taking into account trends in the international shipping market. We present the results of these studies and conclude with an assessment of the viability of a commercial shipping lane through the NSR.

4.4.1 Changes in Shipping Volume

NSR shipping reached its highest volume in history in 1987, at 6.58 million metric tons. Since that time, NSR shipping has been in steady decline (Table 4.4-1). With the exception of a slight upturn in 1995 against the previous year, the slide is unbroken. Volume reached 2.36 million metric tons in 1995, then tumbled to 1.64 million metric tons in 1996—less than a quarter of the volume at the NSR's 1987 peak. The main reason for the boost in volume in the late 1980s was the development of natural resources. In the west, the increase in domestic shipping volume was supported by the exploitation of oil and gas, along with copper, nickel and scarce metals in Norilsk; in the east, scarce and other non-ferrous metals, including gold, were shipped from Chukotka and Yakutia, but their volume was much lower than in the west. Table 4.4-2 shows a breakdown of the imports and exports item in Table 4.4-1. Exports of nickel and other metals from Norilsk began in 1968 and reached 2.5 million metric tons, comprising 40% of total shipments. In 1976 gas fields began to be exploited in the Yamal Peninsula, and by 1988 a cumulative total of 102,000 metric tons had been produced. In connection with this project, pipeline construction equipment was exported from Japan. Timber from Siberia, derived chiefly from the Igarka area, trended in the neighborhood of 700,000-750,000 t in the 1980s. These exports peaked in 1990 at 1.2 million metric tons, then dropped significantly in 1991 and 1992 before rising again in 1993. Although the table does not indicate it, in 1996 a precipitous decline in timber shipping occurred. This is because the trade was suspended when a change in the system of taxation rendered lumber exports from Igarka and Tiksi unprofitable. Imports stayed at an extremely low level until the early 1990s, when gas exports from the Yamal Peninsula stimulated a burst of imports, including 57,000 t of machinery and foodstuffs in 1994. The figures in Tables 4.4-1 and 4.4-2 are derived from Russian statistics; please note that some inconsistency exists among the various items in the tables. In any event, amid the present economic and political instability in Russia it is difficult to forecast the future state of NSR logistics and reach a firm decision on the basis of these figures.

Table 4.4-1 Dynamics and directions of NSR cargo shipment, 1945-1995 (Unit: 1,000 t)

	1945	1960	1970	1980	1987	1990	1991	1992	1993	1994	1995
Deliveries to the Arctic from other regions of the USSR, total	71.4	349.1	1563.0	2279.9	2943.6	2490.4	2261.6	1806.9	1413.6	795.3	829.3
Of which: From the west	63.9	188.1	932.0	1418.9	1808.1	1355.1	1193.8	974.4	768.9	573.5	576.8
Of which: From the east	7.5	161.0	631.0	861.0	1135.5	1135.3	1067.8	834.5	644.7	221.8	252.5
Deliveries from the Arctic to other regions of the USSR	116.2	113.4	392.7	1292.3	1684.7	1556.0	1450.7	1272.2	728.5	710.3	766.0
Intra-Arctic coastal shipment	85.4	88.0	340.7	398.6	358.6	136.2	170.0	169.7	95.3	18.3	10.8
External commercial shipments	171.1	412.0	683.6	980.6	1590.7	1212.8	745.5	456.1	520.3	636.0	655.5
Of which: Export	51.3	412.0	616.9	888.1	1080.9	1201.0	743.6	450.8	517.3	578.9	606.0
Of which: Import	119.8	0	66.7	92.5	509.8	11.8	1.9	5.3	3.0	57.1	49.5
Transit	0	0	0.1	0	1.0	115.1	176.2	202.3	208.6	140.2	100.2
Total	441.1	962.5	2980.1	4951.4	6578.6	5510.5	4804.0	3909.2	2966.3	2300.1	2361.8

Table 4.4-2 Export and import of cargoes along the NSR (Unit: 1000t)

	1990	1991	1992	1993	1994	1995
Export, total	1201.8	743.6	450.8	517.3	578.9	606.0
Of which:						
Timber from Igarka	711.3	448.2	247.2	296.5	297.6	272.7
Timber from Tiksi	147.6	47.6	67.2	95.9	42.4	19.6
Non-ferrous metals from Dudinka	164.1	90.7	80.3	116.7	222.8	302.4
Nickel matte from Dudinka	29.3	17.1	13.7	6.0	2.6	-
Sulfur from Dudinka	106.6	15.1	-	-	-	-
Coal from Yakutia	25.9	108.7	39.0	-	-	-
Condensate from the Yenisey and Yamal	-	-	-	-	13.5	11.3
Imports, total	11.8	1.9	5.3	3.0	57.1	49.5
Of which:						
Coal to Novaya Zemlya from Poland	8.9	-	-	-	-	-
Steel pipes to the Ob Bay	-	-	-	3.0	1.3	-
Steel pipes to Dudinka	2.9	-	0.1	-	9.1	3.7
Steel pipes to Pevek	-	-	-	-	30.5	20.4
Steel pipes to Mys Shmidta	-	-	-	-	14.4	19.5

4.4.2 Present State of Shipping

Seasonal effects on shipping volumes

Annual navigation along the NSR involves two main seasons; the traditional (summer) navigational season and the extended season. The latter consists of autumn, winter and spring, after the traditional season is over. In 1995, 60.6% of shipping was conducted during the traditional season and 39.4% in the extended season (autumn, 13.6%; winter, 12.6%; spring, 13.2%). The shipping is chiefly governed by the ice conditions in the Kara Sea. Shipping in the regions east of the Vilkitskiy Strait generally begins in May and ends in November. Shipping from Murmansk to Dikson up on the Yenisey River can be accomplished year-round with the support of an icebreaker, and has long been conducted by ULA- and UL-class ice-breaking ships with icebreaker assistance.

Shipping amid the economic crisis

Although Russia's economic crisis is said to have begun in 1990, in the Far North it began earlier, as public investment in port facilities began to dry up and further exploitation of oil and mineral resources failed to materialize. The tumult from the transition to a market economy caused imports to stagnate. Like industries throughout the former USSR, icebreaker and port management in the NSR fell on hard times. When inflation ravaged Russia in 1992, it dealt a devastating blow to the people, particularly ethnic Russians, living in the NSR region, who had hitherto enjoyed comparatively high salaries. Production volumes in the gas, oil, non-ferrous-metal, chemical-feedstock and timber industries contracted sharply. Prospecting for mineral resources fell to a third of their previous level, and government investment all but stopped. These grim conditions precipitated an exodus of the ethnic Russian population from the region. 2.1% of the population of Murmansk left between 1991 and 1993; in Chukchi, the figure was 10.7%. Clearly, the reasons for the decline in activity in the NSR during this time were the collapse of capital investment in the north and the attendant decline in the region's population. It is not the decline in NSR shipping that caused the economic crisis in the Arctic, but rather the reverse: the decline in shipping was a natural consequence of the chaos occasioned by the economic crisis. Significantly, however, the NSR vessels have maintained shipping capability for chartered cargoes with an acceptable level of reliability. In contrast, rail cargo links were frustrated by poor reliability. Many rivers flow down to the NSR coast, passing through regions of permafrost to fuse regional river and marine shipping with NSR shipping. It is clearly hoped that the NSR will therefore serve as a shipping route for

4. Technological Aspects of NSR Navigation

the wealth of natural resources with which northern Russia is blessed. When the resources of each of northern Russia's regions begin to be developed in a planned and orderly fashion, the value of the NSR will become apparent.

NSR shipping companies and their earnings structure

The management of the NSR is handled by the Northern Sea Route Administration, together with other structures within the Service of Marine Transport of the Ministry of Transport of the Russian Federation. Transportation is regulated by the following joint stock companies, although the understanding of what constitutes "public" and "private" enterprise in Russia differs greatly from the definitions of these concepts in Japan.

- | | |
|--|----------------------------|
| * Murmank Shipping Company (MSC) | (Head office: Murmansk) |
| * The Northern Shipping Company | (Head office: Arkhangelsk) |
| * The Arctic Shipping Company | (Head office: Tiksi) |
| * The Far Eastern Shipping Company (FESCO) | (Head office: Vladivostok) |
| * The Primorsk Shipping Company | (Head office: Nakhodka) |

Icebreakers are owned by the government, but their operation is entrusted to the above-mentioned shipping companies or to port management authorities. Therefore, the government should be responsible for financing the maintenance of the nuclear-powered icebreakers used by MSC, but in fact those payments are currently suspended. The shipping companies suffer from a significant and chronic shortfall between the shipping fees they receive, which are mandated by the federal government, and the costs they must pay out. Due to the fall of the ruble, these enterprises are drawn away from NSR shipping by the high profitability of hard-currency overseas shipping compared with the low return on NSR shipping. Their fixed costs in terms of icebreaker maintenance are also rising rapidly just as NSR shipping volumes are declining. According to (admittedly rather old) data from 1993, NSR revenues cover only 67% of expenses, as opposed to 240% in the case of overseas shipments. In other words, the more NSR shipping these companies do the greater their losses become, whereas overseas operations are irresistibly lucrative. Shipments abroad, comprising 26% of the total volume of shipments, brought in 63% of total revenues and 75% of total profit of the SMT transport fleet. This overseas profit is used to maintain icebreakers, conduct domestic shipping, pay crews' salaries and maintain fleets. Another revenue stream comes in the form of Arctic tourism, in which overseas travel companies charter icebreakers for sightseeing excursions.

4.4.3 Potential for Transit Traffic on the NSR

Appropriate commodities for the NSR transportation

In the shipping industry, reliability is more important than cost. It is insufficient for the NSR simply to be shorter and cheaper than the alternatives. Container shipping is ill suited to the NSR because of lack of regularity and punctuality of navigation, and luxury goods that are apt to deteriorate in extreme thermal conditions are similarly inappropriate. According to the analysis of many shipping firms, in the early days at least the NSR will be best used to ship low-value bulk cargoes.

Transit Cargo that can be Shifted to the NSR

NSR transit cargoes between Europe and Asia and between Europe and the west coast of North America without calling at any of the ports along the NSR coast—totaled no more than 100,000 t in 1995. If the NSR could fulfill its potential as a reliable, low-cost shipping route, a considerable volume of traffic could be diverted from the Suez route. To analyze trends in transit cargo, the characteristics of the NSR shipping system and the potential volume and types of cargo must be carefully considered. Although cost-competitiveness is

important in the selection of means of conveyance, reliability of delivery is a crucial criterion as well. As stated above, the NSR must be not only short and cheap but also reliable enough to satisfy shippers.

Based on the present potential cargo movement, it may be possible to find a shipment format that is appropriate for NSR transit shipment. Obviously increasing the volume of shipping through the NSR means diverting traffic bound for the EU, the Far East and the West Coast of North America that is currently routed through the Suez or Panama Canal. The volume of petroleum products, minerals, fertilizer, grains, metal products, chemical products and cement that is currently shipped from the EU to Japan, South Korea, China, Hong Kong and Taiwan is approximately 16 million metric tons. Potential also exists in the NSR for shipment of finished commodities such as automobiles, consumer electronics, copy machine and electronic components. These are high-value products which require special ships or container ships, and must be delivered at regular intervals and within a specific time-frame. Equally importantly, these goods are susceptible to deterioration from the harsh thermal conditions of the NSR. The special measures required to protect the cargo are certain to raise the freight rate, and may render NSR shipping uneconomical.

In 1996, 5 million metric tons of cargoes were shipped from Russia and the three Baltic countries to Asia-Pacific. About half of this volume was bound for China. In a breakdown by product type, the most common cargo items were metal products and fertilizer (Figure 4.4-1). These products are ideal for the NSR because they have relatively little sensitivity to delivery time and are resistant to extremes in temperature. Isakov et al. reported that, given improvements to the tariff structures and port tax imposed in the NSR, 1.7-1.9 million metric tons of the 5 million metric tons of this trade could be diverted to the NSR (WP-139). In sum, the most likely scenario for stimulating transit commodities through the NSR is to start with bulk cargoes that are relatively low in regularity, flexible in delivery schedules and resistant to extremes of cold. One special application might be summer shipment from Europe to Japan of marine products for which freshness commands a premium.

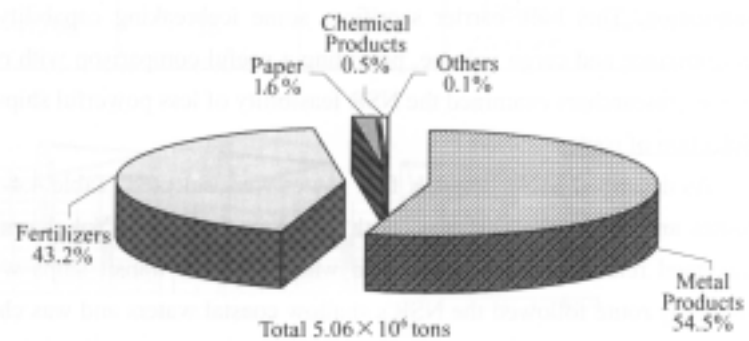

Figure 4.4-1 Cargoes exported from Russia and the Baltic countries to Asia-Pacific

4.4.4 Cost simulation

As mentioned in the discussion on variations in NSR cargo, Russia's freighters today carry little more than a modest flow of transit cargo to China and other Asian destinations. When asked how profitable NSR shipping could become if certain types of ship were introduced, many people involved in shipping market are frankly skeptical that the NSR could be cost-competitive. These doubts demand a clear response. Therefore, in Phase II of INSROP an operation simulation project was conducted to calculate shipping costs through four representative NSR routes, using three newly designed vessels larger than the SA-15 (WP-164). Key elements in the simulation were algorithms that expressed the relation between the ship's speed and factors that can slow it down, such as ice thickness and concentration and presence of pressure ridges, as well as measures to ensure the accurate recording of ice data. In the previous cost simulations of NSR navigation, the ship transit speeds were simply determined based on the empirical data or a simple look-up table defining the relation between ice

4. Technological Aspects of NSR Navigation

conditions and ship speeds, or even monthly average speeds.(Wergeland, 1992; Schwarz, 1995; Mulherin, 1996). Those crude simulations were inadequate to determine the feasibility of the NSR. In this simulation, new mathematical models were developed to predict ship speed under various ice conditions. The AARI's historical ice data for the past 40 years were analyzed along each NSR route, for an accurate and precise evaluation of the relation between ice conditions and ship speed. Two approaches were available for description of ice conditions. The first approach was based on probabilistic descriptions of ice thickness, ice concentration and so forth in each region along the routes, applying the Monte Carlo technique or similar methods. The alternative approach was to evaluate ship speeds through long-term virtual voyages, extrapolating ice conditions continuously in time domain for the period of the historical data. In this simulation, the latter method was selected, as the Monte Carlo method cannot give realistic simulations for the negative correlation between the ice conditions of the east and west NSR; namely when the ice conditions in the East Siberian Sea are heavy, those in the western NSR are light, and vice versa (see Section 3.3.3). This simulation made full use of the reliable propulsion performance data for transiting vessels, obtained through model tests in ice model basins, while excluding uncertain predicted data to improve accuracy in the simulation as much as possible. The present simulation appears to be the most comprehensive yet available. Research agencies from Russia, Finland and Japan participated in this simulation. While Russia afforded the data and information of routes, ice and meteorological statistics vital for the simulation, Finland was in charge of conceptual design of the vessels and development of ship speed code in ice. Japan integrated all of the data from the other partners and produced the cost simulation program to yield the final cost calculation. 50,000 DWT bulk carrier developed by JANSROP was also evaluated through the simulation. This bulk carrier sacrifices some icebreaking capability in exchange for enhanced open water performance and cargo volume, providing a useful comparison with other types of ship. Using the bulk carrier model, researchers examined the NSR feasibility of less powerful ships with larger cargo volumes.

Selection of routes

As described in Section 4.1, four routes were selected (Table 4.4-3, Figure 4.2-8), consisting of two transit routes and two regional routes. Both transit routes linked Yokohama directly to Hamburg. A northerly route traversed relatively deep waters and was suited for transit ships with drafts up to 12.5m, while a second, southerly route followed the NSR's shallow coastal waters and was chosen for ships with drafts less than 9.0m. Of the regional routes, a regional west route connected Dikson in the western NSR with Hamburg, and a regional east route linked Tiksi with Yokohama. In actual operations, routes will be selected to avoid the most grueling ice conditions, according to the instructions of the MOH as described in Section 4.3, but for simulation purposes these fixed routes were assumed. The routes were plotted for every 20 NM on the sea charts published by the Russian Government, taking into account ice conditions and water depths. The regional east and west routes both followed the southern route as soon as they departed their respective ports of Dikson and Tiksi.

Table 4.4-3 Distances of four routes used in the simulation (NM)

Route name	Port to port	Distance within NSR, NM(%)	Distance outside NSR, NM (%)	Total distance, NM (%)
Northerly route	Hamburg to Yokohama	2,446 (34)	4,750 (66)	7,196 (100)
Southerly route	Hamburg to Yokohama	2,680 (37)	4,650 (63)	7,330 (100)
Regional east route	Tiksi to Yokohama	1,326 (33)	2,694 (67)	4,020 (100)
Regional west route	Dikson to Hamburg	468 (20)	1,929 (80)	2,397 (100)

Selection of service ships

In the analysis of NSR commercial ships in Section 4.2, we noted that the most modern ice-breaking freighter currently operating in the NSR is the SA-15 class of vessels. Unfortunately its capacity is only 15,000

DWT. To reduce operational cost and raise profitability, the largest possible vessel should be introduced. In this simulation, therefore, INSROP conducted conceptual designs of large vessels with drafts of 9m and 12.5m and proposed new hull forms (Table 4.4-4, Figure 4.4-2). These ships would be escorted by an icebreaker under adverse ice conditions, so their beam must be narrower than the icebreaker in order to be able to pass through the open water channel created by the icebreaker. Currently the largest icebreaker in service along the NSR is the Arktika class, with a beam of 28m. Because ships with ordinary hull forms break ice slightly wider than their breadths, an escorted ship can enjoy a channel slightly wider than the breadth of an escorting icebreaker; in the Arktika’s case, about 30m. Accordingly INSROP decided that the escorted ship should be no more than 30m wide. To obtain the right displacement under the limitations on the draft and beam, the ships must feature a high length-to-beam ratio. Some key particulars of the three ship types used in the simulations are given below. For more detailed information, please see the data in Section 5-2.

Table 4.4-4 Key particulars of three ships used in the simulation

Feature Ship type	Length (Lpp) × beam (B) × draft (m)	Cargo tonnage (metric tons)	Normal shaft horsepower (MW)	Speed in open water (knots)	Icebreaking capability(m)	Route
25,000 DWT Icebreaking bulk /container ship	184.1 x 25.1 x 9.0	21,500	24	14.5	1.85m at 1.0 m/sec	Southerly route Regional routes
40,000 DWT Icebreaking bulk /container ship	186.1 x 27.5 x 12.5	36,000	28	14.5	1.85m at 1.0 m/sec	Northerly route
50,000 DWT Icebreaking bulk carrier	240.0 x 30.0 x 12.5	47,000	18	17.0	1.2m at 1.5 m/sec	Northerly route

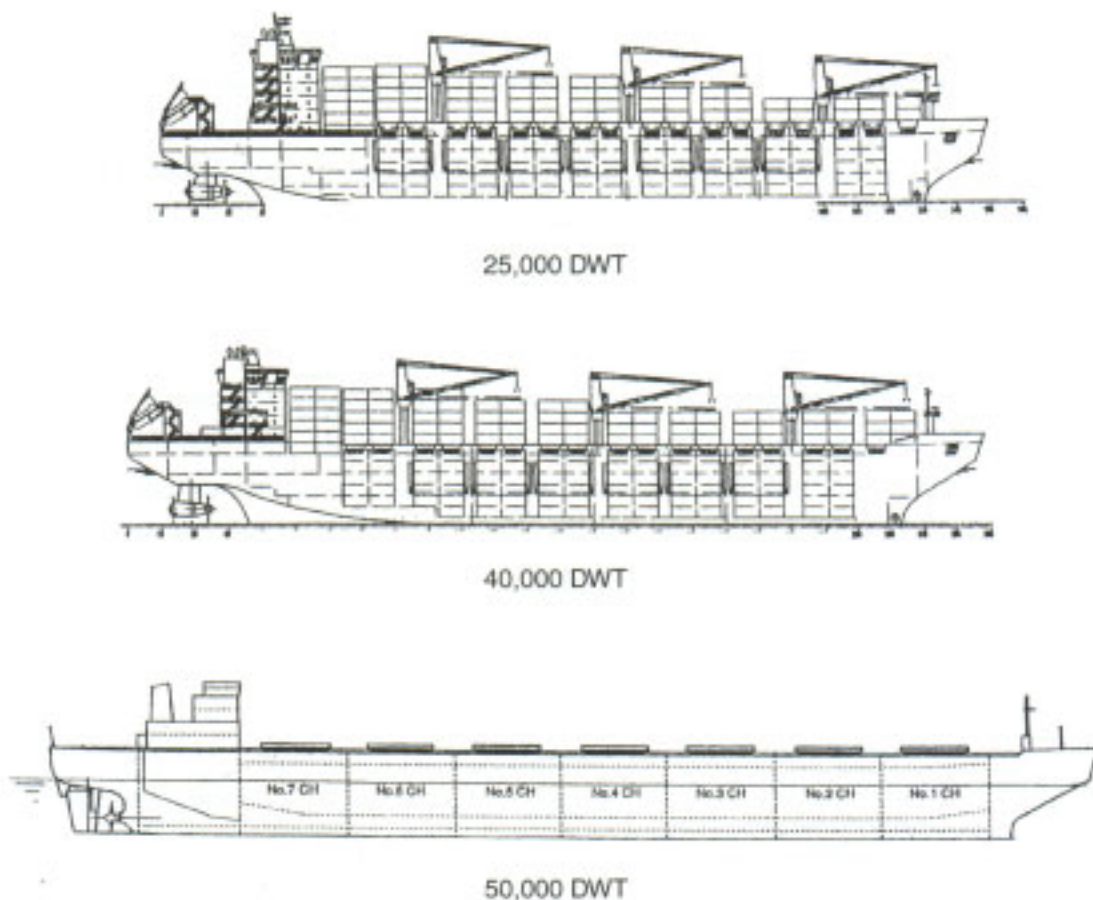

Figure 4.4-2 Three types of ship used in simulation

4. Technological Aspects of NSR Navigation

25,000 DWT icebreaking bulk/container ship (25BC)

This ship has a draft of 9m and is intended for use in the southerly route and in the regional east and west routes. The 25BC was designed to possess the same icebreaking capability as 40,000DWT ship and to be capable of unescorted navigation for up to eight months. The ship is capable of both bulk and container shipping and features the DAS with Azipod as the propulsion system. Lpp is approximately 2m shorter and the breadth is 2m smaller than those of 40,000DWT, to support cargo capacity requirements and hull girder strength.

40,000 DWT icebreaking bulk/container ship (40BC)

The 40BC possesses greater draft and beam than the 25BC. It is designed for the northerly route, with a draft of 12.5m, 40,000 DWT and Azipod propulsion system. As mentioned above, icebreaking capability is the same as that of the 25BC.

50,000 DWT icebreaking bulk carrier (50BC)

This vessel was developed in the JANSROP, organized by the Ship & Ocean Foundation. The ship can continuously break level ice of 1.2m thick at a speed of 3 knots and attain to 17 knots in open sea with sea margin of 15%. Whereas in the above 25BC and 40BC the emphasis is placed on icebreaking performance, the 50BC is designed for high performance in open water, and its main engine output is determined by power requirement in open water. The propulsion system is conventional, with fixed-blade propeller.

Ice condition data

The ice and environmental data used in the simulation were historical data, gathered along the NSR for the past 38 years from 1953 through 1990 and supplied by AARI. The data consisted of eighteen parameters such as ice thickness and ice concentration, and comprise the monthly average data for each 20 nautical mile segment in specified years along the routes. Details on the structure of data are provided in Appendix 5-2.

Cost tables

To calculate ship operational costs, a wide range of cost data are required, including building prices, capital costs, crewing costs, fuel unit/total costs, fees and tariffs. The Nippon Yusen Kabushikigaisya (NYK) line kindly developed ship operational cost tables reflecting recent trends. The study was conducted using the following cost parameters (Table 4.4-5).

Capital cost:

Capital costs for a newly built ship consist of a loan repayment of initial investments that are the sum of building price and initial miscellaneous costs. A ship owner supposed the amortization in 15 years to be at 7% interest per year with level payment. The initial miscellaneous costs included additional costs of a newly building ship, such as interest during the building stage and equipment/deposits newly furnished for navigation, and were predetermined as 3% of a ship price.

Crewing cost:

The number of crews are 24 for both 25BC and 40BC and 25 for 50BC.

Maintenance costs:

For maintenance costs, average annual maintenance costs for the first five years after the construction were adopted. They were based on the actual expenses in the last few years obtained for ships of the same class, and include repairs, replenishment of parts and stocks and lubrication oils, etc.

Insurance costs:

INSROP tried to find a clear answer to the question of insurance rates but was unable to obtain conclusive information. Because the insurance market does not react to hypothetical insurance problems,

insurance costs could not be calculated directly. However, the insurance industry is quite positive when proposals for new business are raised, so it is clear that insurance systems will soon be available for NSR operations. For risk assessment, insurers demand reliable and authentic databases of NSR operations as well as survey data on salvage operations in the event of accidents. Inquiries from a wide range of underwriters would also have to be answered. INSRROP activities and the results made a step toward fulfillment of the basic demands of the insurance market. According to INSRROP's report, however, further experimental voyages will be vital in compiling operation data into a convincing database (Ostreg et al., 1999). Until a complete picture can be formed, insurance costs cannot be calculated on the basis of the previous business results. Clearly, risk levels in Arctic navigation are bound to be higher than in routes passing through the Suez Canal. The ship insurance is usually assigned to P&I (Protection and Indemnity) and H&M (Hull and Machinery). P&I insurance, including cargo insurance, depends on a ship size and a type of cargo, and H&M insurance compiles with the ship price, taking account for the estimated damage rate. Unfortunately Russia has published no official data of the rate of damages. H&M insurance was then estimated assuming the annual sinking rate in the NSR as 0.1%. H&M fell ultimately in the range of 1.0-2.9 US\$/GT. P&I insurance would amount to a further \$8/GT, based on INSRROP report, and package insurance covering P&I and H&M was set at a round figure of 10US\$/GT. This figure is twice the comparable insurance rate prevailing in shipping via the Suez route.

Fuel costs:

Bunker oil prices have fluctuated in the last few years. The heavy fuel oil of 380cSt was assumed to be the fuel, and the average price for the last five years, 91US\$/ton, was adopted.

Table 4.4-5 Cost table for the three ships in the simulation

Cost component	Unit	25BC	40BC	50BC
Building price	Million US\$	57	66	30
Capital cost	Million US\$ /year	6.45	7.46	3.39
Icebreaker fee				
Northerly route, summer	US\$/GT		7.11	6.83
Southerly route, summer	US\$/GT	7.36		
Regional east route, summer	US\$/GT	4.78		
Regional west route, summer	US\$/GT	4.78		
Northerly route, winter	US\$/GT		6.89	6.56
Southerly route, winter	US\$/GT	7.14		
Regional east and west routewestern routes, winter	US\$/GT	7.14		
Ice pilot fee				
Northerly route	US\$/day		672	672
Southerly route	US\$/day	672		
East route	US\$/day	672		
West route	US\$/day	336		
Crewing cost	US\$/day	4.21	4.21	4.38
Maintenance cost	1,000US\$/year	473	493	560
Insurance				
NSR	US\$/GT/year	10.0	10.0	10.0
	1,000US\$/year	210	226	310
Suez route	US\$/GT/year	5.7	5.5	4.8
	1,000US\$/year	119.7	124.3	148.8
Fuel unit cost	US\$/t	91	91	91
Port dues				
Hamburg (6 days)	1,000US\$/entry into port	78.2	84.2	113.1
Dikson (4 days)	1,000US\$/entry into port	19.2		
Tiksi (4 days)	1,000US\$/entry into port	19.2		
Yokohama (6 days)	1,000US\$/entry into port	44.5	47.4	59.7
Suez Canal transit tolls	1,000US\$/entry into port	122	127	139
Number of crew	person	24	24	25
Gross tonnage	GT	21,000	22,600	31,000

4. Technological Aspects of NSR Navigation

Port costs:

The port costs are entailed at each call for port for the use of tug boats and harbor facilities and for cargo handling. These vary widely from port to port and by type of cargo. In this simulation, the cargo was assumed to be bulk cargo such as grain and plastics chips. Four ports, Yokohama, Hamburg, Dikson and Tiksi were chosen as departure/destination ports. The port costs at Yokohama and Hamburg were suggested by the NYK line and those at Dikson and Tiksi were referred from INSROP report (WP-128).

Transit fees on the Suez Canal:

The transit tolls in the Suez Canal were based on the Suez Canal Tonnage and are dependent on type of vessel and carrying capacity. The tolls were estimated by the use of the correlation data between GTs for bulk carriers and their Suez Canal tonnages.

NSR fees (transit fees):

Transit dues must be paid to pass through the NSR. These transit fees include icebreaker escort fees, which are charged per voyage and are regarded as a flat-rate fee, regardless of the frequency of icebreaker escort. In fact, the transit dues must be paid even if no ice is encountered and no icebreaker service is required. The icebreaker escort fee referenced in Table 4.4-6 was cited from the WP-128. The fee is a function of gross tonnage, ice class, season and area of operations, and is specified up to 20,000GT. The cost per GT decreases as GT increases. Surprisingly, summer fees are higher than winter fees, even though frequency of icebreaker support is obviously much higher in winter. It must be noted that final transit fees are subject to negotiation with MSC, which provides the icebreaking services, so the following table should be taken as an approximation only. The values in Table 4.4-5 are the transit fees extrapolated from Table 4.4-6 for the three ships in the simulation. The tariff rate for the 50BC is raised by 10% from the extrapolated value, taking account of the inferiority of icebreaking capability in comparison with other vessels.

Table 4.4-6 Icebreaker Tariff (transit fees)

Ice class	Registered gross tonnage (GT)		Cost of leading (US\$/GT)		
			Summer		Winter
	Above	Below	Entire NSR	Part of NSR	
Icebreaker	5,001	6,000	7.26	4.36	6.53
	10,001	11,000	6.58	3.95	5.92
	19,001	20,001	5.49	3.29	4.94
ULA	5,001	6,000	9.98	6.49	9.73
	10,001	11,000	9.04	5.88	8.82
	19,001	20,000	7.54	4.90	7.36
UL	5,001	6,000	18.15	11.80	17.70
	10,001	11,000	16.44	10.68	16.03
	19,001	20,000	13.72	8.92	13.37
L1	5,001	6,000	22.69	15.88	23.82
	10,001	11,000	20.55	14.38	21.58
	19,001	20,000	17.15	12.00	18.00

Algorithms for calculating ship speed

The most important aspect of the cost simulation is the determination of ship speed under various types of ice conditions. Knowing the ship's speed makes it possible to determine how many days the vessel will be at sea from port to port, so that most of the shipping expenses can be calculated. To simplify this task, researchers have developed ways of expressing ice condition in terms of a numerical value called an ice numeral, which represents the difficulty of ice navigation. Ice numeral is a concept originally introduced in the "Arctic Ice Regime Shipping System Standards" used by CASPPR. The smaller the ice numeral is, the more difficult the ice conditions are. Under identical ice conditions, a ship with lower icebreaking performance will have a larger its

ice numeral. CASPPR's ice numeral is calibrated so that a value of zero corresponds to ice navigation at a speed of 3 knots. If the ice numeral becomes negative, the waters are judged hazardous for navigation. The relation between the ice numerals and the ship speeds obtained from the experimental voyage of the Kandalaksha reveals that, despite some variance, the ice numeral is a good predictor of ship speed (Figure 4.4-3; Yamaguchi, H., 1995). In this simulation, CASPPR's ice numeral was modified to include the influences of flexural and compression strengths of ice, ridge size and ridge distribution. To distinguish this numeral from the Canadian numeral, the numeral was named "ice index". The ice index is calculated by

$$I = I_A + I_B + I_C$$

Where

I_A = Basic ice parameter of ice thickness, ice age, and ice concentration

I_B = Ridge parameter of ridge sail height and ridge density

I_C = Strength parameter of flexural and compression strengths of ice

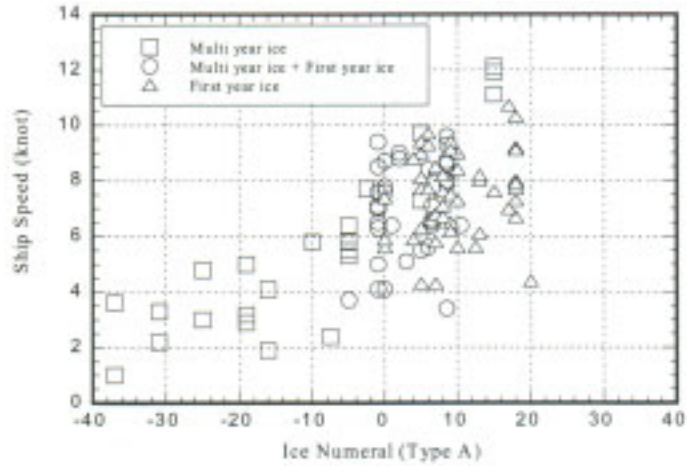

Figure 4.4-3 Correlation between ship speed and ice numeral obtained by the full-scale tests with the Kandalaksha

Normally the correlation between the ice numeral and ship speed is gleaned from operational data. Since no data is available for ships in the conceptual design stage, the correlations between the ice indexes and the three types of ship in the simulation were derived theoretically. In these calculations, a code developed in the ISNR0P called NEWSIM2 (WP-155) was used to determine ship speed under various ice conditions. Loss of ship speed should be expected due to the presence of ice in waters adjacent to the official Russian NSR, such as the Barents Sea and parts of the Bering Sea. Because data from these waters were not included in the data set provided by AARI, the ice conditions were estimated from NSR data from adjacent waters, in which ship speeds had been obtained. In open waters, a uniform speed was assumed to be attained as shown in Table 4.4-4.

Figure 4.4-4 shows an example of the calculation for 50BC. Because the possible ice conditions corresponding to each ice index are numerous, a range of ship speeds is given for each ice index. The discrete probability distribution of the ship speed corresponding to every two pitches of ice index was then developed as shown in the figure, where the ship speed probability distribution for a certain ice index was indicated in five speed-levels. Once the relation between ice index and speed is known, the distribution of ship speeds can be easily determined following a flow chart as shown in Figure 4.4-5, where the data were utilized for a given year and month in each

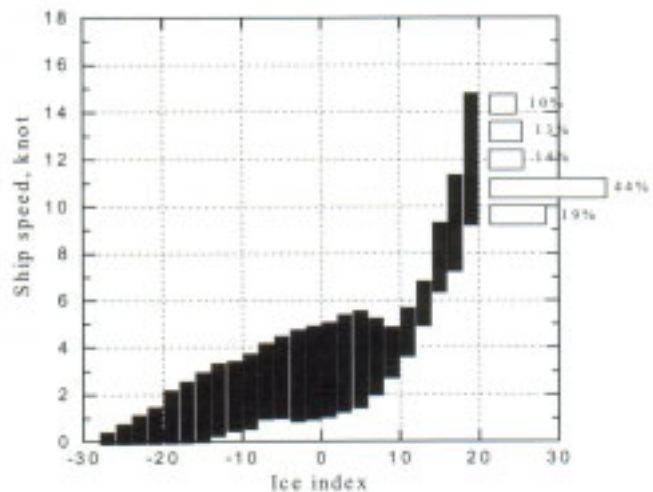

Figure 4.4-4 Ship speed distribution and ice index for 50BC

4. Technological Aspects of NSR Navigation

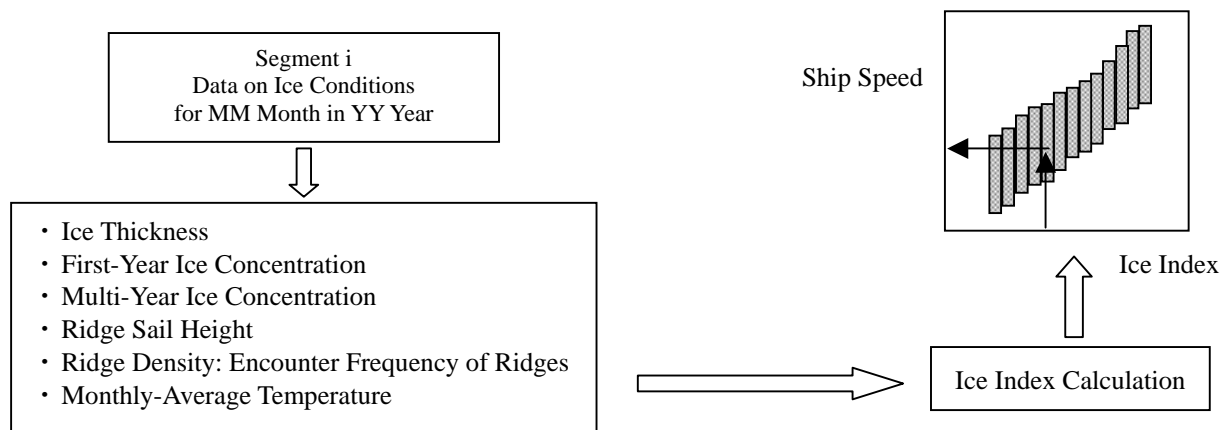

Figure 4.4-5 flow chart for calculation of ship speed distribution

20NM segment of the route. In this way the hours under way in each segment can be obtained. Through the repeated calculation of hours under way in each segment, the distribution of the running days at sea can be derived for the entire route. Ship speed under icebreaker escort was assumed to be the same as that of the icebreaker, and the ship speed was calculated using the ice index derived for the Arktika. Appendix 5-2 shows the correlation between ice index and the ship speeds of the icebreaker and three types of ship used in the simulation.

Simulation program

The simulation calculations of shipping costs were conducted for all combinations of four routes and three ship types. The Russian data were used to specify ice conditions in the NSR, defined by segment, year and month. Each ship left the port of Yokohama in a specified month and year and passed in succession through approximately 130 segments in the NSR. The time to pass through each segment was calculated and costs arising in each segment were derived in a series of repeated calculations. Although the algorithms of the calculation are simple, the colossal data that must be processed in this simulation required a special suite of application software. Three modes of navigation were treated, which depended on the presence or absence of an icebreaker escort.

Navigation modes and the decision to use an icebreaker escort

If the ice index is sufficiently high, ice conditions are favorable enough that ships may navigate the NSR unescorted, even if some ice is present. This mode is called independent mode. As ice conditions deteriorate the ice index drops, obliging icebreaking cargo ships to travel under icebreaker escort. This second scenario is called escort mode. The point on the ice index at which icebreaker support becomes necessary, called IN_c , is derived from the relation between average ship speed and ice index. Icebreaker support is deemed necessary when average ship speed falls to 3 knots, and this point therefore becomes IN_c . IN_c is -4 for 25BC and 40BC and -1 for 50BC. It is assumed that an icebreaker can escort a cargo ship without any standby time at the starting point of the route segment where the escort is requested. Modern satellites have enabled remarkable progress in technology for sea ice monitoring, so that icebreaker escorts can be arranged well in advance of voyages. Icebreaker escort is assumed to be provided in units of one day, and average speed is assumed to be 10 knots. Once escort begins, the computer code searches escort mode segments for the next 12 segments (240NM, including the segment in which escort began), and if the computer finds any segment less than IN_c , the escort is continued (this process is called the “watching mode”). When no escort mode segment is found in the next 12

segments, escort mode can be switched into independent mode at the next segment. As mentioned above, the ship's speed under icebreaker escort is derived from the relation between ice index and ship speed of an escorting icebreaker. The horsepower of the three cargo ships in channels opened by a leading icebreaker was assumed to be 10% higher than in open water, and their fuel expenses were calculated on this basis.

Calculation of shipping cost

The index generally used to calculate operational costs is the freight rate. Freight rate is the sum of yearly average cost per ton of cargo and an anticipated profit per year. For example, the freight rate for cereal shipped to Japan from the Gulf of Mexico is expressed as 12 US\$/t. As a ship operational cost often varies considerably with season and year, if the ordinary approach is applied to operational cost estimation for the NSR, no definite data will be available for operational costs in each month and each route segment. It is assumed, therefore, that every voyage starts at the beginning of a month and the monthly costs are then calculated for a single voyage. On this monthly data basis, the freight rate is derived from the annual cost and a number of possible voyages. In the cost simulations, the freight rate does not include a profit margin. Full-load voyages are assumed in all cases. Cost evaluation is carried out in one of the two following ways.

Monthly voyage simulation

To examine trends in ship speed in each month and each route segment, the monthly costs for a single voyage were calculated. In each case, Yokohama was used as the starting point and Hamburg the destination, and the ship was assumed to leave port at the beginning of the month as stated above. In voyages of longer than one month, data of the following month was used, except data on ice conditions, which were taken from the month in which the ship left port for the sake of continuity. These single-voyage simulations based on monthly data for each year was named the monthly voyage simulation (MVS). In the regional routes, Dikson and Tiksi were used as the starting points. In these calculations, cost data (Table 4.4-5) provided on a yearly basis were divided into monthly or daily costs as appropriate. The computer program calculated the hours under way in each segment, which yielded the costs required in the segment (Figure 4.4-6).

Annual serial voyage simulation

The freight rate is usually calculated from the costs required over a specified period and the total transporting cargo volume as their ratio, usually on an annual basis. In these calculations, a serial voyage operation between Yokohama and Hamburg for a year was simulated, and the voyage started at Yokohama on January 1. The anchoring days at each port are selected from the actual operation data. At the end of the year, if the ship was in the middle of a journey, the time was extended until the ship reached port, and the equivalent number of voyages per year was calculated. When the month changed in the middle of a simulation, the data of the new month were used. This simulation was called the annual serial voyage simulation (ASVS). In selecting the optimum route for the voyage, which included alternative NSR routes as well as conventional routes via the Suez Canal in severe ice conditions, the final freight rate was deduced from the annual serial voyage simulation. A flow chart of the calculation program appears in Figure 4.4-7.

Table 4.4-7 Discounted rates for NSR transit fees

Entire NSR			Extrapolated fee	With 26% discount
			\$/GT	\$/GT
25BC	Summer	(July to October)	7.36	5.45
	Winter	(November to June)	7.14	5.28
40BC	Summer	(July to October)	7.11	5.26
	Winter	(November to June)	6.89	5.10
50BC	Summer	(July to October)	6.83	5.05
	Winter	(November to June)	6.56	4.86
NSR regional routes			Extrapolated fee	With 26% discount
			\$/GT	\$/GT
25BC	Summer	(July to October)	4.78	3.54
	Winter	(November to June)	7.14	5.28

4. Technological Aspects of NSR Navigation

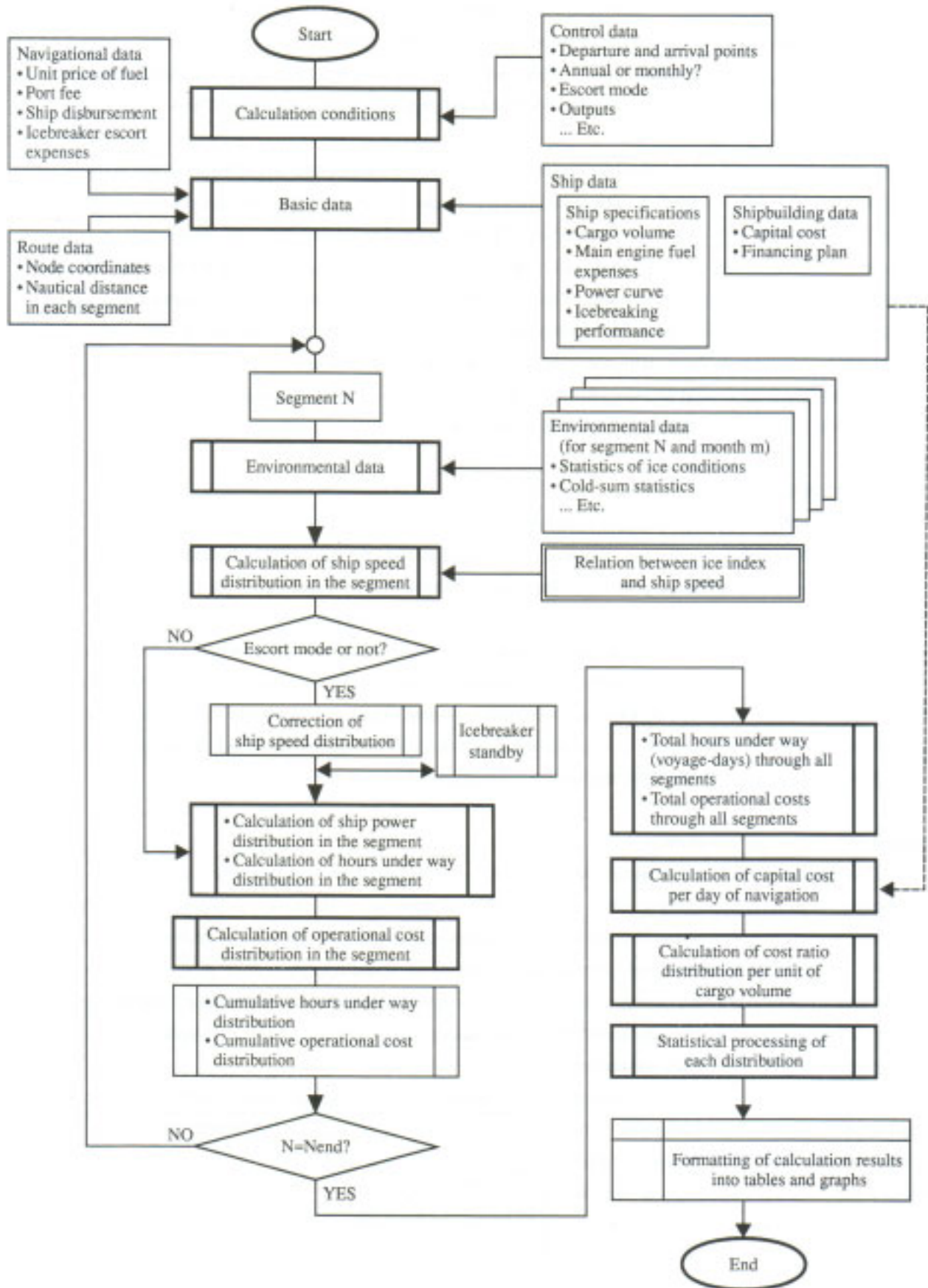

Figure 4.4-6 Flow chart of monthly voyage simulation

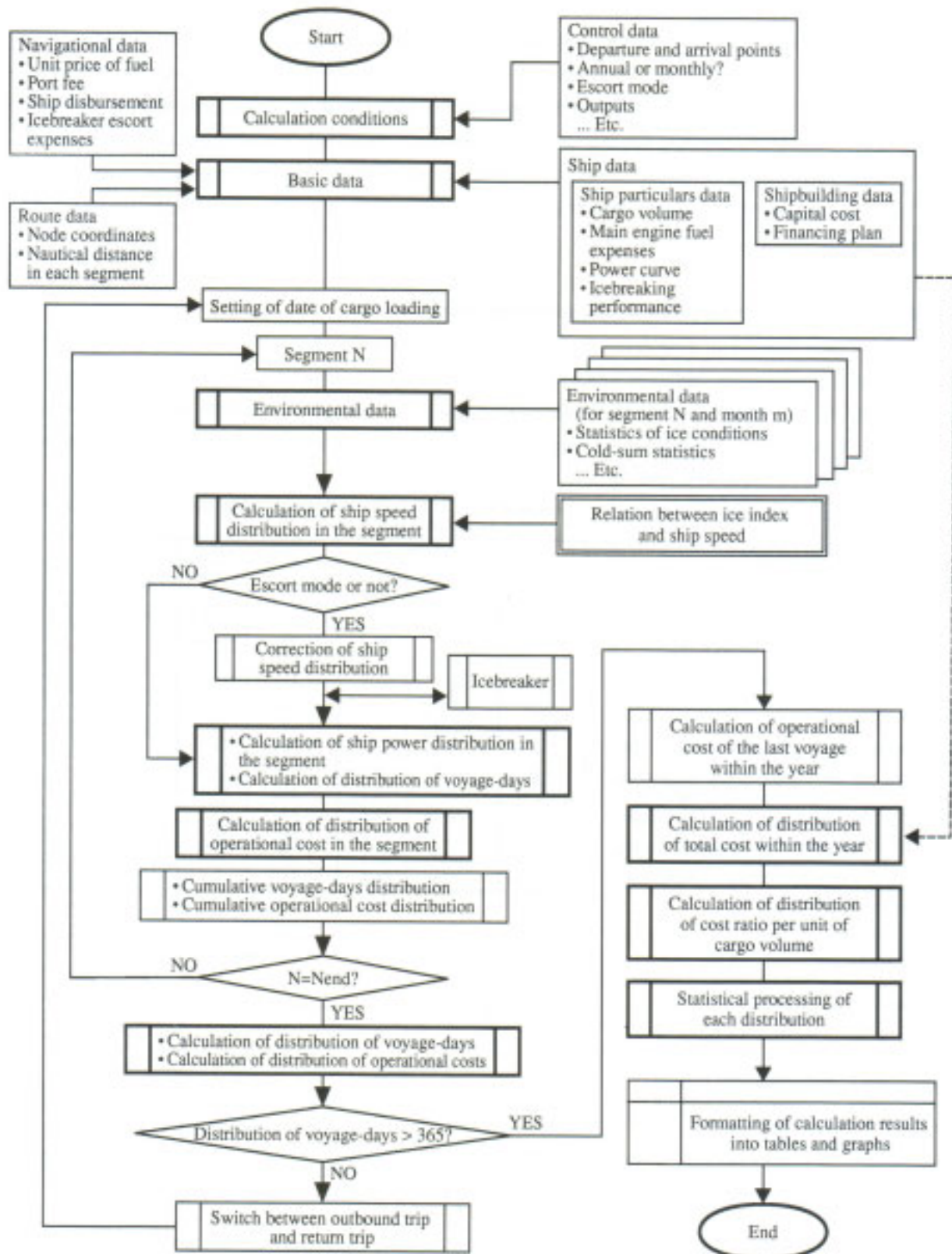

Figure 4.4-7 Flow chart of annual serial voyage simulation

4. Technological Aspects of NSR Navigation

Simulation results

Discussions on NSR fees (transit fees)

NSR transit fees are a major component of total operational cost. When high transit fees are applied, the NSR cannot compete successfully with the route via the Suez Canal. A MVS was therefore run to find out what an appropriate level of transit fees would be, before conducting a series of simulations. Through the comparison of the operational costs between the NSR and the route via the Suez Canal, it was assumed that the NSR dues should possess the primary requisite that the NSR operation was economically superior to the Suez one for half a year with the 40BC in service. Reduction of 26% (Table 4.4-7) from the extrapolated fee for large ships (Table 4.4-6) was found to satisfy this requirement. The following simulation was conducted on the basis of this 26% reduction in NSR transit fees.

Results by transit route (northerly route, southerly route) (MVS)

The 40BC and 50BC with deep drafts are designed for the northerly route while the 25BC with a shallow draft is aimed primarily at the shallower southerly route. MVS was carried out using data on ice conditions from 1957 to 1990. As one example, Table 4.4-8 indicates the number of voyage-days in each month, using data in 1979 and 1980. Because the ice index provides a probability distribution for ship speeds, the number of running days at sea is also obtained in a form of distribution, though the range of variance is narrow. The table indicates the average values as well as the 1% min. and 1% max. The notations, 1% min. and 1% max. in the figures mean the value under which the probability of occurrence at 1% and the value corresponding to the probability at 99%, respectively. Average voyage- days by month for the 25BC, 40BC and 50BC and their breakdowns are shown in Figure 4.4-9. For the 40BC, the longest voyage occurred in March, at 44.1 days (26.8

Table 4.4-8 Total costs and freight rates per voyage for transit route, by month

Month	25BC		40BC		50BC	
	Total cost (1,000US\$)	Freight rate (US\$/t)	Total cost (1,000US\$)	Freight rate (US\$/t)	Total cost (1,000US\$)	Freight rate (US\$/t)
January	1,433	66.7	1,599	44.4	1,082	23.0
February	1,444	67.2	1,552	43.1	1,064	22.6
March	1,438	66.9	1,517	42.1	1,074	22.9
April	1,388	64.6	1,474	40.9	1,049	22.3
May	1,292	60.1	1,399	38.9	1,008	21.4
June	1,140	53.0	1,241	34.5	907	19.3
July	1,184	55.1	1,302	36.2	959	20.4
August	1,100	51.2	1,242	34.5	923	19.6
September	1,067	49.6	1,194	33.2	890	18.9
October	1,159	53.9	1,250	34.7	918	19.5
November	1,357	63.1	1,399	38.9	1,041	22.1
December	1,423	66.2	1,527	42.4	1,039	22.1

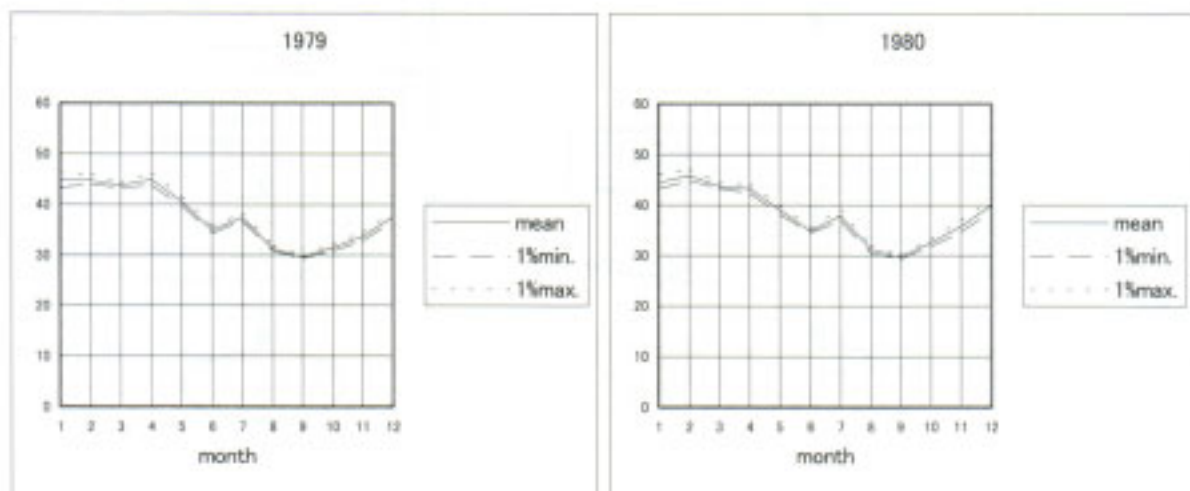

Figure 4.4-8 Example of voyage-days for 40BC (1979, 1980)

days in the NSR); the shortest voyage was 30.7 days, in September (15.7 days in the NSR). For the 50BC, the longest voyage was also in March, taking 42.7 days (27.3 days in the NSR); the shortest voyage was 28.8 days, again in September (16.1 days in the NSR). Although the 40BC takes slightly less time to navigate the NSR than the 50BC does, in total voyage-days the 50BC's voyage is about two days shorter. This is because the 50BC is about 2.5 knots faster than the 40BC in open water, suggesting the importance of open-water performance for overall profitability. The number of days of icebreaker escort depends on the severity of the ice conditions. The 25BC and 40BC possess roughly equal icebreaking capability. When the northerly and southerly routes are compared, the 25BC requires more days of icebreaker escort in the southerly route than does the 40BC from December to May, whereas the 40BC requires more icebreaker escort than the 25BC does from June to November. The selection of route is highly dependent on the season. In the winter, the landfast ice extending along the coast makes ice conditions severe for navigation; at this time of year, operations are more convenient along the northerly route, since ships navigate in the marginal waters of landfast ice, abundant in polynyas. In the summer, open water can be found along the coast, making the coastal route more advantageous. Changes in average sea speeds in the major NSR waters by month are shown for the 50BC in Figure 4.4-9. During the winter months from December to May, sea speed in all regions is in the range of 4-7 knots, with sea speeds ranging somewhat higher in the Laptev Sea. In the winter, as the number of days on which icebreaker escort is required increases, the speed of the icebreaker becomes the dominant factor. Ice conditions are easiest in the summer months from August to October, enabling the 50BC to achieve speeds of 9-14 knots. In the East Siberian Sea, sea speeds are found to be slower in the most cases than in other regions. As shown in Appendix 5-2, the results for the 25BC and 40BC are not dramatically different than those for the 50BC. The dependences on operation month and type of ship were examined by the freight rates defined by the ratio of the operational costs for each voyage to transported cargo tonnage (Table 4.4-8). Capital cost accounted for the largest proportion of operational cost (see Appendix 5-2). The lowest operational cost per voyage was that of the 50BC, at around \$890,000-1,080,000, while the most expensive was the 40BC's, at \$1,190,000-1,600,000. In these cost calculations, voyage-days, sea speed, operational cost, etc. were averages for 30 years or so, based on the sea ice data from 1957 to 1990. The number of voyage-days per voyage includes three days for loading and three days for unloading at each end. For details of the cost calculations, please see Appendix 5-2.

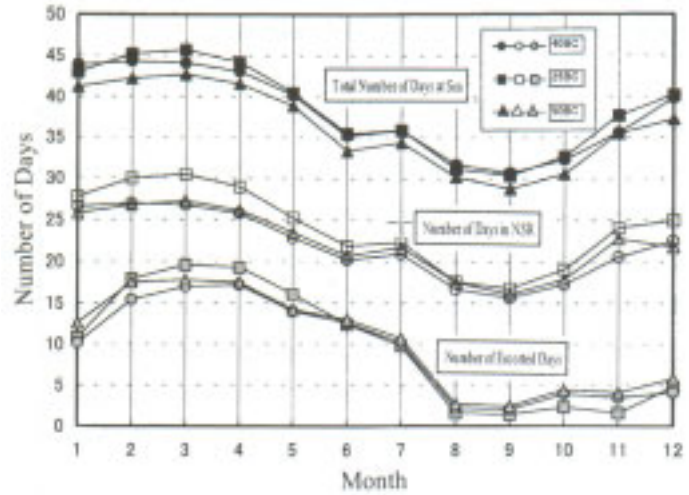

Figure 4.4-9 Average number of voyage-days for each of the three ships; full voyage, voyage in NSR and escorted voyage (average values from 1957 to 1990)

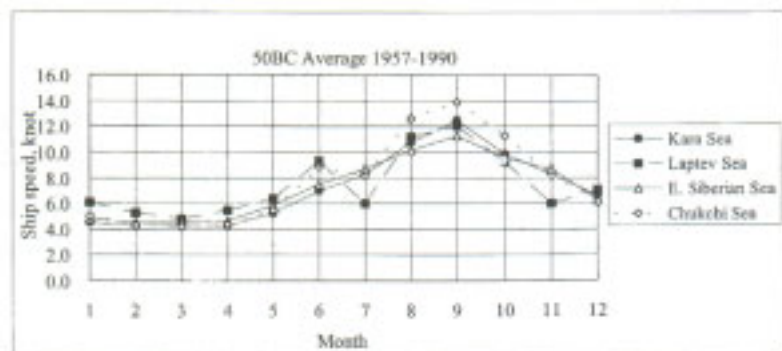

Figure 4.4-10 Monthly changes in average sea speed in major NSR waters (average values through 1957-1990の平均値)

4. Technological Aspects of NSR Navigation

Operational costs on regional routes

The regional west route links Dikson with Hamburg over a distance of 4,020 nautical miles. Its eastern counterpart runs from Tiksi to Yokohama over a distance of 2,397 nautical miles. The former route traverses the NSR only through the Kara Sea, while the latter winds through the Laptev Sea, East Siberian Sea and Chukchi Sea. Because each of these routes runs almost exclusively through shallow coastal waters of the southerly route as described earlier, the simulation for these routes was conducted only for the 25BC with a shallow draft, and the characteristics of each of the regional route operations were clarified.

MSV was adopted as the simulation method, so ice data from 1957 to 1990 were applied, and average monthly values over 30 years were used to calculate monthly changes in number of voyage-days, sea speed and operational costs (Figure 4.4-11, Table 4.4-9). On the eastern route, the number of icebreaker escort days was a relatively long 0.9-11.2 days, indicating the harshness of the ice conditions in the eastern NSR. Because the regional west route crosses only the Kara Sea, the ice conditions on this route are much more moderate, reducing the number of icebreaker escort days to 0.7-2 days; in years of favorable ice conditions, passage with no icebreaker support at all is even possible. In the easier ice conditions, ship speeds are faster in the regional west route. Sea speeds only fall down into the 4-6 knots range from February to May; during the rest of the year, the speeds of around 10 knots are possible. Table 4.4-9 shows the freight rates by month, defined by the ratio of total cost per voyage to transported cargo volume. The total cost per voyage was found in the range of US\$704,000-898,000 for the regional east route and \$457,000-656,000 for the regional west route. For details on sea speeds and operational costs for each route, please see Appendix 5-2.

Table 4.4-9 shows the freight rates by month, defined by the ratio of total cost per voyage to transported cargo volume. The total cost per voyage was found in the range of US\$704,000-898,000 for the regional east route and \$457,000-656,000 for the regional west route. For details on sea speeds and operational costs for each route, please see Appendix 5-2.

Annual operational costs for the seasonal NSR operation

In the winter season, the simulation showed that freight costs tend to be lower on the Suez Canal route than in the NSR. From the practical standpoint, the subject of inquiry was then addressed for possible alternative operations of the NSR or the traditional route, asking how much freight costs could be reduced by switching between the Suez Canal route and the NSR in response to the ice conditions. The study focused on the northerly route, and the vessels used were the 40BC and 50BC. This scenario well reflects the economic realities: even when the NSR is commercialized, for the foreseeable future it will have to be used in alternation with the Suez Canal route. Key indexes should therefore be found for decision-making of route selection. As one of the key indexes, the cumulative ice index was chosen in this study, which indicated the level of difficulty of navigation

Table 4.4-9 Total cost per voyage and freight rate by month (regional routes)

Month	25BC, regional east route		25BC, regional west route	
	Total cost (1,000US\$)	Freight rate (US\$/t)	Total cost (1,000US\$)	Freight rate (US\$/t)
January	1,433	66.7	1,599	44.4
February	1,444	67.2	1,552	43.1
March	1,438	66.9	1,517	42.1
April	1,388	64.6	1,474	40.9
May	1,292	60.1	1,399	38.9
June	1,140	53.0	1,241	34.5
July	1,184	55.1	1,302	36.2
August	1,100	51.2	1,242	34.5
September	1,067	49.6	1,194	33.2
October	1,159	53.9	1,250	34.7
November	1,357	63.1	1,399	38.9
December	1,423	66.2	1,527	42.4

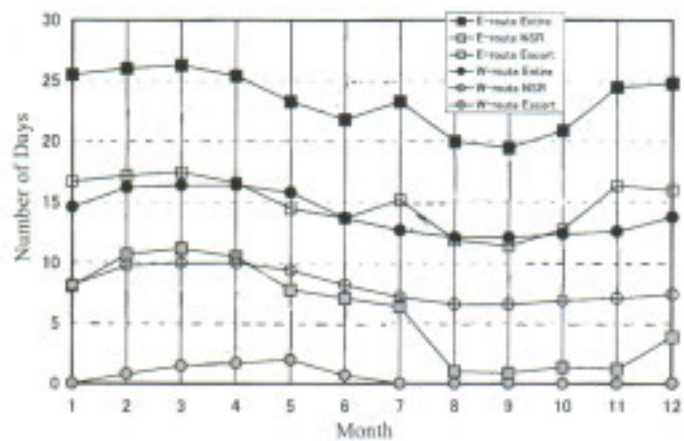

Figure 4.4-11 Average number of voyage-days by month on the regional east and west routes and their breakdowns (average values through 1957-1990)

in the NSR. The MVS method was used for the 40BC to determine the correlation between cumulative ice index for ten years from 1980 to 1989 and the freight costs. Despite fairly wide variance, it became clear that a correlation exists between the ice index and freight costs. Because freight costs for the 40BC on the Suez Canal route are US\$39.60/t, the Canal route is more economical than the NSR in the case that the cumulative ice index is lower than -26,000. Table 4.4-10 shows the cumulative ice index by month for the ten-year period 1980-1989, where the hatched columns indicate unfavorable conditions for the NSR with cumulative ice indexes lower than -26,000. When the 40BC leaves the port of Hamburg for Yokohama between February and May, the Suez Canal route is preferable. According to this route-switching criterion, the ASVS was run for the 40BC and 50BC, based on the data for the years 1960, 1970 and 1980. As an example of these calculations, the results for 1980 are shown below (Tables 4.4-11 and 4.4-12). Each voyage includes each three days for unloading and loading at each port.

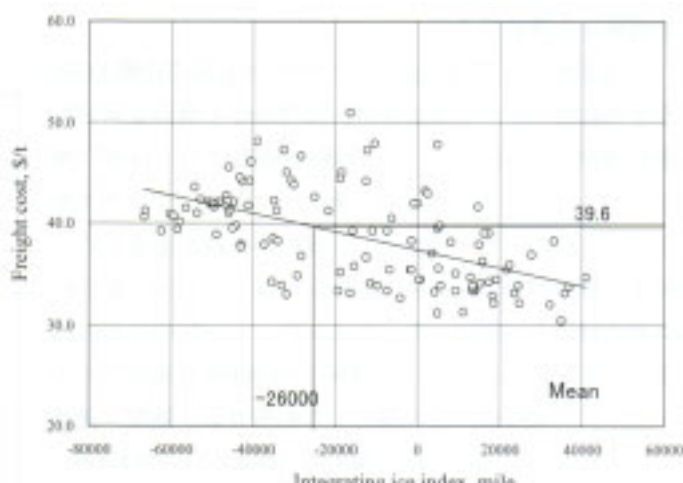

Figure 4.4-12 Correlation between the cumulative ice index for the 40BC and freight costs

Table 4.4-13 shows the summary of results for 1960, 1970 and 1980. Freight rates for a 40BC passing through the Suez Canal three or four times per year range between \$35.60/t and \$36.20/t, while the corresponding range for the 50BC is \$20.10-20.70/t. Due to the superior performance of the 50BC in capital cost, cargo capacity and sea speed in open water, the 50BC has the better freight rates than the 40BC. In this simulation it was assumed that icebreaker escort would always be available immediately by request and the flat rate was adopted. The 50BC could therefore be superior to the 40BC, although the 40BC possesses excellent icebreaking capability.

Table 4.4-10 40BC cumulative ice index by month for the years 1980-1989

year month	1980	1981	1982	1983	1984	1985	1986	1987	1988	1989	1990
1	-40906	-30608	-12573	-10532	-39056	-18914	-32497	-16310	-30065	-12142	-13460
2	-46008	-50524	-44641	-31872	-46470	-54445	-43169	-59402	-49435	-34429	-20598
3	-53759	-50823	-35042	-56387	-42612	-52777	-46153	-44126	-49955	-25121	-34944
4	-49678	-58413	-60327	-57841	-40478	-66545	-48491	-66268	-62363	-41260	-36330
5	-35284	-37292	-43012	-42940	-28454	-49060	-45855	-45671	-44935	-33957	-5639
6	-33148	-9731	-29388	-28240	-10974	-31804	-18858	-19403	-35439	-16488	-12603
7	-7320	-15633	-1753	-15956	-6732	-7501	8077	-11541	-12660	-1442	19493
8	13996	18182	27901	40902	33190	24610	21724	22378	13436	23730	42370
9	24675	365	36849	35692	32166	4908	-4198	10982	18622	35033	52651
10	684	4794	17227	13410	9137	19020	3622	15129	5797	4312	38756
11	-1630	14770	9128	4977	17314	15853	16000	15854	12837	13509	31671
12	-21730	1874	-6130	-18624	5295	15019	-45	-895	2284	4674	-897

4. Technological Aspects of NSR Navigation

Table 4.4-11 Seasonal operation of NSR (40BC, ASVS, 1980)

Voyage No		1	2	3	4	5	6	7	8	9	10
Departure-Arrival		0101-0213	0214-0326	0327-0506	0507-0616	0617-0725	0726-0826	0827-0925	0926-1028	1029-1203	1204-0113
Route		NSR	via Suez	via Suez	via Suez	NSR	NSR	NSR	NSR	NSR	NSR
Direction		E->W	W->E	E->W	W->E	E->W	W->E	E->W	W->E	E->W	W->E
Voyage-days	Days	44	41	41	41	38	31	30	33	36	40
Escort days	Days	19				10	4	3	6	6	11
Voyage total cost	1,000US\$	1,521	1,428	1,428	1,428	1,408	1,203	1,155	1,241	1,378	1,493
* Capital cost	1,000US\$	893	824	824	824	780	638	608	665	730	824
* Operational cost	1,000US\$	270	238	238	238	236	193	184	201	221	249
* Port fee	1,000US\$	67	67	67	67	67	67	67	67	67	67
* Fuel cost	1,000US\$	162	172	172	172	202	181	175	183	240	229
* Icebreaker fee	1,000US\$	130				123	123	122	124	120	124
Suez Canal fee	1,000US\$		127	127	127						

Table 4.4-12 Seasonal operation of NSR (50BC, ASVS, 1980)

Voyage No		1	2	3	4	5	6	7	8	9	10	11
Departure-Arrival		0101-0212	0213-0320	0321-0425	0426-0531	0601-0704	0705-0811	0812-0909	0910-1007	1008-1108	1109-1217	1218-0125
Route		NSR	via Suez	via Suez	via Suez	NSR	NSR	NSR	NSR	NSR	NSR	NSR
Direction		E->W	W->E	E->W	W->E	E->W	W->E	E->W	W->E	E->W	W->E	E->W
Voyage-days	Days	42.4	36.0	36.0	36.0	33.0	37.5	28.6	27.9	31.6	38.2	38.1
Escort days	Days	19.4				13.8	9.2	4.3	2.7	5.8	8.8	17.4
Voyage total cost	1,000US\$	1,079	1,055	1,055	1,055	892	1,049	869	860	931	1,066	987
* Capital cost	1,000US\$	394	329	329	329	307	348	266	259	294	355	354
* Operational cost	1,000US\$	287	224	224	224	223	253	194	189	214	258	258
* Port fee	1,000US\$	92	92	92	92	92	92	92	92	92	92	92
* Fuel cost	1,000US\$	140	271	271	271	108	190	156	159	168	203	118
* Icebreaker fee	1,000US\$	166				162	165	162	160	163	158	164
Suez Canal fee	1,000US\$		139	139	139							

Table 4.4-13 Comparison of total annual costs for the 40BC and 50BC (1960, 1970 and 1980)

Year		1960		1970		1980		
Ship type		40BC	50BC	40BC	50BC	40BC	50BC	
	Cargo tonnage	tons	36,000	47,000	36,000	47,000	36,000	47,000
NSR	Number of voyages		6.6	6.5	6.5	6.1	6.7	7.4
	Total cargo tonnage	tons	238,000	304,000	235,000	288,000	240,000	346,000
	Total cost	1,000US\$	8,171	5,785	8,129	5,642	8,114	6,640
	Freight cost	US\$/t	34.3	19.0	34.6	19.6	33.8	19.2
Suez Canal	Number of voyages		3	4	3	4	3	3
	Total cargo tonnage	tons	108,000	188,000	108,000	188,000	108,000	141,000
	Total cost	1,000US\$	4,281	4,222	4,281	4,222	4,281	3,167
	Freight cost	US\$/t	39.6	22.5	39.6	22.5	39.6	22.5
Total (NSR + Suez)	Total cargo tonnage	tons	346,000	492,000	343,000	476,000	348,000	487,000
	Total cost	1,000US\$	12,452	10,007	12,410	9,864	12,395	9,807
	Freight cost	US\$/t	36.0	20.3	36.2	20.7	35.6	20.1

Optimum operation

In the foregoing simulation the Suez Canal route was selected as the most economical for ships leaving port from February to May. In the future, however, as an abundance of satellite data becomes available, it should be possible to obtain an accurate information on ice conditions before entering the NSR. In effect, this means that the results of forecasts can be used reliably to decide when to switch between the Suez Canal route and the NSR, so that the optimum route can be selected in any voyage. Under these conditions for ice information, the study was carried out to examine how far freight rates could be reduced using the 50BC. Once again the ice index was used to determine when to switch between routes; when the ice index fell below -50,000, the Suez Canal route would be selected. Data were obtained from the decade 1980-1989, the results of which are shown in Table 4.4-14. Freight rates were set in the range of US\$20.30-\$21.60/t. To provide an example of optimum switching operation, the results for 1987 appear in Table 4.4-15. In this scenario, the Suez Canal route was selected once and the NSR 9.3 times, for a total of 10.3 voyages. Average ship speed through the NSR was 7.8-13.7 knots. Freight rates for summer navigation alone were calculated at approximately \$18.10/t. Therefore, summer freight rates for icebreaking bulk carriers in the NSR is roughly equal to that of conventional handy-size bulk carriers, while the year-round NSR operation is somewhat more expensive. These results demonstrate that the icebreaking bulk carriers could be competitive to the conventional handy-size bulk carriers. For a breakdown of various costs for a conventional 50,000 DWT bulk carrier in open-water operation, please see Appendix 5-2.

Table 4.4-14 Summary of annual serial voyage simulation for 50BC, 1980-1989

Year			1980	1981	1982	1983	1984
	Cargo tonnage	Tons	47,000	47,000	47,000	47,000	47,000
NSR	Number of voyages	Frequency	8.3	8.1	9.0	8.3	10.0
	Voyage days	Days	293	293	329	293	365
	Total cargo tonnage	Tons	390,100	382,100	421,600	391,000	468,600
	Total cost	1,000US\$	8,071	8,043	8,967	8,121	10,117
	Freight cost	US\$/t	20.7	21.1	21.3	20.8	21.6
Suez Canal route	Number of voyages	Frequency	2	2	1	2	0
	Voyage days	Days	72	72	36	72	0
	Total cargo tonnage	Tons	94,000	94,000	47,000	94,000	0
	Total cost	1,000US\$	2,111	2,111	1,056	2,111	0
	Freight cost	US\$/t	22.5	22.5	22.5	22.5	22.5
Total (NSR + Suez)	Total cargo tonnage	Tons	484,100	476,100	468,600	485,000	468,600
	Total cost	1,000US\$	10,182	10,154	10,023	10,232	10,117
	Freight cost	US\$/t	21.0	21.3	21.4	21.1	21.6

Year			1985	1986	1987	1988	1989
	Cargo tonnage	Tons	47,000	47,000	47,000	47,000	47,000
NSR	Number of voyages	Frequency	8.2	9.8	9.3	8.5	10.5
	Voyage days	Days	293	365	329	293	365
	Total cargo tonnage	Tons	386,300	459,700	437,600	400,900	493,000
	Total cost	1,000US\$	8,132	9,925	9,045	8,122	10,028
	Freight cost	US\$/t	21.1	21.6	20.7	20.3	20.3
Suez Canal route	Number of voyages	Frequency	2	0	1	2	0
	Voyage days	Days	72	0	36	72	0
	Total cargo tonnage	Tons	94,000	0	47,000	94,000	0
	Total cost	1,000US\$	2,111	0	1,056	2,111	0
	Freight cost	US\$/t	22.5	22.5	22.5	22.5	22.5
Total (NSR + Suez)	Total cargo tonnage	Tons	480,300	459,700	484,600	494,900	493,000
	Total cost	1,000US\$	10,243	9,925	10,101	10,232	10,028
	Freight cost	US\$/t	21.3	21.6	20.8	20.7	20.3

4. Technological Aspects of NSR Navigation

Table 4.4-15 Example of annual serial voyage simulation for the 50BC in 1987

Voyage No.		1	2	4	5	6	7	8	9	10	11	12
Departure-Arrival		0101-02 14	0215-03 27	0328-05 02	0503-06 11	0612-07 13	0714-08 12	0813-09 13	0914-10 11	1012-11 12	1113-12 18	1219-01 29
Route		NSR	NSR	via Suez	NSR	NSR	NSR	NSR	NSR	NSR	NSR	NSR
Direction		E->W	W->E	E->W	W->E	E->W	W->E	E->W	W->E	E->W	W->E	E->W
Voyage-days	Days	45	41	36	40	31	30	31	28	31	35	42
Escort days	Days	18	22		16	10	9	3	4	5	6	13
Total cost	1,000US\$	1,151	1,018	1,055	1,037	872	870	949	847	935	1,019	1,122
* Capital cost	1,000US\$	414	380	329	368	289	279	292	259	291	328	390
* Operational cost	1,000US\$	301	276	224	268	210	203	213	188	212	239	284
* Port fee	1,000US\$	92	92	92	92	92	92	92	92	92	92	92
* Fuel cost	1,000US\$	179	102	271	146	122	131	192	146	177	205	195
* Icebreaker fee	1,000US\$	164	168		163	159	165	161	162	162	155	161
Suez Canal fee	1,000US\$			139								
平均船速	1,000US\$	7.8	8.6	17.0	8.9	12.0	12.5	11.8	13.7	11.8	10.2	8.3
Freight cost	US\$/t	24.5	21.7	22.5	22.1	18.6	18.5	20.2	18.0	19.9	21.7	23.9

Conclusions

Capital costs have the most significant impact on the NSR operational costs. Improvement in icebreaking capability of the NSR vessels necessitates an increase in the main engine output and the hull weight, raising capital costs. Annual capital costs per cargo tonnage amount to \$207/t for the 40BC and \$72/t for the 50BC. Capital costs for the 40BC are therefore some three times those of the 50BC. Improvement in icebreaking capability of the 40BC resulted in two times higher building costs than the 50BC. It is worthwhile, then, to look closely at the relationship between capital costs and icebreaking performance. The difference in number of escort days between the 40BC and 50BC is greatest in the winter, but it is only two days and almost none in summer. Undeniably, this difference is affected by one of the assumptions of the simulation—that an icebreaker escort will be available as soon as ship speed falls to 3 knots or lower. This rather strong assumption renders it difficult to use the superior icebreaking performance of the 40BC to full advantage. If the time required to wait for an icebreaker escort is as long as a few days, the superiority of the 40BC becomes more obvious. At present, the icebreaker escort fees charged by Russia are unaffected by the number of escort days required. At present, the Russian authorities propose a flat rate and fully guaranteed icebreaker support in escorting operation. Preferably, under these escort conditions, the NSR cargo vessels would have moderate icebreaking capability and relatively high propulsion performance in open water. Moreover, if the fee for icebreaker escort could be reduced to \$5/GT for the 50BC, as proposed in this simulation, the NSR transit operation with the 50BC class icebreaking bulkers could be sufficiently competitive with the operation of conventional handy-size bulk carriers through the Suez Canal route during the summer months. In terms of year-round operation, even if the NSR is used only seasonally, the cost would be about 10% higher than in the Suez Canal route with conventional handy-size bulk carriers. However, icebreaker escort is required in 70% of the NSR during the winter, and the flat rate for the escort, currently proposed by the Russian government, is unrealistic. On the other hand, in the regional routes it was seen that the 25BC could traverse the NSR virtually year-round with no icebreaker escort. For such operation without icebreaker escort, the present compulsory escort tariff is indefensible. The NSR tariff structure should be determined rationally from comprehensive studies on the NSR operations and trends in the international shipping market.

Going forward, as it focuses more keenly on attracting foreign investment, Russia may choose to provide new icebreaker fleets to cater to the needs of the international shipping market, and to implement a shipping support system that is more closely attuned to market principles. If so, the conclusions reached in these simulations point the way to a more beneficial use of the NSR.

4.5 Environmental Impact and Preservation

4.5.1 Structure of the Arctic Ocean

The oceans, including the Arctic Ocean, play an important role in the diffusion and circulation of environmental pollutants. The Arctic Ocean is being critically examined for the feasibility of exploitation of their natural resources, and there is considerable evidence that global environmental problems will disproportionately impact the Arctic region. If we are to understand the influences of human activities in the Arctic and the response of the Arctic systems to human-induced perturbations, an appreciation of the role of the Arctic Ocean is required. A brief overview of the Arctic Ocean is therefore presented here.

A dominant characteristic of the Arctic Ocean is the year-round presence of a dynamic ice cover. The ice cover in the Arctic Ocean has a profound effect on the air-sea interaction, in particular, heat, mass and momentum transfers. The Arctic Ocean comprises deep central basins at the higher latitudes and several shallow marginal seas; the Chukchi Sea, East Siberian Sea, Laptev Sea, Kara Sea, Barents Sea and Beaufort Sea. As described in Section 3.1.1, the Arctic Ocean is almost a closed ocean, linked to the Pacific Ocean by the narrow Bering Strait and to the Atlantic Ocean by the Canadian Arctic Archipelago, the Fram Strait and the Barents Sea. The broad continental shelf off Siberia that constitutes the NSR, extending from 200 km to as far as 800 km into the ocean, is in most cases no more than 100 m deep. Although these shallow seas account for 36% of the Arctic Ocean's total area, they contain only 2% of the total volume of water of the Arctic Ocean. This region has also freshwater inflow from numerous rivers, with the highest ones in the thawing season of snow.

Vertical circulation occurs in the Arctic by two counterbalancing processes.

- * The inflow of fresh water from Arctic rivers creates density stratification, which blocks the vertical circulation. The freshwater inflow also generates currents that flow from the Arctic Ocean into the North Atlantic Ocean.
- * As heat is lost from the water surface in the winter, sea ice forms. During sea ice formation, salt and impurities are discharged down into water, making the seawater below the sea ice heavier and causing it to sink.

The fundamental features of the currents in the Arctic Ocean vary little throughout the year. The salinity, on the other hand, varies considerably according to the formation and melting of ice. In the upper layer 25-50m, the salinity changes from 2.8% to 3.35%. The temperature is also controlled by the ice dynamics through considerable heat transfer. The latent heat of the sea ice as much as 80kcal/kg plays a major role in this transfer, which is equivalent to 80 ° C change in water temperature.

The movements of water masses at different depths are illustrated in terms of pollution in Figure 4.5-1. Two main features



Figure 4.5-1 The circulation pattern of surface water in the Arctic Ocean

4. Technological Aspects of NSR Navigation

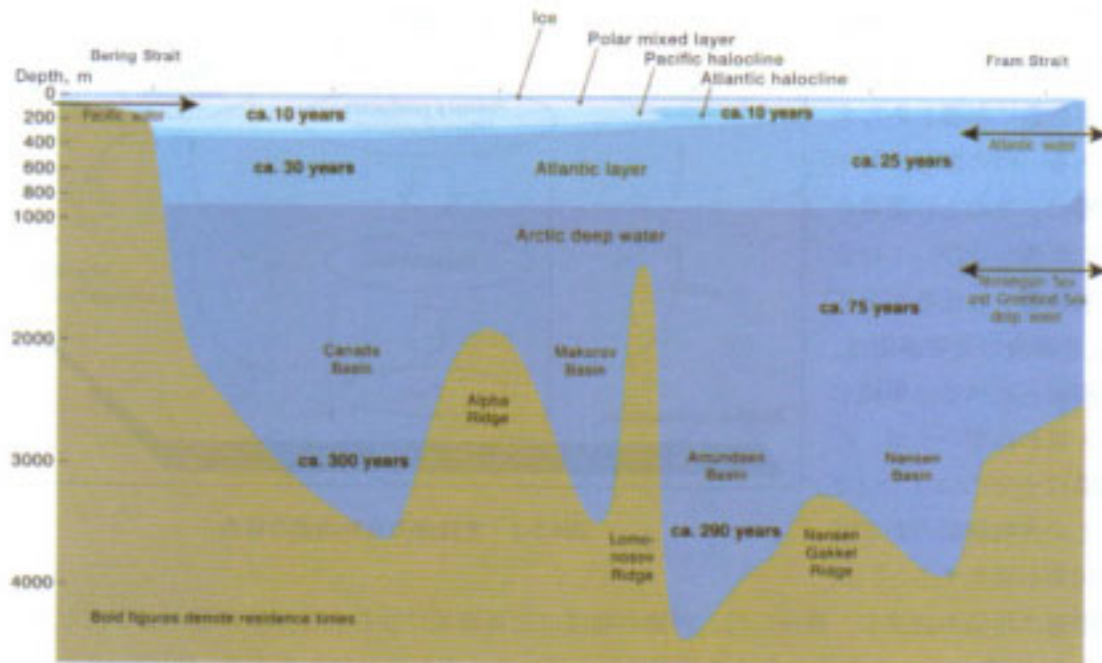

Source: AMAP: Arctic pollution issues: A state of the Arctic environment report. Arctic Monitoring and Assessment Programme (AMAP), 1997.

Figure 4.5-2 Vertical section of the Arctic Ocean and the different water masses with their approximate residence time

characterize the surface currents of the Arctic Ocean. The first is the Transpolar Drift, in which the surface waters of the Eurasian basin move across the basin toward the North Pole and then toward the Fram Strait; the second is the anticyclonic flow around the Beaufort Gyre in the Canadian Basin. In the deep waters of the Arctic Ocean, water masses exhibit complex movements. Mean surface current speeds are slow, at about 1–4cm/sec (300–1,200 km/year). Because the Arctic Ocean is about 4,000 km wide, the surface layer is to be completely replaced in three to 10 years. An estimation based on drifting speeds of sea ice gives an average residence time of 5 years.

The vertical structure of the Arctic Ocean and the average residence time of water masses is illustrated in Figure 4.5-2. Below the Polar mixed layer of low salinity near the surface, haloclines exist, of which average residence time is about 10 years. The Atlantic layer below the haloclines is believed to have an average residence time around 30 years. Deeper still, the Arctic deep water below the Atlantic layer has an average residence time over 100 years.

4.5.2 Indigenous Peoples and the Ecosystem in the Arctic Ocean

To understand how pollution is spread and how it affects the ecosystem, it is important to look at the structure of the food chain. As in all other oceans, the primary producers of the food chain in the Arctic Ocean consists of small algae such as the pelagic unicellular algae, or phytoplankton. Together these species account for 97% of all the marine lives in the Arctic Ocean. The productivity of phytoplankton is controlled by light and the nutrient, which is closely connected with the retreat of the ice edge in spring. Forming the base of the food chain, phytoplankton is consumed by the next link in the chain above them, zooplankton such as small crustaceans. Cod and other fish live at the third trophic level being fed by the zooplankton. The fish provide the main source of sustenance for seabirds and marine mammals that are at the top of the food hierarchy. The fish therefore play a vital intermediary role, delivering the energy produced by the plankton to the vertebrates living on the ice. Figure 4.5-3 shows an overview of the food chain, illustrating how far various impact factors affect

the elements of each ecosystem (for example, sea birds). These impact factors affect the abundance of flora and fauna in each element of the ecosystem. Anything that has an impact on one level of the food chain affects the one above it, until ultimately the entire ecosystem is affected. The food chain in the Arctic Ocean is simpler than that in other oceans, which indicates that the Arctic ecosystem is more vulnerable to

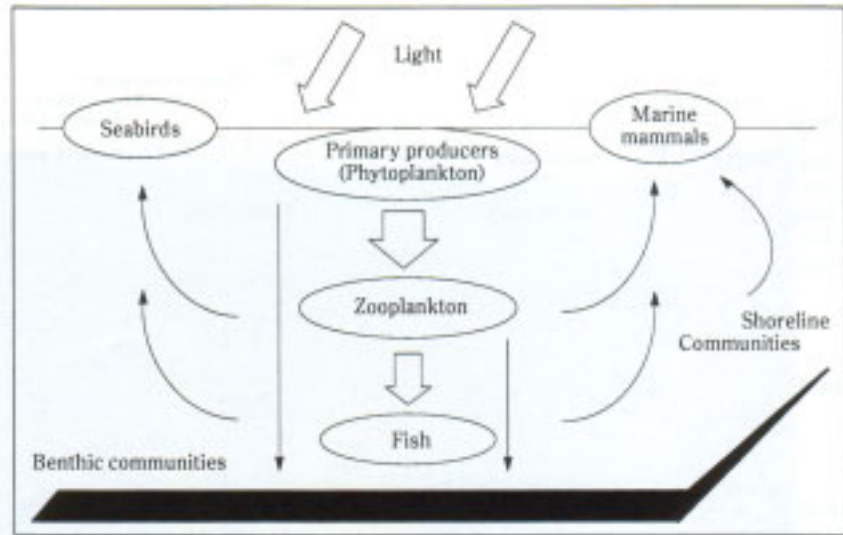

Figure 4.5-3 Simplified scheme of the Arctic marine food chain

external shocks than other ocean ecosystems. This complex web of bio-relationships is poorly understood at present. If pollution occurs at one level of the food chain, it quickly permeates the upper levels as well, until finally indigenous peoples in the Arctic are affected by the bioconcentration of pollutants.

The vastness of the NSR encompasses a richly diverse population of species at each level of the ecosystem. Because it cannot practically assess all of the flora and fauna in the Arctic, INSROP limited its study of environmental impact to issues of high priority. INSROP selected a number of indicator species by screening according to an environmental assessment index called Valued Ecosystem Components (VECs), in which issues are weighted their value in monitoring environmental impact and the ease with which data can be gathered, taking into consideration such factors as the conditions of navigation and distribution of habitats (Table 4.5-1). Although not all of the VECs are fully available, the VECs have been entered into the Geographical Information System (GIS) to compile a database called the Dynamic Environmental Atlas (DEA). One example of the information contained in the DEA is the distribution of polar bear, one of the species at the apex of the Arctic food chain. This distribution is mapped as in Figure 4.5-4. Undeniably these data suffer from a lack of quantitative rigor, but to INSROP they are priceless, as they represent the first such data ever provided by Russia on this topic—data that are indispensable to the environmental assessment in Section 4.5.4.

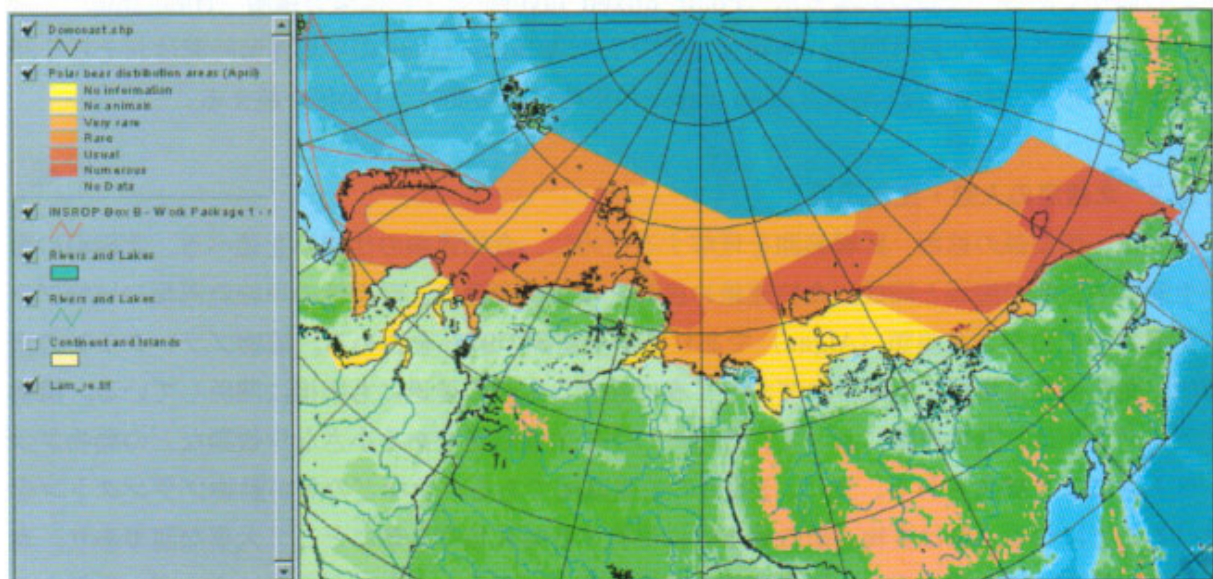

Figure 4.5-4 Distribution of the population of polar bears

Table 4.5-1 Selected Valued Ecosystem Components

Selected Valued Ecosystem Components — VEC_s			
Indigenous-local peoples: Human settlements; residence and subsistence areas of 16 northern indigenous minorities + 2 additional major ethnic groups.			
Waterland border zones: Shoreline attributes; sediment composition — topography; inundated riverine areas, also including polynyas.			
<p>Benthic Invertebrates, incl. distribution of:</p> <ul style="list-style-type: none"> ● Sampling and monitoring stations ● Sediment features ● Bio-coenosis ● Species name and numbers (corresponding to more than 2,000 different taxa) 	<p>Marine, Estuarine and Anadromous Fish, incl. distribution of:</p> <ul style="list-style-type: none"> ● Scorpion fishes (25 taxa) ● Salmonids (17 taxa) ● Gadoids (16 taxa) ● Whitefish (6 taxa), incl. recorded landings and catch statistics 1980–90 	<p>Birds, incl. distribution, abundance, migrations, feeding and breeding areas of:</p> <ul style="list-style-type: none"> ● Brunnich’s guillemot ● Black guillemot ● Common guillemot ● Ivory gull ● Ross gull ● Kittiwake ● Common eider ● King eider ● Steller’s eider ● Spectacled eider ● White-fronted goose ● Barnacle goose ● Brent goose, incl. dark bellied B. goose ● Bean goose ● Emperor goose ● Long-tailed duck ● Waders; feeding and resting areas 	<p>Marine mammals, incl. distribution, abundance, migrations, feeding and breeding areas of:</p> <ul style="list-style-type: none"> ● Polar bear ● Walrus ● Bearded seal ● Ringed seal ● White whale ● Grey whale ● Bowhead whale

4.5.3 Activity in the NSR and Environmental Factors

In this section we look at the impact factors that ships navigating the NSR bring to the Arctic environment.

(1) Continual impact

Most ships in service in the NSR have been built after the MARPOL 73/78 Convention came into force, and therefore meet its requirements. The few ships constructed before the MARPOL 73/78 are remodeled to satisfy this treaty and Russian environmental regulations. Continual pollution factors can therefore be said to consist of engine exhaust, oily water, sewage and garbage.

Air pollution caused by the exhaust from NSR vessels consists of emissions into the atmosphere of SO_x, NO_x and hydrocarbons from the consumption of fossil fuels. At this point, although no specific regulations on these pollutants exist, estimates of total ship emissions can be made. Ships that navigate the NSR are generally equipped with low- or medium-speed diesel engines, which are estimated to release a total of 1-1.5 t of SO_x and 2-2.5 t of NO_x per day.

The oily water is caused by bilge from the engine rooms of ships, fuel and lube separation residues, washing, coupling leaks, etc. Water pollution from daily activities such as cooking and showering is considered a minor threat to the NSR environment and is not objected to national regulations, but toilet and medical sewage must be processed and purified.

All ships navigating the NSR are equipped with sewage treatment units, oil filtering/separating systems, strainers, garbage-collectors and incinerators. The ship waste volume depends on the number of crew aboard as well as the type, size and age of the ship. Most garbage is incinerated on board, but incombustible wastes and sewage processing residues are delivered to reception facilities in ports.

Russian standards require that engine noise level is not to exceed 105dB. However, the in situ noise level during operations in ice-covered waters will depend on numerous factors and would be difficult to estimate

Table 4.5-2 Estimated ship waste volumes

Type of ship	No. of ships	Dw 10 ³ t	Size of crew	Ship waste volumes				
				Oily water			Sewage m ³ /day	Garbage kg/day
				Water m ³ /day	Oil kg/day	Oil discharge to sea kg/year		
Container carrier	3	5.7	35	1.5	30		3.4	30
		20	41	4.0	80	40	4.1	40
		20	41	4.0	80		4.1	40
Timber carrier	84	10	21	2.5	50		2.1	20
		8	38	2.0	40	490	3.8	35
		4	21	1.3	25		2.1	20
LASH	2	34	77	6.0	120	25	7.7	70
Dry cargo ship	27	20	41	4.0	80	480	4.1	40
Reefer	3	3	31	1.3	25	16	3.1	30
		17	46	3.6	70		4.6	45
Tanker	20	6	36	1.9	40	57	3.6	35
Multipurpose ship	46	5.0	31	1.5	30		3.1	30
		10	57	2.5	50	290	5.7	55
		20	57	4.0	80		5.7	55

4. Technological Aspects of NSR Navigation

on a regular basis.

(2) Accidental oil spills

Despite the difficulties of NSR navigation, no large-scale oil spills from tankers have ever occurred in the NSR, although minor spills have occurred during bunkering operations at sea and loading oil from temporary pipelines. The volume of such minor spills does not exceed 100-200 liters.

The factors that increase the danger of ship and spilling accidents are many, but the principal factors are hull structure and the state of maintenance, actual operations and human factors. Despite decades of progress in the engineering aspect of navigation, human factors remain the hardest to pin down and the likeliest to cause accidents. The most common cause of ship accidents causing oil spill is collision and grounding on shoals. According to IMO data gathered on a worldwide basis, the average annual frequency for accidents involving tankers of 6,000 register tonnes or more is 31% for collision with other ship or ice and 41% for groundings.

GESAMP (1993) and Engelhardt (1985) report that numerous small-scale oil spills and blow-outs of natural gas have occurred in the Arctic Ocean during loading of oil into tankers and development and production in offshore oil and gas fields. Even these statistics, however, are insufficient to calculate the precise probability of oil spills in the NSR. The estimates for the Baltic Sea indicate that the spill probability on the high seas is about 0.005%, and about 0.25% in high-risk areas (Maisson and Forsman, 1995). Table 4.5-3 shows an estimate of the spill quantity in the NSR on the assumption that an average of 1/48 of the quantity of oil carried on a voyage is spilled in each accident, taking into account the frequency of accidents of collisions and groundings. If these figures were applied to tankers plying the NSR, the spill quantity due to accidents would be 207t in the case of the Ventspils and 503t for the Samatlor.

Table 4.5-3 Estimated spill quantity in the NSR

Arctic Region	Transported quantity per year (1,000 tons)	No. of Journeys per year	Risk 1000 journeys	No. of spill-accidents per year	Spill quantity/year (tons)	Average spill quantity (tons)
Total of the NSR	392,401	50	0.4	0.02	3.3	163.5
West Region	166,893	23	0.25	0.006	0.9	151
East Region	225,508	27	0.25	0.007	1.2	174

The above estimate is strictly a reference value indicating the frequency of accidents and spill volumes likely to occur according to probability theory; it does not take account of extraordinary events that can and do take place. For example, if serious inherent cracks on a ship hull remain undetected prior to loading or unloading, they could rapidly extend over a considerable length of the side shell plating. Failure to notice such a crack can lead to the spilling of 500-1,000t of oil in a single hour. The massive 35,000t spill that occurred in the well-known case of the Exxon Valdez, and the even more catastrophic 85,000t spill in the Braer, were caused by such cracks. In other words, there is a yawning gap between the record of actual incidents and theoretical estimates. The GESAMP statistics cited above also show that oil spill quantity fluctuates wildly from year to year, reflecting a function of the number of accidents and the type of ships involved; the same can also be said of environmental impact. Each spill has its own nature, and the environmental impact cannot be addressed by a simple function of the spilled volume.

(3) Identifying relevant impact factors in the NSR

As all impact factors are assumed to be linked to either normal operations and/or accidental events, probability of impact in the NSR relates to one or more of the following three factors.

- * Operations of individual ships, including supporting icebreakers
- * Port/harbor facilities (cargo storage, cargo handling equipment, support of fuel and crew, and waste reception facilities)
- * Infrastructure for cargo and crew support

The first element listed above is considered entirely marine in nature, while the last component is considered land-based, The second element represents the intermediate link between land and sea. The main activities above can be broken down into sub-activities – the specific activities in situ, used to identify the corresponding impact factors, which can be grouped into the following five categories.

- * Emission to air
- * Physical disturbance
- * Discharge to sea, ice and/or land
- * Noise
- * Changes of development pattern

The above categories are used as a reference for classifying the impact factors for ships; for environmental factors related to port facilities and infrastructures, please refer to Thomassen et al. (WP-162). Operational and accidental ship factors are summarized in Table 4.5-4. Using these factors, it is possible to carry out an environmental impact assessment, as described in Section 4.5.4.

4.5.4 Environmental Impact Assessments

The term "environmental impact assessment" is often surrounded by much confusion, as a wide divergence of opinions exists as to its definition and objectives. This discrepancy is often the cause of many hours of debate between developers and environmentalists concerning the severity of an activity's environmental impact. The definition of terminologies in environmental impact assessment is inconsistent and evaluation procedures often lack transparency and reliability. Moreover, data on which a reliable conclusion can be based are frequently in short supply; doubts about evaluation procedures are often rooted in a lack of adequate data. Therefore, it is crucial the principles of environmental impact assessment applied and the actual methods used be clearly laid out. Environmental impact assessment in the NSR consists of the following three key elements. Elements (1) and (2) have already been discussed, in Sections 4.5.3 and 4.5.2 respectively. Element (3) will be an approach to evaluate the effects of the element (1) on the element (2), both qualitatively and quantitatively.

- 1) Selection of impact factors from the operation of ships in the NSR
- 2) Assessment through quantitative distribution of valued ecosystem components
- 3) Environmental impact assessment

(1) Biological impact

Impact factors incur direct biological effects through either chemical toxicity and/or mechanical stress, when the habitat of organisms is disturbed either chemically or physically so that important functions of the creatures, such as photosynthesis, enzyme, nervous system, thermal regulation, food consumption, reproduction and other behaviors are inhibited. Organisms that are not affected directly may be indirectly affected by changes in co-existence dynamics such as the interactions between prey and predator.

4. Technological Aspects of NSR Navigation

Table 4.5-4 Correlation between specific NSR activities and impact factors in operational and accidental accidents

Main type of activity Key parameters	Specific (<i>in situ</i>) activities	Main type of impact factors	
		Operational	Accidental
Ship			
Identification of ship: <ul style="list-style-type: none"> Type of ship Year of building Class, class notation (incl. hull type: single, double, ice-strengthened) Nationality of ship/flag state 			
Size of ship: <ul style="list-style-type: none"> Dead-weight (dw) Gross tonnage Wetted surface or outer dimensions Length (overall), width, depth 	Ship in operation	Physical disturbance Noise	Physical disturbance Noise
Engine specifications: <ul style="list-style-type: none"> Type of engine(s) Fuel consumption 	Ship operation Energy production <ul style="list-style-type: none"> Main engines Auxiliary engines Boilers, incinerators, refrigerating systems 	Emission to air: <ul style="list-style-type: none"> Exhaust gases Noise	Releases of: <ul style="list-style-type: none"> Fuel Radioactive material
Fuel specifications: <ul style="list-style-type: none"> Fuel type Volume of fuel 	Ship operation Energy production	Emission to air: <ul style="list-style-type: none"> Exhaust gases 	Releases of: <ul style="list-style-type: none"> Fuel Radioactive material
Cargo: <ul style="list-style-type: none"> Type of cargo (UN number) Volume of cargo 	Cargo operation: <ul style="list-style-type: none"> Liquid cargo Dry cargo 	Emission to air: <ul style="list-style-type: none"> Evaporation of cargo Discharges to sea: <ul style="list-style-type: none"> Loss of cargo 	Release of <ul style="list-style-type: none"> Cargo
General standards and procedures: <ul style="list-style-type: none"> Handling of ballast water: shifting routines, tanks segregation, and volume Handling of waste and spill Anti-fouling: type of paint 	Handling of ballast water: <ul style="list-style-type: none"> Shifting Tank washing Handling of waste and spill: <ul style="list-style-type: none"> Cargo residues Fuel residues and sludge Bilge Waste Anti-fouling treatment of hull/wetted surface	Emission to air: <ul style="list-style-type: none"> Combustion of waste Discharges to sea: <ul style="list-style-type: none"> Ballast water Cargo residues Fuel residues and sludge Bilge water Garbage and litter Sewage Release of anti-fouling paint Alien species	Releases of: <ul style="list-style-type: none"> Ballast water Cargo residues Fuel residues and sludge Bilge water Garbage and litter Sewage Alien species
Ship support: <ul style="list-style-type: none"> Helicopter Aeroplane 	Support routines	Noise	Physical disturbance Releases of: <ul style="list-style-type: none"> Cargo Fuel

The worst impact on the biosphere results from increases in mortality, decreases in survival rate of growing organisms and growth rate, and increased incidence of sudden fluctuations in these indexes. Ordinarily organisms relatively high in the food chain have generally developed adaptive responses to neutralize and counteract the impact of pollution. Once pollution has taken place, reactions at the cellular level are initiated to deactivate and excrete particular constituents of pollutants. Moreover, when mortality at the population level in single species increases, the mortality may be compensated by increased fecundity.

When an organism is invaded by the contaminant and the adaptive responses are activated, the organism is

considered to be in a state of environmental stress. If the quantity of contaminants exceeds the organism's ability to deactivate and excrete them, the contaminants or contaminant residues accumulate in the organism. The international academic community has developed efficient methods for investigating adverse effects at most organizational levels. In environmental impact studies, however, from a strictly biological point of view it is the population and not the individual that is important and it is argued that unless an effect has consequences at the population level it is insignificant, as McIntyre et al have asserted (WP-162). INSROP incorporates this point of view in its environmental impact assessment and has adopted it in its environmental impact assessment of offshore oil-field development in Norway.

To produce biological effects and environmental impact, impact factors such as contaminants and noise must have sufficient time to interact with ecosystem components. Impact factors and ecosystems are both temporally and spatially changing, in a state of contemporaneous disequilibrium. Environmental impact potential will therefore correspond to the state of the two parts at the moment of interaction. The impact is considered to continue as long as both parts coexist in a given area and as long as deviations are observed in environmental parameters between the influenced and the uninfluenced areas. To estimate the ultimate measure of damage, the following combined parameters should be taken into account in combination:

- * Extent of damage
- * Duration of damage

The immediate damage corresponds to the initial response when the ecosystem is exposed to the source of pollution. The duration of damage, also called the recovery period, is the period from maximum damage until the populations and community structures have reverted to a state similar to the uninfluenced system components in species composition and age distribution.

All kinds of biological resources have a potential role to play in the recovery of the environment, which can be understood in the functions of abiotic factors (type and fate of contaminants, exposure period and dosage, etc.) and biotic factors both intrinsic and extrinsic (physiological adaptive responses, tolerance and resistance, fecundity, reproduction strategy, food access, etc.). The intrinsic factors include specifics of species, population and community, as well as individual tolerance-sensitivity to the given contaminant based on these factors. In extreme situations of rapid population decrease, the population may lose its ability to restore itself or recover, leading to permanent decline in the population. When the physical and chemical properties or size of the habitat is altered or disturbed, the region may become unsuitable for the organisms. Vulnerability to hazardous substances and environmental stress indicate potential damage to a given ecosystem component, which could have been caused by an impact factor. In INSROP environmental impact assessments, the relative vulnerability of ecosystem components and main species was indicated on a scale by a set of indexes. As each ecosystem component refers to a particular type of environmental impact, each index is specific to a given impact factor.

(2) Evaluation of vulnerability and potential impact level

For each selected component in the ecosystem, impact hypotheses have been developed to suggest situations under which impact may occur. In Phase I of INSROP, for the selected Valued Ecosystem Components (VECs), a total of 59 impact hypotheses were identified. In Table 4.5-4, these hypotheses are correlated with a number of specific activities and the impact factors in the NSR operation. For each hypothesis, a schematic flowchart was drawn to illustrate the possible impact of the specific activities in relevant development on each VEC. Each hypothesis was classified as follows:

4. Technological Aspects of NSR Navigation

Table 4.5-5 Examples of impact hypotheses

Valued Ecosystem Components	VEC No	IH No	Impact hypotheses (IH)	Category	
				in general	this scenario
VEC Benthic invertebrates	A1	A1-1	• Accidental discharges of pollutants will affect benthic invertebrates.	B	_*
		A1-2	• Pollution from ship traffic will affect survival of pelagic larvae of benthic invertebrates at certain times of the year.	C	D
		A1-3	• Chronic pollution will cause accumulation, of pollutants in benthic invertebrates.	B	D
		A1-4	• Hardbottom epifaunal organisms can access new substrates by colonising the surface of dumped waste.	D	_**
VEC Marine, estuaries and anadromous fish	A2	A2-1	• Accidental pollution will cause reductions in certain fish stocks if it affects area with high concentrations of fish, such as migration, nursing or feeding areas.	C	_*
		A2-2	• Due to low diversity at each trophic level, effects on one single species will cause major impacts in the rest of the food chain.	B	D
		A2-3	• Discharges of oil or other pollutants in fresh water or along the coastal NSR area will cause increased mortality and reduced production in anadromous fish populations.	C	D
		A2-4	• Physical disturbance to fishes by the ship moving in ice will cause increased mortality in cryopelagic fishes.	C	C
VEC Plant and animal life in polynyas and marginal ice zones	A3	A3-1	• Any effect of NSR traffic will be manifested to a greater extent in polynyas than in other areas.	C	C
		A3-2	• Noise from ship traffic will scare fish, mammals and seabirds away from important feeding, resting and breeding areas in and near polynyas.	C	C
		A3-3	• Oil spills in polynyas will reduce primary production, and thus affect the whole feeding network.	C	_*
		A3-4	• Even minor oil spills in polynyas, from regular NSR traffic, will cause suffering and death to vertebrates.	B	_*

A: The impact hypothesis is deemed to be invalid.

B: The hypothesis is valid and proven, and no further research is required.

C: The impact hypothesis is believed to be valid but further study is required to examine and monitor the appropriateness of the hypothesis.

D: The hypothesis is valid, but impact poses little threat to the ecosystem so further study is unnecessary.

Of 59 impact hypotheses evaluated, four were categorized as A and 14 as B—these were found not worth testing; 14 were categorized as D and found valid and already verified. The remaining 27 hypotheses were classified as C, indicating that they were assumed valid but further investigations were recommended for validation. As an example, Table 4.5-5 shows the impact hypotheses examined with respect to a few components of the VECs, benthic vertebrates, marine, estuarine and anadromous fish in the case (specific activity) of summer operation with container vessels in the NSR.

Various methods have been developed for qualitative assessment of vulnerability and semi-quantitative evaluation of environmental impact. The application of these methods in the environmental assessment and planning system depends on the accuracy and resolution of the database. Generally, semi-quantitative methods are applied where high-resolution data are available; otherwise qualitative methods are chosen. Figure 4.5-5 shows a flowchart for an environmental assessment and planning system and the principle procedures. To examine impact hypotheses and estimate the impact significance, a standard method called the ESSA method is used. This method introduces scaled parameters for indications of the potential impact level, which are spatial scale, temporal scale and perturbation magnitude. Each of the parameters consists of three levels, given scores from 1 to 3, as shown in Table 4.5-6. The multiplication of the three parameters yields 27 different values and they are grouped into three classes, relating to the corresponding level of the potential impact levels; low, medium or high potential impact. For example, as shown in Figure 4.5-6, INSROP GIS was applied to assess the potential impact level of noise and disturbance from navigation (the impact factor) on ivory gulls (the VEC). Most INSROP GIS data are unsuitable for quantitative evaluations as shown in Table 4.5-6, and in many cases, the distributions are given only at relative level.

Table 4.5-6 Key parameters for evaluating impact significance

Score	Spatial scale (S)	Time-scale (T)	Perturbation magnitude (P)
1	Local effect	Short term	Small perturbation
2	Regional effect	Medium term	Moderate perturbation
3	National/international level	Long term	Large perturbation

4.5.5 Environmental regulations

As our understanding improves of the extent of environmental pollution and its future impact, people of all nations and regions are coming to realize how important it is to reduce and eliminate wherever possible the pollution that attends human activity. Because the ocean covers 70% of the earth's surface, marine pollution is a particularly critical issue of global significance. The sources of marine pollution are found on land and in the air as well as at sea; pollution from ships accounts for a relatively low 12% of the total (Kuribayashi, 1999). Nonetheless, the Arctic Ocean in which the NSR lies is unusually vulnerable to pollution, and its exceptionally

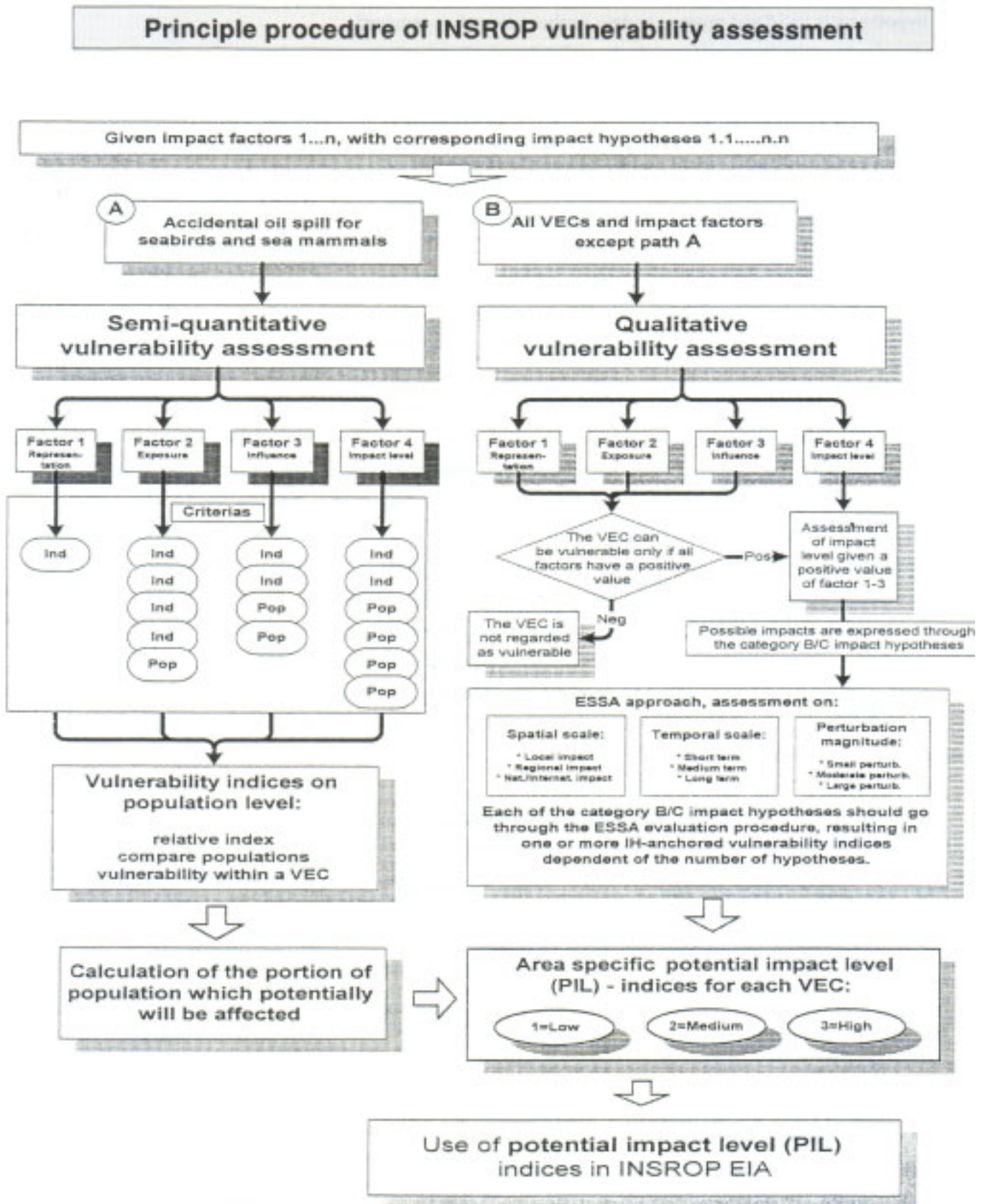

Figure 4.5-5 Principal procedures of INSROP vulnerability assessment

The following abbreviations are used: Valued Ecosystem Component — VEC; Dynamic Environmental Atlas — DEA; Impact Factor — IF.

- a) In the beginning was the natural environment ... In a selected area of the NSR, some VECs are common at certain periods of the year. The relevant type of data (in this example on Ivory gull) is stored in the DEA data-base and standard routines are developed for compilation of key information on maps and tables.
- b) Ships of the NSR fleet navigate the selected waters regularly. The spatial navigation pattern is applied to the environment in terms of historical sailing routes. The navigation however represents a certain level of physical disturbance and noise, two types of IFs to the VEC. The spatial range of the IF, in terms of the area that may be influenced by noise, are calculated and applied to the routes by tailored buffer-routines.
- c) By joining the area affected and the Ivory gull distribution, the intersections between the IF and VEC abundance can be identified and the fraction of the populations affected can be calculated.
- d) On the basis of the VEC distribution (3-16a), the range of the IF (3-16b) and the vulnerability to the IF, algorithms are developed to aggregate this information on a grid level, i.e. counting the fractions affected within each cell. The aggregated results are the non-dimensional PIL indices (none, low, medium, high), indicating the potential impact level.

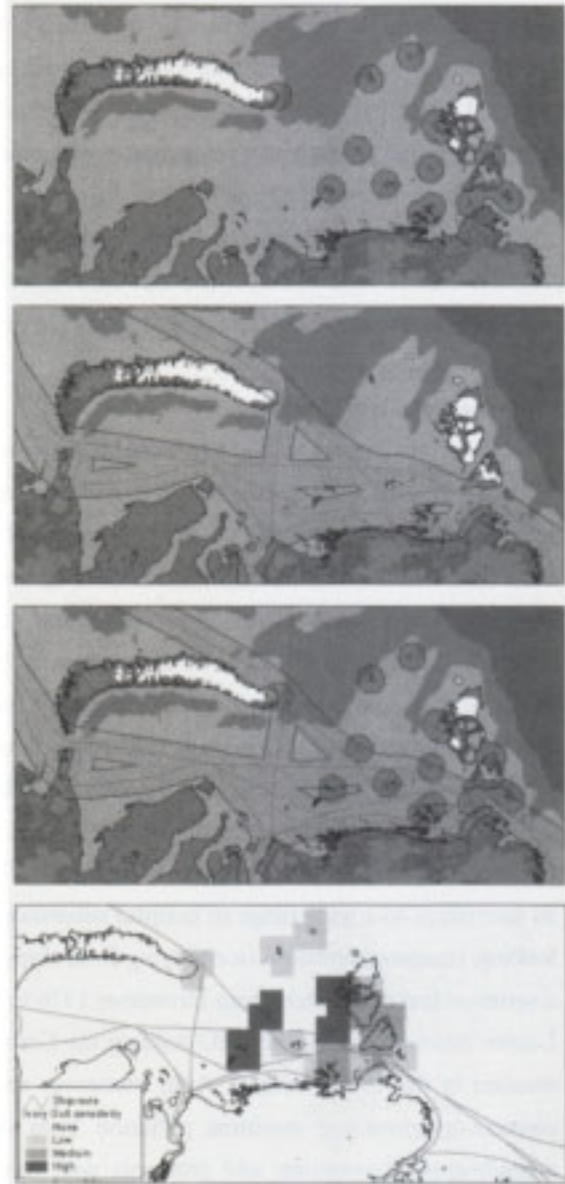

Figure 4.5-6 Outline of the step-based approach to impact assessment

harsh environment aggravates the danger of accidents. Moreover, if the NSR, which has for so long been closed to passage by foreign vessels, should experience a sudden and dramatic rise in traffic, the pollution of the NSR by ships would become a grave threat to the NSR environment. It has also been pointed out that the open water channels created by navigation would have a biological impact, and the noise emitted in both air and water by navigating ships is known to affect the breeding seasons of many organisms. At the very least, control must be adopted to minimize the impact of these disturbances on the fragile Arctic ecosystem.

Marine pollution originating in the operation of ships is unique for two reasons. First, the area affected by this pollution is extremely wide. Second, its impact and the measures needed to tackle it are distinctly international in character. For these reasons, provisions of international law, such as conventions of the United

4. Technological Aspects of NSR Navigation

Nations and other international agencies and regional agreements among affected countries, have long been in place to govern these issues. These treaties and conventions aim to prevent or reduce the environmental damage from ship waste and spills of hazardous substances in accidents. In addition, many countries have enacted their own legislation on the subject, based on their own priority principle or simply after the international law. If the NSR is defined as an international shipping route, a vast influx of foreign ships will begin navigating seas recognized as an exclusive economic zone or territorial waters of Russia, or even the waters which Russia claims as internal. Adequate consideration of pollution caused by vessels in the NSR is indispensable to conform to both international and Russian laws.

In this section, a brief summary of international law is first presented, focusing particularly on vessel-source pollutions. This is followed by a description of international efforts to preserve the environment of the Arctic Ocean. Second, the domestic laws of Russia are surveyed for vessel-source pollutions.

(1) International law

One of the longest-recognized vessel-source pollution is oily water pollution caused by discharged bilge. This ship-based source of pollution is one of the more internationally regulated areas of marine pollution. The International Convention for the Prevention of Pollution of the Sea by Oil (OILPOL), proposed in 1954 and enforced in 1958, was the first international agreement on marine pollution. Also in 1958, the International Maritime Organization (IMO) was established as a technical agency of the United Nations. This body officially adopted the OILPOL in the same year. The principal functions of the IMO are the promotion of maritime safety and the protection of the marine environment. Amendments to OILPOL were made in 1962 and 1969 and enforced in 1967 and 1978 respectively. OILPOL was the first convention to attempt to control marine pollution and served as a basis for establishment of the succeeding conventions. The amended OILPOL was later found to be inadequate to deal with marine pollution, however, and so the International Conference on Marine Pollution was held in 1973. This conference adopted the MARPOL73, which extended its provisions to a wide range of harmful substances and discharge, including any effluent, disposal, spilling, leaking, pumping, emission or emptying from ships. Enforcement of MARPOL73 was slow at first. However, a series of tanker disasters from December 1976 to January 1977, including the Olympic Game and Universe Leader incidents, led to the IMO holding the Conference on Tanker Safety and Pollution Prevention, which resulted in the 1978 Protocol. After numerous amendments, MARPOL73/78 is now the world's foremost convention governing maritime pollution from ship activity. The IMO subsequently adopted numerous amendments, conventions and protocols with more specific objectives for environmental protection. The Convention for the Prevention of Marine Pollution by Dumping of Wastes and Other Matter (London Dumping Convention of 1972) dealt with dumping on a global basis, aiming to protect the marine environment principally through the restriction of disposal at sea of waste materials. More recently, this organization adopted the International Convention on Oil Pollution Preparedness (OPRC) governing international cooperation against oil pollution.

Other provisions of international law also deal directly or indirectly with environmental preservation issues regarding ships and the use of the sea. The recently enacted UNCLOS, often called the "constitution of the sea," is a comprehensive body of law governing a wide range of maritime issues. Of its 17 chapters, one chapter deals specifically with matters of environmental preservation. However, treaties on ship safety can be considered part of the international law on preservation of the maritime environment, as they provide for measures to prevent spills of harmful substances in the event of accidents. The best-known treaty on ship safety is SOLAS. SOLAS is a treaty with a long history. First concluded in 1914, it has been updated twice

since the formation of the IMO, in 1960 and 1974, in the form of new treaties. In 1978, and later in 1988, the 1974 treaty was supplemented with protocols.

* MARPOL 1973/1978

The official name of MARPOL is "the International Convention for the Prevention of Pollution from Ships, 1973, as modified by the Protocol of 1978 relating thereto", which is widely known as MARPOL 73/78. Included in the Convention are six appendices for the prevention of pollution, labeled I to VI, dealing respectively with oil; noxious liquid substances in bulk; harmful substances carried by sea in packaged forms; sewage; garbage; and halon, freon, sulphur, nitrogen oxides and volatiles. Two of these six appendices, IV and VI, have not yet entered into force. In addition to regulations for the prevention of operational pollution, regulations were added to reduce pollution in the event of accidents. In the revision of 1992, structural requirements for double hulls in tankers were adopted. By a revision in 1991, the Shipboard Oil Pollution Emergency Plan (SOPEP) was adopted as compulsory.

* OPRC

Officially named the International Convention on Oil Pollution Preparedness, Response and Cooperation, 1990, this convention was adopted with the objective of minimizing the damage from large-scale pollution accidents involving ships, offshore structures, marine facilities and petroleum-related facilities. OPRC provides for wide-ranging international cooperation, including the exchange of information on each country's preparedness for pollution accidents; preparation of contingency plans for response to oil-pollution incidents; exchange of reports on major incidents that may be harmful to the marine environment, the coastal environments of various countries and their related economic ambience; mutual support in research and development of prevention methods and promotion of international cooperation.

* UNCLOS

This umbrella convention, officially known as the United Nations Convention on the Law of the Sea of 1982, is a comprehensive convention establishing laws to deal with all areas of marine pollution, concerning territorial waters, contiguous zone, the continental shelf, the high seas and the deep sea floor. The convention was deliberated at the third UN Conference on the Law of the Sea, which was held from 1973 to 1982, and adopted in 1982. UNCLOS had not entered into force for long because a number of developed nations expressed dissatisfaction with the provisions of Part XI of the convention, referring to the development of the deep-sea floor. To break the impasse, the UN Secretary-General held a series of informal talks, at the end of which an agreement on revised rules was adopted in 1994 and became effective in the same year. Part XII of the convention establishes measures to protect and preserve the marine environment, and to prevent, reduce and regulate pollution of the oceans. UNCLOS recognizes flag state jurisdiction but supplements this concept by port state jurisdiction that enables states to prosecute vessels using their ports and terminals for offences committed anywhere at sea.

* SOLAS

SOLAS, officially called the International Convention for the Safety of Life at Sea, establishes minimum standards for the construction, equipment and operation of ships to ensure the safety of persons at sea. Since the first SOLAS in 1914, technologies of shipbuilding and navigation have progressed markedly and large-scale accidents occurred successively, and the circumstances spurred the adoption of new treaties, protocols and amendments. A protocol of 1974 deals mainly with improvements to the safety of tankers and strengthening of the provisions for ship inspection, with a view to preventing marine pollution.

4. Technological Aspects of NSR Navigation

(2) International laws and international cooperations on environmental preservation in the Arctic Ocean

As described above, international laws for the prevention and reduction of pollution of the environment by ships are well established. However, few norms and regulations explicitly address the special features of the Arctic Ocean. In Section 8, "Ice-covered Seas," of Part XII, "Preservation and Protection of the Marine Environment," of UNCLOS, Article 234 gives coastal states the right to adopt and enforce laws and regulations for the prevention, reduction and control of marine pollution from ships in ice-covered areas within the limits of the exclusive economic zone. However, the Convention does not indicate any special regulations reducing pollution from ships. For further comments on the Article, please see Section 4.3. In Appendices I and V of MARPOL, a revision adopted in 1990 and made effective in 1992 added the Antarctic region to the special areas in which provisions were strengthened regarding oil spillage and waste from ships. MARPOL does not contain any special requirements for the prevention of pollution in Arctic waters, although the Arctic countries have agreed to implement MARPOL's special area requirements for ships sailing in Arctic waters.

Clearly, the Arctic waters are behind the other waters in international legislation for prevention of pollution. Yet a number of activities are currently ongoing with the purpose of answering this concern. One organization at the heart of these efforts is the Arctic Council, a conference of the regional representatives of the Arctic countries that includes Canada, Denmark, Finland, Iceland, Norway, Russia, Sweden and the United States as well as representatives of the indigenous groups of the Arctic, which aims at improving Arctic cooperation on sustainable development and environmental protection and also at raising international awareness on Arctic matters. The Council, adopted a plan called the Arctic Environment Protection Strategy (AEPS). The Council activities have the five continuing components, one of which is the Protection of the Arctic Marine Environment (PAME). Through the PAME initiative, the Arctic Council aims to develop preparedness measures against marine pollution of any kind, in particular through existing international organizations and conventions such as MARPOL. Included in the PAME agenda are efforts within the IMO to include the Arctic Ocean as a special area under MARPOL and to recognize the region as a "particularly sensitive area."

At the same time, as discussed in Section 4.1 above, efforts are under way to establish an International Code of Safety for Ships in Polar Waters (Polar Code), a comprehensive set of regulations governing navigation in polar seas. In addition to requirements for the construction and equipment of ships for polar-water navigation, this draft code incorporates regulations for the protection of the environment. With respect to the discharge of pollutants from ships in the course of routine navigation, this code aims to apply the strictest provisions, either of MARPOL regarding special areas or of national regulations of coastal countries.

(3) Russian domestic law

Russian conservation and environmental legislation is a vast subject. Almost all general environmental legislation is applicable as appropriate to the Arctic. Recognition of environmental preservation in Russian domestic law can be seen in the country's fundamental body of law: the federal constitution. Article 9 of the federal constitution, which was passed into law in 1993, contains the preservation and use of the land and natural resources and the provisions of the best conditions for the lives of the peoples. Article 36, which governs property rights over land and natural resources, states that such rights may not cause harm to the environment. Article 42 asserts that enjoyment of a comfortable environment and access to information about the environment are rights of the peoples, but that such rights carry responsibility and liability for accidents,

indemnification and reparation.

Russian legislation pertaining to ecological safety of shipping, which includes the Arctic, is based on the Environmental Protection Law. This law was passed in 1991, around the time of the collapse of the Soviet Union, and was partially amended in 1992 and 1993. Each article of this law has since been supplemented with a succession of detailed legislation and administrative documents, whose contents are reflected in the Revised Environment Protection Law of 1996. Running to 13 chapters and 79 articles, the Revised Environment Protection Law contains the following basic principles in Chapter 1, Article 3, entitled "Basic Principles of Environmental Protection":

Local authorities, other state bodies, institutions, enterprises, plants and also citizens of Russian Federation, foreign juridical persons and citizens, persons without citizenship during economic, management and other activities which have negative influence on environment must be guided by the following basic principles;

- * Priority of person life and health protection, ensuring favorable ecological conditions for life, work and rest of population,
- * Scientifically grounded combination of the ecological and economical interests of society, ensuring real guarantees human rights on healthy and favorable environment for life,
- * Rational use of natural resources, taking into account laws of nature, potential effects on the environment, necessity of reproduction of natural resources, banning irreversible consequences for environment and person health,
- * Observance natural legislation requirements, inevitability of coming responsibility for its violation,
- * Publicity in work and close connection with public organizations peoples during solving of nature protection problems,
- * International cooperation in environment protection.

This law defines the main principles of the environment protection as well as the relevant authority bodies, their aims, tasks and obligations, and the economic instruments for environment protection and regulations for establishing ecological funds. The detailed regulations are contained in the domestic laws pertaining to each item therein. In one of its final provisions, the law refers to international laws and regulations which should be upheld and have priority over the provisions of the national regulations.

The Continental Shelf of Russia Law and the Code of Water define the sovereign rights and jurisdiction of Russia in the development of living and other resources in the Russian waters and on the continental shelf and also liabilities for contamination and encroachment of the environment during human-related activities, both enacted in 1995. The two laws are similar in content, but the latter is more specific regarding responsibilities, compensation, etc. The Code sets the framework for compensation for the utilization of resources. Based on these two laws, two administrative bodies, the State Committee of Environmental Protection and the NSR Administration, ensure environmental safety, inspecting and monitoring pollution caused by ships navigating the NSR. The State Committee of Environmental Protection is responsible for environmental protection policy at the federal level, designating environmentally protected areas and preparing the Red Book of Russia. The inspectors of these two organizations are authorized to inspect foreign and Russian vessels and other sea crafts for the environmental protection, and are entitled to detain ships until compensation has been paid for the damage in case of non-compliance.

To control discharge of pollutants by ships in the NSR, two sets of regulations are in force: the Regulations for Preventing the Pollution of Offshore Waters and the Sanitary Regulations and Norms for Preventing the Pollution of Offshore Waters in Water Supply Areas. According to these laws, the discharge of

4. Technological Aspects of NSR Navigation

oily water must satisfy the requirements for special areas under MARPOL, and processed sewage discharged during a voyage must have a coliform-group index no higher than 1,000 per liter of water. Garbage disposal at sea and storage of pollutants and waste materials on the ice are not permitted.

During the transition from the Soviet system to the present Russian system, Russia was left with various environmental problems and with deficient environmental norms, regulations and control procedures. Particularly under the economic conditions Russia has faced throughout the 1990s, no effective remedies have been developed with respect to the deficient systems and regulations for environmental issues, including ship-caused pollution in the NSR. For the moment, Russia seems to be somewhat behind in the legislation on environment compared with the laws of other countries (WP-128). However, in 1996, the same year as the promulgation of the Revised Environment Protection Law, a reorganization of Russian government agencies was carried out according to the Edict 1177 (“on the Composition of Executive Bodies”). This reform greatly improved the government mechanisms related to the enactment and oversight of basic environmental protection legislation. Presently, however, management of environmental protection at the regional level is still fragmented among the federal government and the various regional authorities. Similarly, the lines of responsibility and jurisdiction between the federal and regional governments are not always clear.

4.5.6 Conclusion

The main results of INSROP are the identification of VECs and the compilation and read-in of their approximate distributions into INSROP GIS, as well as the sharing of information with Russia regarding evaluation procedures of environmental assessment and related issues. Most cases in which impact hypotheses were applied were found to fall into category C, indicating that stationary and regular monitoring is vital to the selected VECs for their validation, when the NSR gets in active operation. At current NSR shipping levels, the impact from pollutants carried into the Arctic Ocean through rivers, currents and air mass from the northern European landmass is far more serious than that of NSR shipping. It is practically difficult to judge the real origin of pollution at the Arctic Ocean by the contaminants or disturbances, whether being provided by the NSR operation, or being brought by various activities on the European landmass.

4.6 Geographic Information System

4.6.1 Introduction

A Geographic Information System is a visual database system composed of digitized map information on a computer. In current car-navigation systems, driving routes are displayed on an on-screen map; the route and direction to a destination is selected from the database and delivered to a driver by the speaker. The system represents a form of GIS, since the system uses database to display geographical data. GIS for professional uses, however, are much more sophisticated and offer greater flexibility, utilizing common software on personal computers or workstations. Development of the NSR GIS was one of the primary subjects of INSROP, where considerable efforts to compile the Russian data on the NSR and improve workability of the system have borne fruit. The system is called INSROP GIS, and its objectives are as follows.

- [1] To construct a highly accessible database of geographical information of the Arctic region that can provide a foundation for long-term planning and rational decision-making for development of the region and for selection of the routes in the NSR
- [2] To enable rational decision-making based on a sound evaluation of all relevant issues of a case by making use of visible map and photo information in the GIS
- [3] To render geographical data on the NSR and Arctic Ocean visible and easy to search and analyze, presenting

INSROP data to the user in a systematic fashion

The following section presents an outline of INSROP GIS and a simple example of its application.

4.6.2 System Features and Composition

INSROP GIS offers the following features.

- [1] Data and analytical results are linked to geographical data in an easily accessible visual format.
- [2] A wealth of high-quality data on the Arctic Ocean, particularly the Russian Arctic, is stored from the joint research and development by Japan, Norway and Russia.
- [3] Environmental data at arbitrary points in the NSR can be easily retrieved and analyzed.
- [4] The data obtained using this system is expected to be applicable in simulations of the issues such as environmental impact assessment, planning of routes and design of various structures.
- [5] The system can easily be operated on an ordinary personal computer.
- [6] ArcView, a widely used, commercially available, general-purpose GIS software application, provides flexible linkage with the other software.

The overall structure of the system appears in Figure 4.6-1. The software and data for INSROP GIS is supplied by CD-ROM. Because this system is based on a customized version of ArcView, ArcView 3.0 must be installed in the PC. A PC, running Microsoft Windows with sufficient hard-disk space and memory, is required for the operation.

INSROP GIS consists of three parts. First, it contains a series of databases, covering geographical data, the natural environment, shipping routes and ecosystems. Second, a suite of application software enables this data to be retrieved and analyzed, allows the user to create and define new themes, and performs basic services such as filing and printing. Finally, an interface called a view-table chart is provided to display data in a graphical format.

Today a wide variety of GIS software components are available on the consumer market. As mentioned above, INSROP GIS is developed as an ArcView-application for use on PCs running Microsoft Windows, which was in turn developed by Environmental Systems Research Institute, Inc. (ESRI) of the United States and provides the necessary tools required to develop a comprehensive GIS application. ArcView renders geographical data in spatial form and provides retrieving, description and analytical functions. Also included is the object-oriented programming language, called AVENUE, from which ArcView was developed. AVENUE is provided to enable customization of ArcView or to program special analysis tasks not available from the default ArcView interface.

Since INSROP GIS is essentially a customized application on ArcView 3.0, it includes all of the functions of ArcView plus a wealth of comprehensive INSROP geographical data and analytical tools. In addition, the INSROP GIS component includes hard-copy layout templates for presentations, as well as INSROP hypertext documentation and analysis software.

Program data include map data, source data, and definition information used in retrieving, analysis and display functions, as well as scripts to link and organize these data and information. To make analysis of data on the NSR and the related issues as easy as possible, a script is included to enable customization of ArcView's menu- and help- functions.

4.6.3 Contents of the Database

ArcView contains a vast corpus of data on the natural environment in northern Russia and the Arctic Ocean, including the NSR, as well as shipping routes, distributions of ecosystems and data of infrastructure. To display

4. Technological Aspects of NSR Navigation

this information in an intuitive and easily comprehensible format, map data are provided as well. All of these

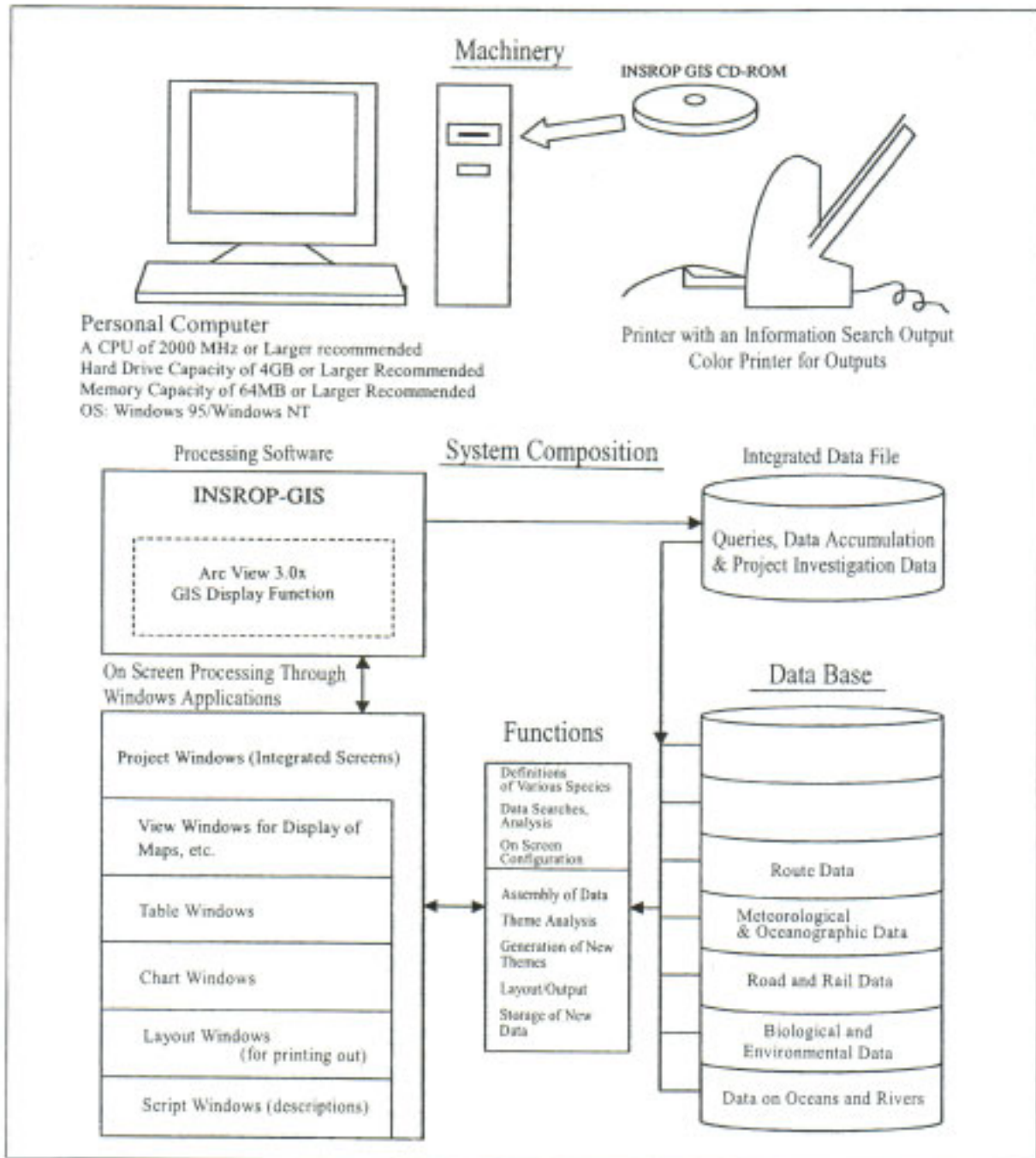

data were painstakingly accumulated through various projects of INSROP. Table 4.6-1 is a list of the data currently registered in INSROP GIS. An example of data display is shown in Figure 4.6-2, for average ice thickness in January around the NSR.

The topics in the database and their data sets are as follows.

[1] Map data

This data serves as the basis for display of various data. A broad map is prepared, sweeping from northern Europe through Siberia to the Far East.

[2] Ice data

These data, provided mainly by AARI, were compiled separately in several forms, and so consist of the following three types of data source:

1. Point data on ice conditions throughout a wide area of the Arctic Ocean: Satellite data from the last 20 years are divided into 25-square-kilometer segments.
2. Data at 24 observation points adjacent to the NSR
3. Data compiled for use in the NSR operation simulation described in Section 4.4

The content of the data can be categorized as follows.

a. Ice concentration

For each type of ice (first-year ice, multi-year ice, etc.), statistics of average, maximum and minimum values, etc. are stored as percentile or decile values.

b. Ice thickness

Statistics of average, maximum and minimum values, etc. are registered

c. Frequency of ice ridges

The number of ice ridges per 1 km of distance is stored (in data source type 3 only).

d. Size of pack ice

The sizes of pack ice are registered (in data source type 3 only).

[3] Meteorological data

The following meteorological data is in storage.

a. Air pressure data

Observation data of the US National Center of Atmospheric Research from 1964 to 1989 and of the Hydrometeorological Center of Russia from 1989 to 1994 are registered. A total of 384 data points were settled for a wide area covering 40°-210° E and 60°-85° N.

b. Air temperature data

These data are based on AARI data from an area 40°-210° E and 60°-85° N.

Table 4.6-1 Data stored in INSROP GIS

Category	Item	Data/source	Observation period	Contents
Ice and snow	Ice concentration and thickness	AARI Ice chart	1972 - 91	Monthly statistics for all years and monthly statistics for the years 1983 and 1990 (divided into a grid with squares 25 km × 25 km)
		INSROP Phase 1	1953 - 90	Monthly statistics derived from data from all years at 24 divided points along the NSR coast
		INSROP Phase 2	1953 - 90	Monthly statistics for each year at the points along the NSR at 20NM intervals
	Frequency of ice ridges	INSROP Phase 1	1947 - 89	Monthly statistics from 24 points distributed along the NSR, February to April and June to August
	Size of ice pack	INSROP Phase 2	1953 - 90	Annual and monthly statistics from the points along the NSR at 20NM intervals
Meteorological conditions	Air temperature	AARI	1964 - 94	Monthly statistics based on annual data from 232 points in the NSR
	Air pressure	US National Center / Hydrometeorological Center of Russia	1964 - 94	Annual and monthly statistics from 385 points in the NSR
	Wind direction	INSROP Phase 2	1953 - 90	Annual and monthly statistics from the points along the NSR at 20NM intervals
Sea/river	Tides	AARI	1956 - 95	Average flow speed and direction at 111 points throughout the NSR in summer
	river temperature	AARI	1961 - 89	Average monthly inflow volume
	Seawater temperature	AARI	1960 - 94	Average seasonal values (summer/winter) at 232 points in the NSR
Navigational information	NSR shipping route	INSROP Phase 2		Route data along the NSR (distance, depth, position, etc.)
	Shipping records	INSROP Phase 2		Navigational data
Infrastructure	Main roads	Digital Chart of the World		Line data
	Railways			Point and polygonal data
	Human settlements			
Environmental geography (distribution of ecosystems, etc.)	Icebergs	INSROP Phase 2		Point and polygonal data
	Ocean fish and river fish			
	Marine mammals			

4. Technological Aspects of NSR Navigation

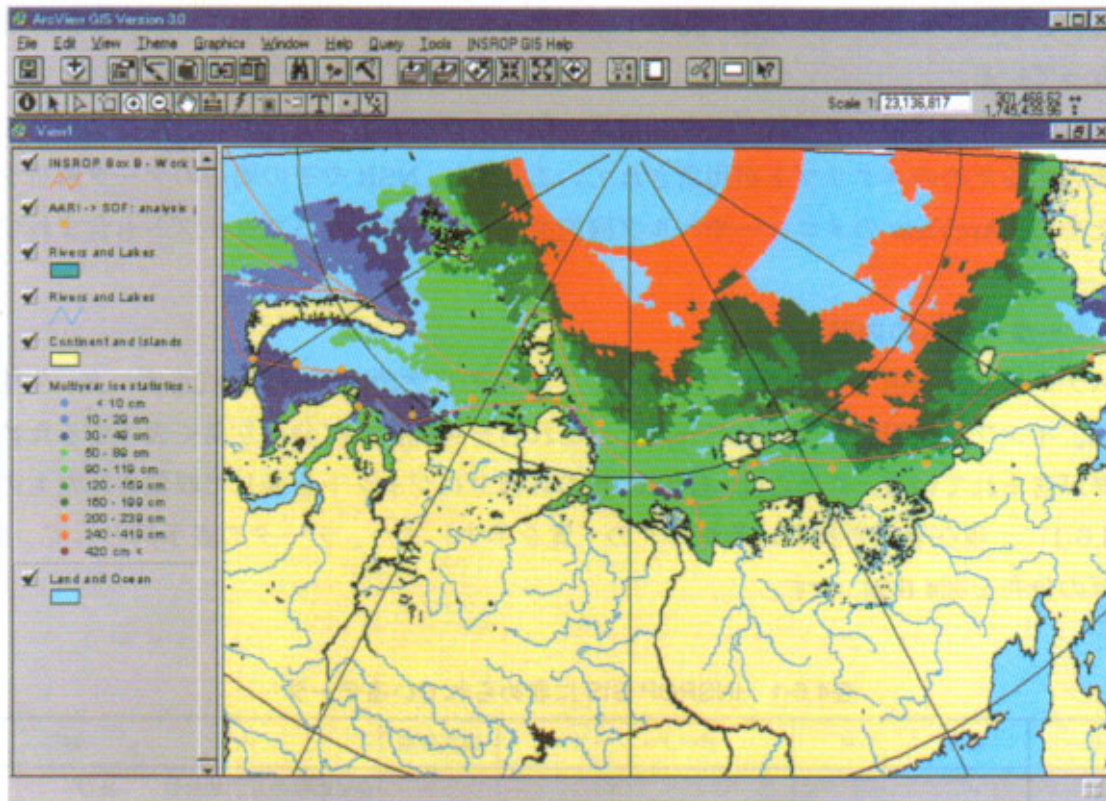

Figure 4.6-2 Example of INSROP GIS data display (average ice-thickness distribution in January)

[4] Oceanographic and river data

The following data are registered.

a. Tidal data

Average flow speed and azimuth angle are stored, utilizing the data on current measurement with moored buoys at depths of 5-10m in summer from 1956 to 1995.

b. River flow

Monthly average flow rates of selected Siberian rivers are stored.

c. Seawater density

d. Seawater salinity

[5] Navigation data

The segmented navigation data in the NSR are provided on the coordinates (longitude and latitude). Sea depths and distances between the coordinate-points are also registered.

[6] Infrastructure

These data include maps of major roads and railways and congested districts.

[7] Environmental geography

Biological data, gathered for use in environmental impact assessment, are stored. These include distributions of populations of mammals such as polar bears as well as birds and fish.

4.6.4 Application Examples

GIS is a powerful and flexible database application with proven value in a wide range of applications, but requires extensive practice to use the system properly. Even though INSROP GIS comprises a simplified menu for the NSR, it is almost impossible for beginners to perform all the specified analyses in the GIS. Although the GIS users' manual affords a detailed guide for operation and applications in practice, an example of the analysis

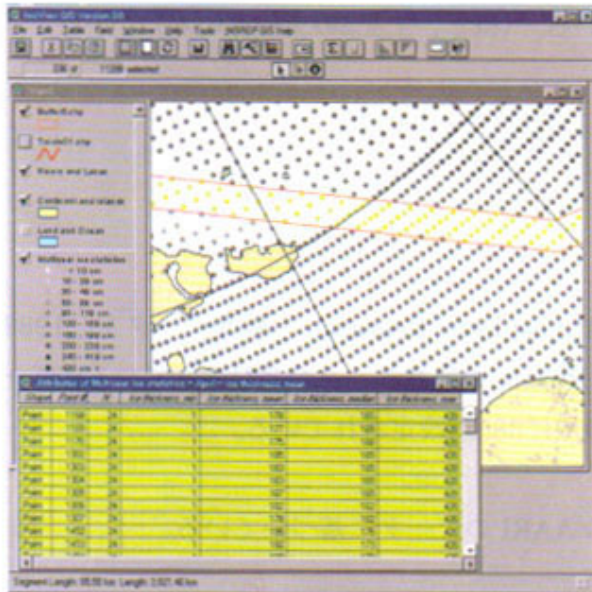

Figure 4.6.3 An application of INSROP GIS (Extraction of data along an assumed route)

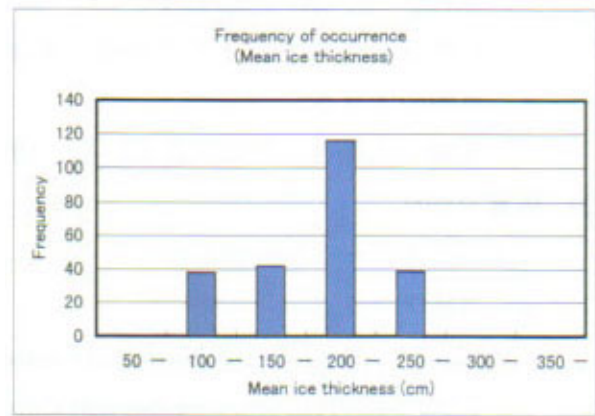

Figure 4.6.4 An application of INSROP GIS (Histogram of ice thickness along an assumed route)

performed by INSROP GIS is presented for better understanding: extracting ice data along a given route. Figure 4.6-3 shows an enlarged view of the western part of the East Siberian Sea. The line of dots in the map shows the points at which data were obtained. When an assumed route with a certain band width is plotted, the data at the points inside the route-band are indicated. In the diagram, the assumed route is indicated in red lines. The data points inside the route-band appear as yellow dots, and a table within the diagram shows a list of the data on the assumed route. Using one of the functions of the GIS software, simple statistical processing can be performed on these data. Figure 4.6-4 shows a histogram illustrating the frequency distribution of ice thickness on the route. In addition to the data processing by the basic GIS software, ordinary statistical analyses can be also carried out by preparation of scripts registered in the menu as the occasion demands.

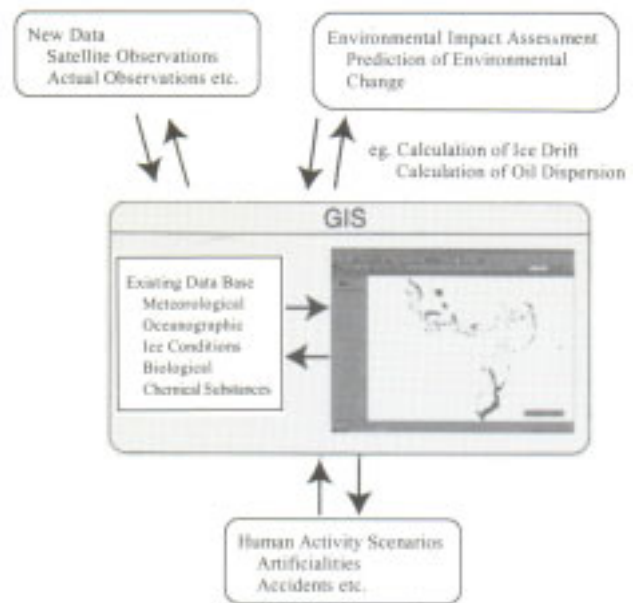

Figure 4.6.5 Schematic diagram of environmental impact prediction and assessment in the use of the GIS

Although simple data processing such as the examples above can be performed on ISNROP GIS software, for more complex calculations, such as numerical forecasting, the GIS must be linked to external software applications. Because the GIS is a database software, its interface was designed to accommodate such external processing. Many application software can work with the GIS through a dynamic link function. The GIS can also input and output data to and from many major file formats, such as text, Excel and dBase files, so that data can be shared even without dynamic link function. Figure 4.6-5 shows a schematic diagram of one possible use of these features, in which the GIS is used as a database and viewer in a system for forecasting and evaluating environmental changes. This illustration shows the potential for the GIS in future environmental impact

4. Technological Aspects of NSR Navigation

assessment systems and as a basic technology in sustainable, environment-friendly development. Moreover, INSROP GIS can be linked with other GIS systems to exchange information for a wide variety of uses, such as policy proposals at the national and regional level, planning of the activities of various agencies, and exchange of opinions and decision-making on specific scenarios. Such linkage will also enable researchers to revise, update and supplement data as well as expand the program's functions, on a constant or regular basis.

5. Experimental Voyage through Northern Sea Route

5.1 Introduction

Although INSROP conducted extensive studies to evaluate the viability of the NSR, most of its projects consisted of "desk-work," such as the preparation and organization of databases. For its part, SOF conducted its own exclusive R&D project to design the icebreaking cargo vessels optimized for NSR shipping, based on extensive model tests. Model tests and sufficient environmental data on the operation route are vital under current procedure to design the optimum hull form for given specifications of a ship, for which excellent navigational performance can be expected in actual service on the route. In any case of development of a new sea lane, however, practical experience in navigation, or at least in experimental voyages, in the lane are indispensable to confirm the ship performance and find realistic solutions to unpredicted problems encountered in the actual operation. Extremely few voyages in the NSR have been conducted by vessels with non-Russian flags, and even those were under the command of Russian seamen. With these reasons in mind, SOF conducted an experimental voyage through the NSR in the summer of 1995, with backing from The Nippon Foundation. The objectives of this experimental voyage were to perform a comprehensive assessment of the conditions under which NSR navigation would take place, through actual sailing experience in the NSR, to obtain quantitative data of overall ship performance, and to evaluate the satellite-base ice information system as well. The information gathered must then form the basis for future R&D activities to ensure safe and efficient NSR operations.

The first Western-funded commercial voyage through the NSR since Secretary Mikhail Gorbachev declared the region open to the international shipping on October 1, 1987 (see Section 2.2) was the voyage of the Tiksi, an SA-15 class icebreaking cargo ship, sister ship of the Kandalaksha (see Section 4.1.2 (1)), chartered by the Hamburg shipping firm Detlef von Apen. The Tiksi voyaged from Hamburg to the Japanese port of Chiba, laden with a 14,109 t cargo of metal (Matyushenko, 1992). Departing the port of Hamburg on July 12, 1989, the Tiksi reached Chiba on August 4. This ship traversed the NSR from Europe to the Far East several times thereafter, in the summer months from July to October. In 1991, the French observation ship L'Astrolabe became the first Western flag ship to complete the entire voyage through the NSR, crossing the region from west to east. Unlike the Tiksi, however, L'Astrolabe was a small vessel of only 950 t, and its voyage seemed more of a demonstration than a commercial undertaking. After the 1995 SOF test described above, the Finnish ship Uikku left port in the fall of 1997 carrying a cargo of diesel oil to become the first Western freighter to navigate the NSR as far as the port of Provideniya (Saavala, 1999). Other recent attempts using non-Russian vessels have yielded valuable results as well, with ships hailing from Latvia, Finland and Germany.

Although the SOF adopted a Russian vessel in the experimental voyage, the test journey provided an opportunity for an international team of researchers, composed of specialists and experienced academics from a wide range of disciplines, to join a commercial voyage on a ship laden with cargo, and to objectively evaluate the voyage from various aspects. The SOF team gathered valuable basic data on the natural environment of the NSR and the ship performance in ice-covered waters.

5.2 Test Planning

The ship selected for the experimental voyage was an icebreaking cargo ship of the SA-15 class (also called Norilsk class, after the name of the first ship in the series), Russia's premier class of icebreaking cargo vessels. The SOF decided to conduct a test voyage from Japan to Europe, laden with cargo. As described in Section

5. Experimental Voyage through Northern Sea Route

4.3.2, the Russian government normally must be notified four months in advance of any planned voyages through the NSR, according to the Russian government publication "Guide to Navigating through the Northern Sea Route." However, because this voyage included objectives of a scientific nature, six months' advance notice was required, as stipulated in Cabinet Order 400 of the Russian Republic, "Approval of Temporary Regulations of Granting Permission for Scientific Research Activities and Sightseeing Cruises in the Contiguous Zone to the Arctic Coast of the Russian Federation".

To expedite approval of the voyage, meetings and discussions were held with CNIIMF, Russian partner of INSROP, to settle the request to be submitted by the Russian agency. On March 30, 1995, the approval was duly granted. Negotiations were held five times with the owner of icebreaking cargo ships, MSC, before a charter contract was signed in June 1995. Finally the SOF chartered the Kandalaksha. One of the nineteen SA-15 class ships built from 1982 onward, the Kandalaksha is a multi-purpose icebreaking cargo ship constructed in Finland, with a length of 174 m and cargo capacity of 14,700 tons at the Arctic subdivision loadline (Figure 5.1). The Kandalaksha belongs to the ULA class, the highest ice class of the current Russian freighters. After loading 14,000 tons of magnesite in China and 4,000 tons of boric acid in Russia, the vessel anchored at Yokohama for preparation of the experimental voyage. During the three days before the Kandalaksha left port on August 1, sensors were mounted and connected with the measuring instruments and data acquisition/analysis devices were mounted as listed below. Finally, the overall system was thoroughly checked. The locations of sensors are illustrated in Figure 5.1. All sensors were linked to a measuring center in a room, where recording and analytical work were to be carried out. The following equipment was taken on board:

- * GPS and a PC: To determine ship position, speed, turning radius, etc.
- * Modem and PC system: Installed in the radio room, to receive digital data of satellite ice images
- * Accelerometers: Three sensors at the bow and two at the midship to measure the accelerations of the ship in ice.
- * Vertical gyro: Installed in the measuring center to measure pitch and roll of the ship
- * CCD-TV cameras: Two in the bow and one on the side, to monitor ice conditions and ice-breaking phenomena and for measurement of ice concentration and thickness by image processing.
- * Shaft Power Meter: Mounted on the propeller shaft to measure shaft thrust, torque, rate of revolution and shaft horsepower.
- * Pressure transducers: Four transducers for measurement of the rudder piston pressure to estimate rudder torque.
- * Analog data recorders and PC systems: Installed in the measuring center to acquire and analyze sensor signals.
- * An electroconductivity meter, a refraction salinometer: to measure the salinity of seawater.

A notable feature of the experimental NSR voyage of the Kandalaksha was the opportunity to conduct a wide variety of quantitative measurements on a freighter under full cargo.

Major scientific and technical activities carried out on this test voyage were as follows.

- [1] Ship's logs written in Russian were translated into English and analyzed. All information on ice conditions along the route is recorded for inclusion in basic data. These data were used for comparison with existing navigational results in published reports to evaluate the experimental voyage throughout.
- [2] Satellite images of ice conditions were received successively during the voyage to study their applicability to rational navigation in the NSR.
- [3] Propulsion performance and turning tests were carried out to provide their quantitative data and assessment of the SA-15's navigation performance in ice-covered water.

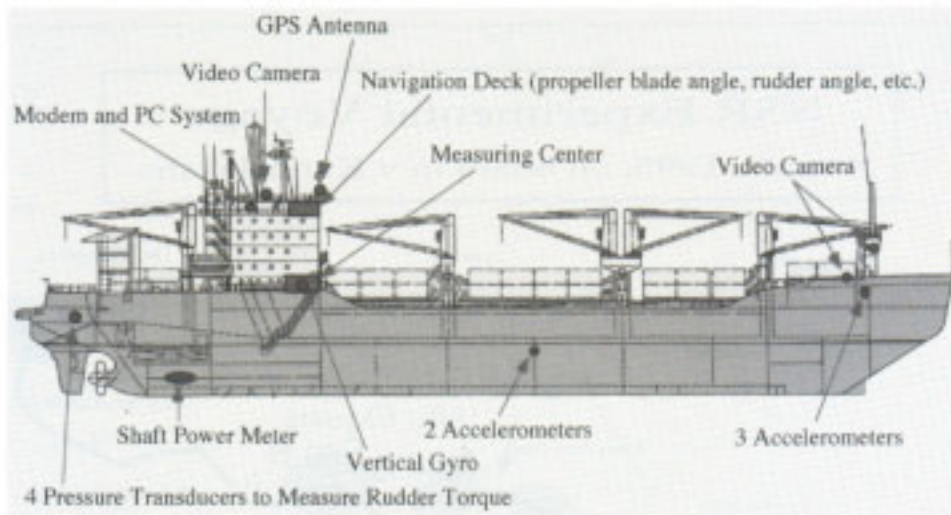

Length	174.0m	Cruising distance	16000NM
Length between perpendiculars	159.6m	Tank capacity:	
Molded breadth	24.0m	Heavy fuel oil	3740m ³
Molded depth	15.2m	Diesel oil	783m ³
Draft (summer loadline)	10.5m	Lubrication oil	85m ³
Draft (Arctic subdivision loadline)	9.0m	Drinking water	174m ³
Dead weight (summer loadline)	19442ton	Fresh water	501m ³
Dead weight (Arctic subdivision loadline)	14700ton	Water ballast	972m ³
Main engine	2 × Wartsila Sulzer 14ZV 40/48	Number of passengers and crew aboard	52persons
Output	2 × 7700kw(21000BHP)		
Propeller	1 × CPP, 4 blades, diameter = 5.6m		

Figure 5.1 Principal particulars of the Kandalaksha and location of sensors and instruments on board

- [4] A number of engineering issues in the NSR operation were clarified in the course of the voyage and discussions were held with the crew regarding their experience in NSR navigation.
- [5] In addition to the measurement of salinity and temperature of the seawater, meteorological observations such as air temperature, air pressure and cloud formation were conducted to study the natural conditions along the route.
- [6] The feasibility of the NSR as a commercial sea lane was discussed on the basis of the data obtained from this voyage and the available literature, as well as the opinions of crew members on board.
- [7] The SOF mission party for the experimental voyage included a professional TV and video director and camera crew, who recorded the party’s activities and produced documentary videos in English and Japanese.

To fulfill this multiple mission, the SOF selected an international team of eighteen members for the voyage, consisting of 15 Japanese, 2 Russians and 1 Canadian. All members were experts in their respective fields, such as naval architecture, navigation, instrumentation, oceanography, meteorology and hydrography. These experts collaborated closely with the crew to carry out all observation, measurement and analytical tasks on the mission program successfully. Firmly committed to the objective of opening the NSR to substantial traffic, Captain Sokolov and all 31 Russian crewmembers surmounted the formidable language barrier between the crew and the international experts to make an important contribution to the experimental voyage.

5.3 Test Results

In this experimental voyage, the Kandalaksha left the port of Yokohama on August 1, 1995 and reached the

5. Experimental Voyage through Northern Sea Route

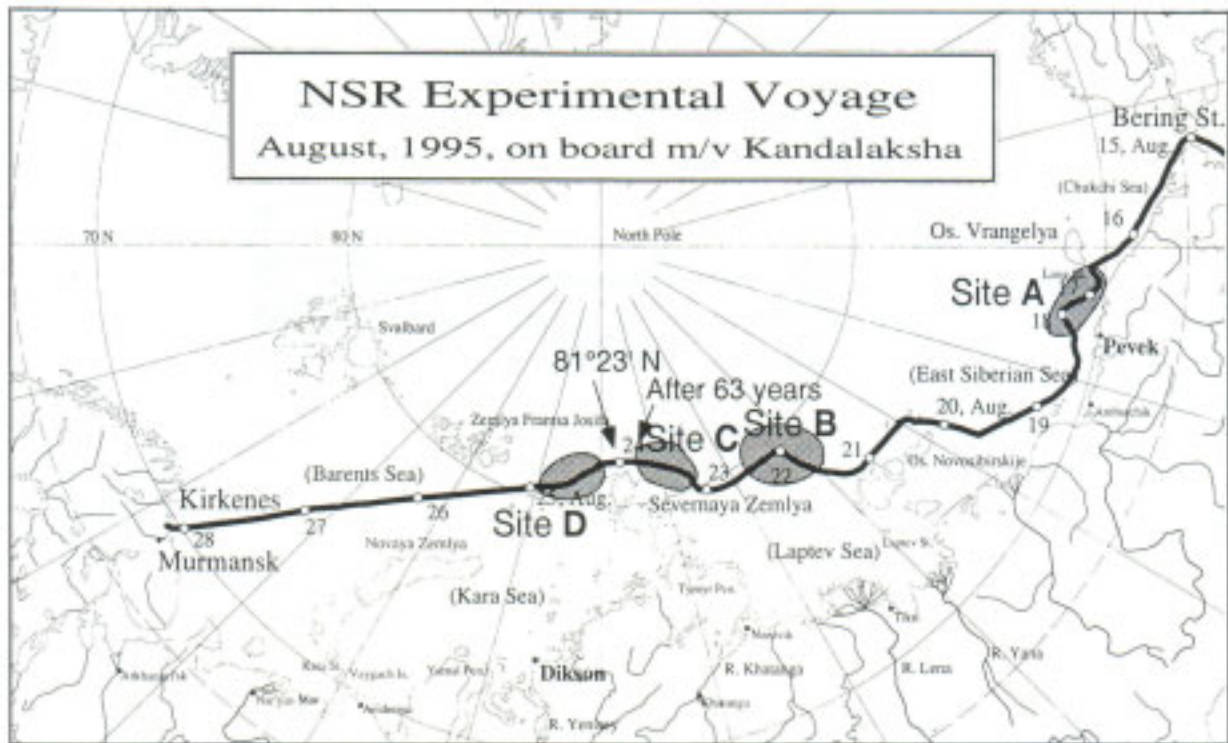

Figure 5.2 Route of the Kandalaksha and test sites: Sites A-D
(Numbers indicated along the route are dates, indicating the position of the ship at noon (ship time) on the date shown.)

northern Norwegian port of Kirkenes on August 28, completing a successful voyage. The ice conditions were highly unusual in 1995. According to information from the Russian scientists included in the team on board, the ice conditions in the eastern part of the NSR at the end of July were one of the two worst on record since 1948. Fortunately, at the time the Kandalaksha crossed the Bering Strait in mid-August, a persistent cyclone over the Arctic Ocean generated a steady southwesterly wind, which drove out almost all ice from the ordinary NSR region off the Siberian coast. Because one of the primary objectives of the voyage was to evaluate the ship performance under severe natural conditions in the Arctic Ocean, the mission team decided to take a northerly course to find appropriate ice conditions for the ship performance test. The route taken by the Kandalaksha after passing the Bering Strait is indicated in Figure 5.2. In Figure 5.3, a photograph shows the Kandalaksha performing a speed test in ice.



Figure 5.3 The Kandalaksha performing a speed test in ice, August 22, 1995

The trend in hourly average speeds is illustrated in Figure 5.4. Although the Kandalaksha was equipped with two engines, to save fuel costs only one engine was in operation under normal conditions. Under single-engine operation in calm seas, the ship speed was approximately 12 knots; with two engines, the speed was boosted to 14 knots. The total sailing distance from Yokohama to Kirknes was 6,887 NM, and the ship run at an average speed of 11 knots. At Site A (near Wrangel Island: as shown in Fig. 5.2) in ice-infested waters, the

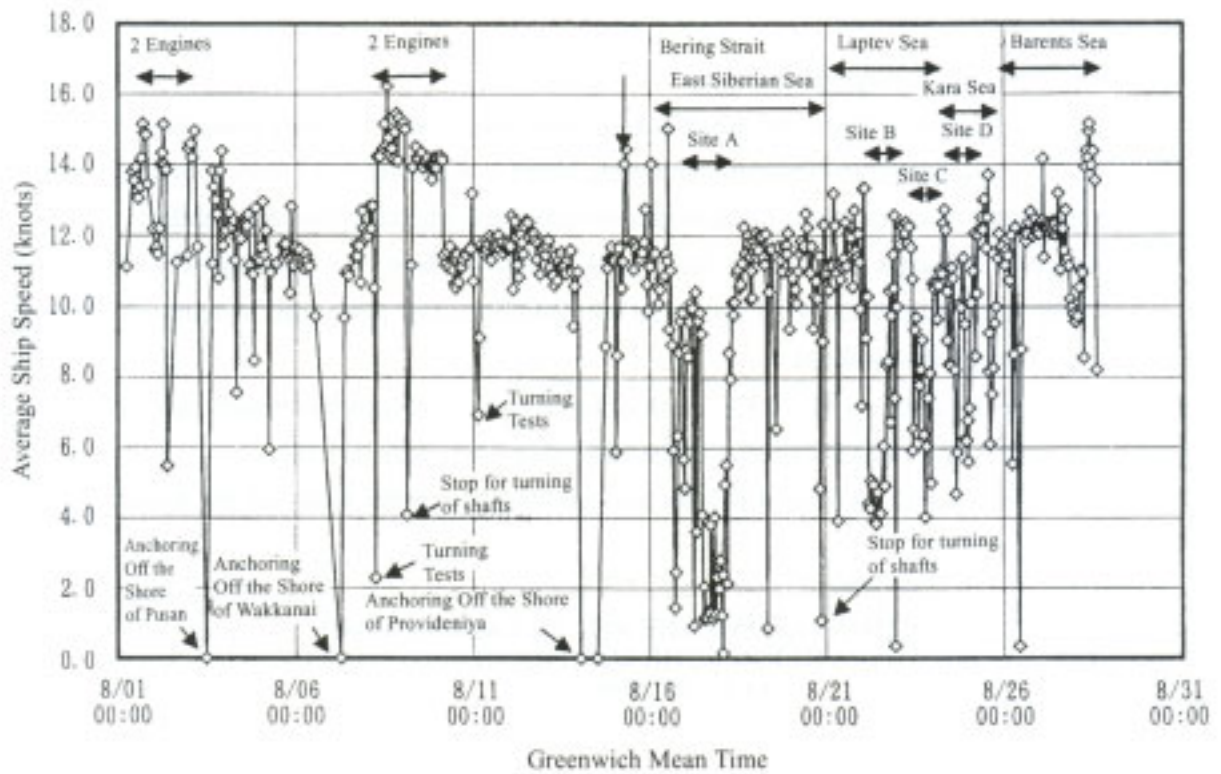

Figure 5.4 Average ship speed per hour of navigation

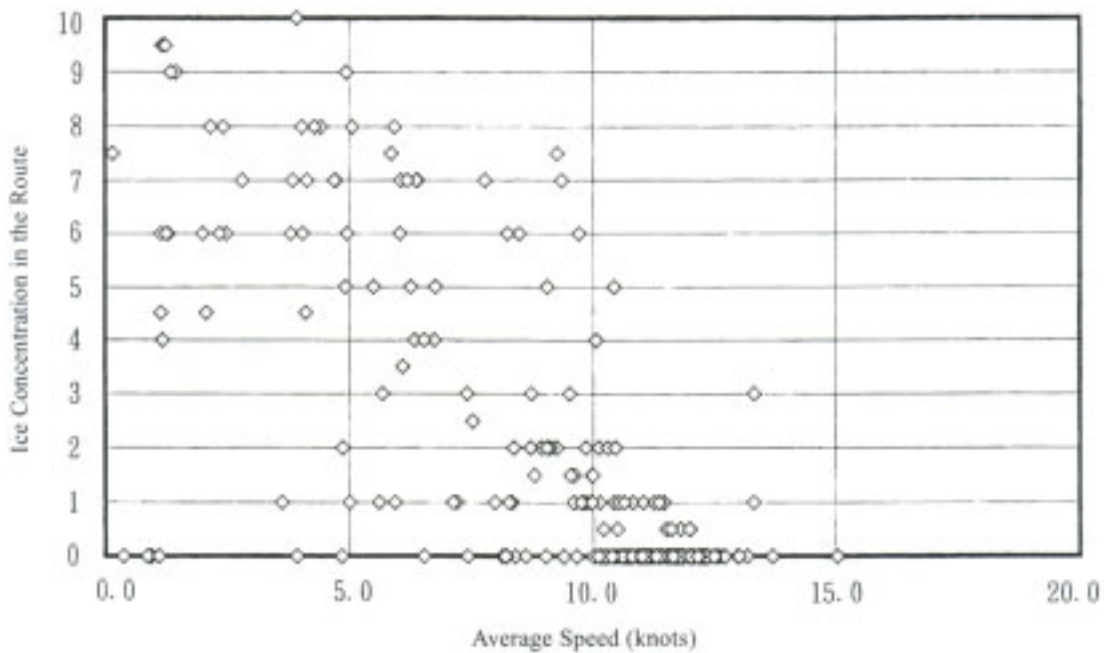

Figure 5.5 Dependence of ship speed upon ice concentration

Kandalaksha attained a speed of 8-10 knots in the first half of the area with relatively low ice concentration and 2-4 knots in the latter half with high ice concentration. Site A, abundant in multi-year ice floes, presented the severest ice conditions of the entire voyage (see the description of the Ion Ice Massif, Section 3.2.3). In the other sites, the ship speeds were 4-5 knots at Site B, 6-8 knots at Site C and 8-10 knots at Site D (see the description of the Taymyr Ice Massif and North Kara Sea Ice Massif, Section 3.2.3). As Figure 5.5 shows, ship speed is dependent on the ice concentration, so that speed decreased as ice concentration increased. It should be noted that the Kandalaksha experienced no continuous vast or giant floes but only small and medium floes

5. Experimental Voyage through Northern Sea Route

throughout the voyage.

Other major results of the voyage are as follows.

- [1] By selecting a more northerly route, the Kandalaksha was able to take a shorter route than the usual NSR (Figure 4.2-6), traveling the 3,140 NM from the Bering Strait to Kirkenes in 13 days. Considering that these voyage-days included three extra days for activities to record documentary film and conduct research work, the direct voyage to Kirkenes could have been made within 10 days. The Kandalaksha's rapid progress through the NSR was partly because of favorable ice conditions and partly due to optimum routing with information delivered by the satellites.
- [2] The ship ventured as far north as $81^{\circ} 23'N$, north of Severnaya Zemlya, without icebreaker support, which had not been accomplished since the voyage of the steamship Sibiriyakov in 1932.
- [3] The Russian members kept a 24-hour watch for ice conditions from the bridge of the Kandalaksha. Their

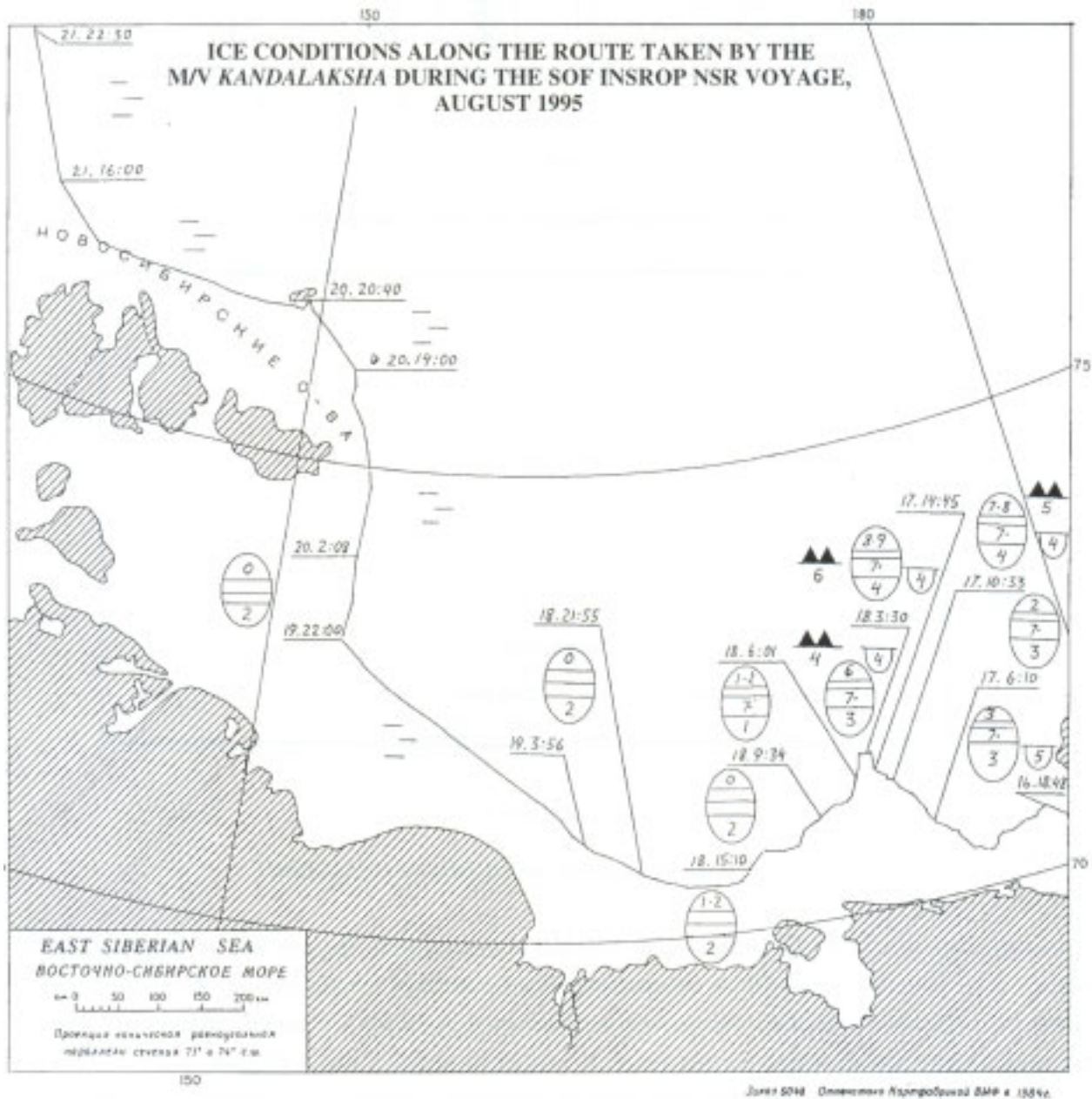

Figure 5.6 Example of results of ice observation (East Siberian Sea): Markings according to the International Standard Symbols (For international markings of sea ice, see Appendix 4)

observations were incorporated into a data sheet by the Russian and Canadian members and used to calculate the ice numerals (see Appendix 5-2) recently defined in the Ice Regime Control System of CASPPR in Canada. Maps of ice conditions were also prepared according to international standards; as an example, the map of ice conditions in the East Siberian Sea is shown in Figure 5.6. The mission experienced navigation in icy waters for only 6.5 days, including a smooth voyage in the presence of sparse small ice floes. No level ice or vast uniform ice floe was encountered. With the aid of image-processing, the records captured by the video cameras mounted on the ship provided the data of ice concentration and ice thickness, which were then carefully examined and compared with the visual observations mentioned above.

[4] Through close liaison with Norway's Nansen Environmental Remote Sensing Center (NERSC), the Kandalaksha obtained a continuous feed of two types of satellite image from this laboratory during its voyage. One type of image was delivered from the synthetic-aperture radar (SAR) mounted on the ERS-1, a European satellite used in exploration for natural resources. These images delivered superb spatial resolution, but covered relatively narrow swaths of about 100 km (see the example in Figure 5.7). The other series of images was captured by a Special Sensor Microwave Imager (SSM/I) belonging to the US National Ocean and Air Agency (NOAA) and transferred to NERSC for interpreting of the data into ice mapping. Although the spatial resolution of the SSM/I images was lower than those from SAR, the data covered a much wider area. These ice maps were transmitted to the

ship by facsimile via the INMARSAT communication satellite. The same telephone line was also used to provide an Internet connection that delivered the original images with high quality. The locations at which these satellite images of ice conditions were taken and each coverage of SAR and SSM/I data are shown in Figures 5.8 and 5.9. The SAR sensor installed in the Canadian RADARSAT satellite which provides a maximum observation swath of 500 km, is expected to be highly effective in the NSR. For the moment, however, these images are extremely expensive.

The Kandalaksha benefited from other sources of ice data as well. The Maritime Operation Headquarters at Pevek and Dikson provided the Kandalaksha with two types of data on ice conditions. One type consisted of numerical flight reconnaissance data sent from Pevek by telex. One of the Russian experts of the mission team analyzed the data to create ice maps. The other source of data, obtained from the Dikson Headquarters, was a hand-drawn ice map based on data from the Russian OKEAN-1 observation satellite.

[5] Discussions and decisions about the ship's specific route were based on these data on ice conditions. Because this voyage followed a more northerly route than usual, the SAR image data were unfortunately of almost no use in determining the ship's route. This is because the time and position of the images captured by the SAR have to be booked months in advance. Compensating for this loss was the great utility of the

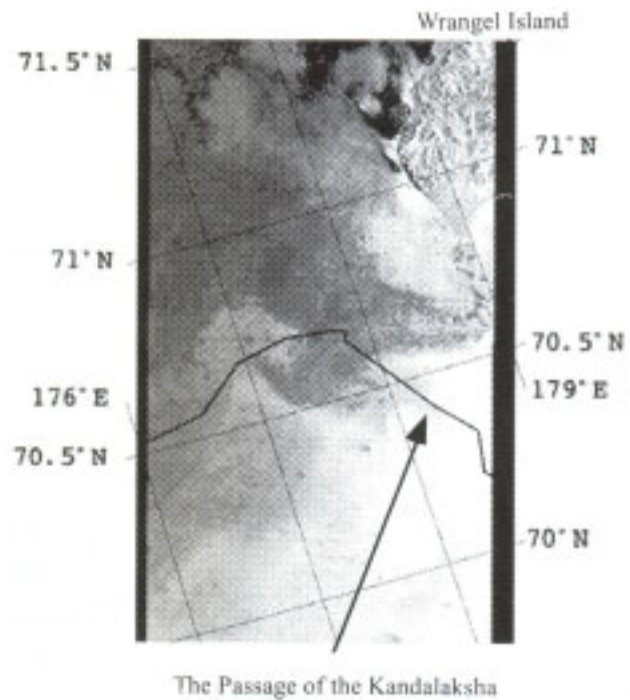

Figure 5.7 An example of SAR image (Southwest of the Wrangel Island , 1995.8.17)

5. Experimental Voyage through Northern Sea Route

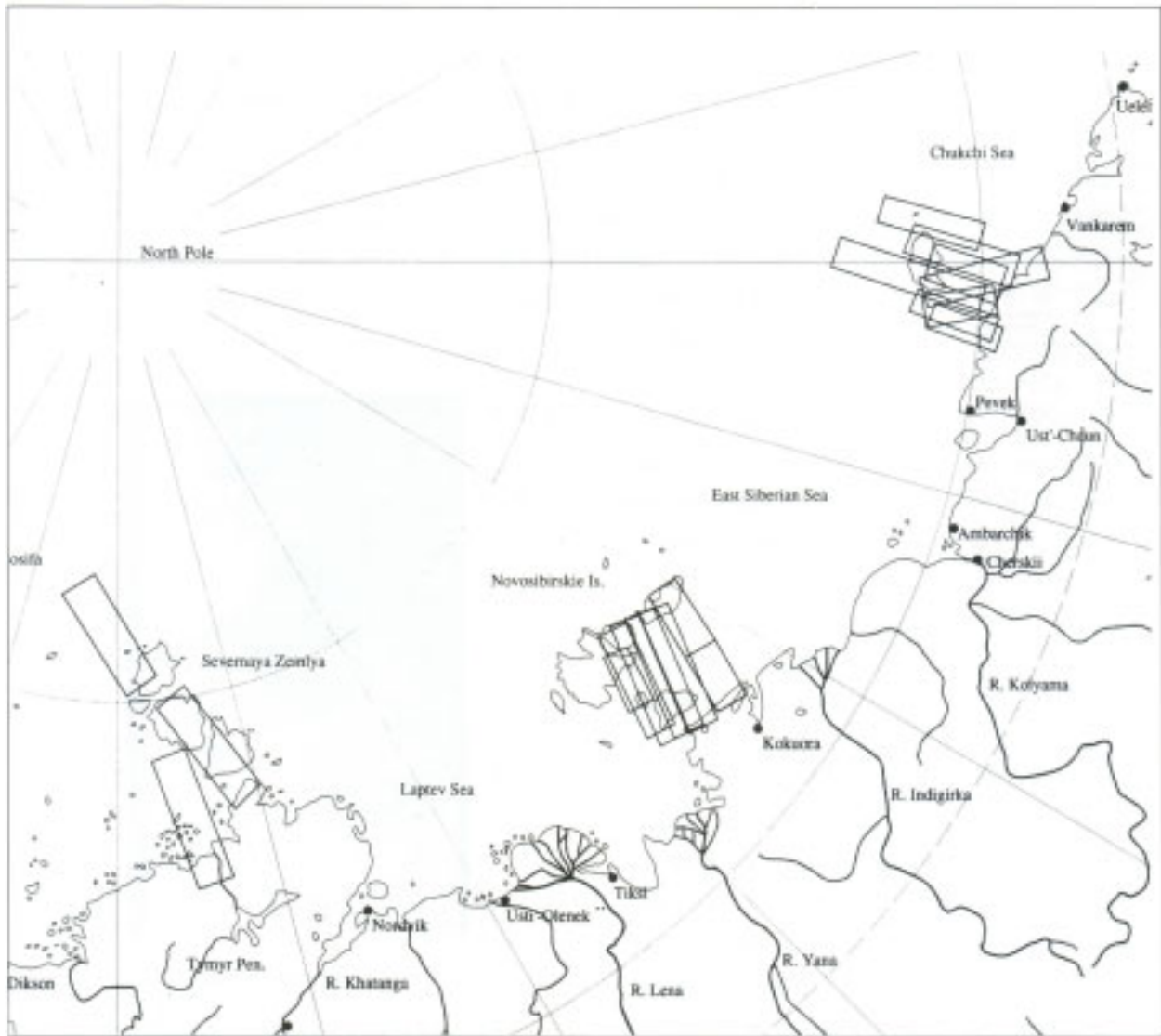

Figure 5.8 Coverage of SAR data

SSM/I images and the Russian ice maps, which were instrumental in enabling the ship to voyage in the north of Severnaya Zemlya without icebreaker escort. Moreover, such data will be immensely valuable in short-term predictions of ice conditions. Particularly on this voyage, suggestions given by the Captain and Russian scientists were highly valuable in determination of the ship course. By combining this experience-based forecasting with numerical forecasts made by computers using satellite information, future navigators will be capable of predicting ice conditions with great efficiency and accuracy.

Although the SSM/I images were extremely useful on this voyage, their low spatial resolution of 25 km provided insufficient information on ice conditions. The SSM/I data should eventually be utilized for medium-to-long-range planning of route selection, longer than a period of a day, and also as complementary data for use in obtaining particular data in detail from SAR. The usefulness of SAR would be greatly enhanced if it were combined with the wide-area images to be provided by the RADARSAT and ICESTAR programs. By improving the accessibility and availability of the data, together with validation of accumulated in-situ data, an algorithm of conversion of SAR image signals into ice maps should be developed for safe and reliable NSR operation in future. Data backed by the wealth of experience of Maritime Operation Headquarters of Russia can be used with a great deal of confidence. Unfortunately the

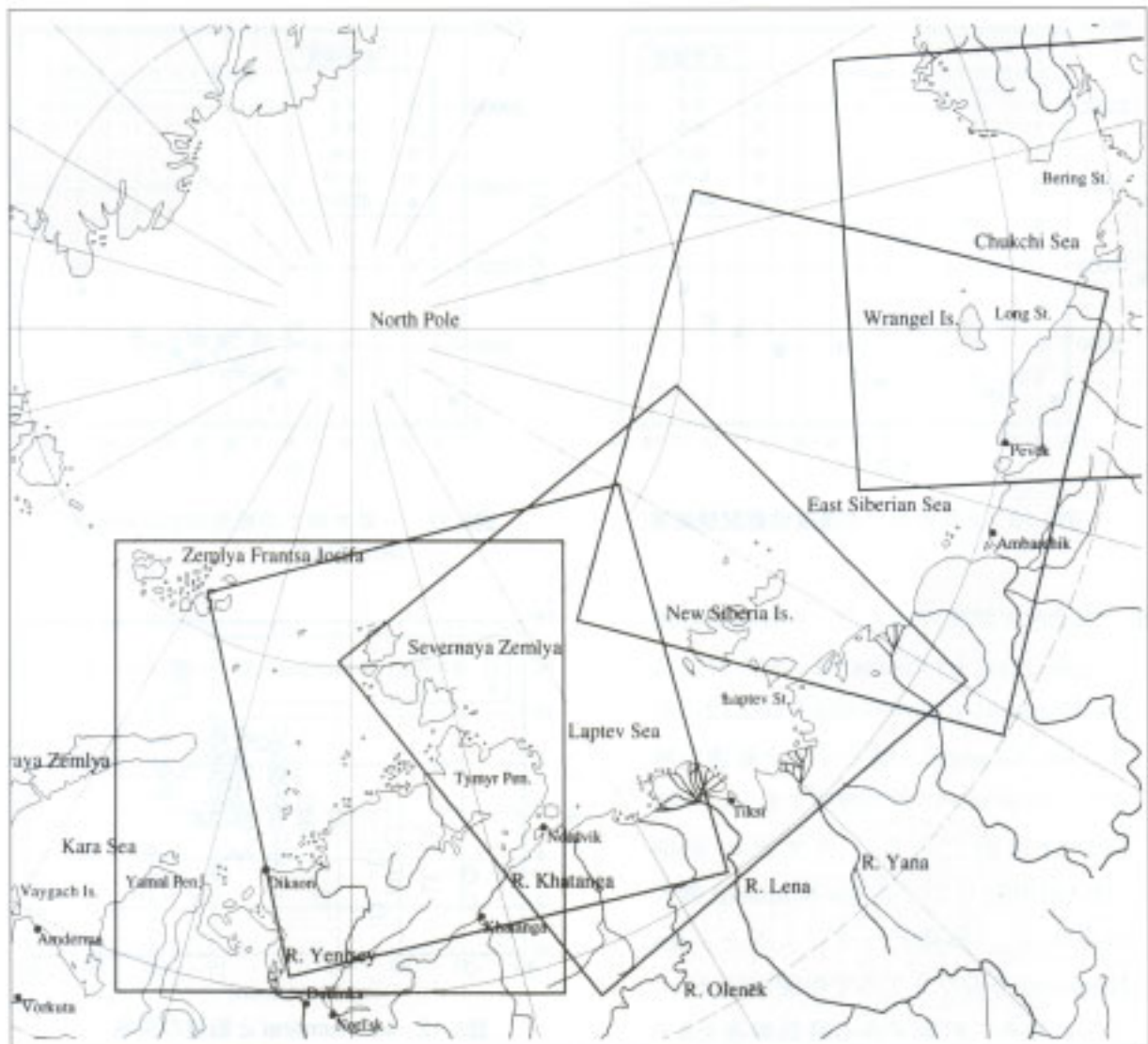

Figure 5.9 Coverage of SSM/I data

present confusion in Russia's political state is choking off the supply of this information. Because reliable information of ice conditions is essential for navigation in ice, preparation of the necessary infrastructure and its maintenance are issues of paramount importance.

- [6] The voyage underscored the importance of information on navigation aids, particularly on ice conditions. Throughout most of the Laptev Sea, however, communication via INMARSAT broke down (Figure 4.2-10). To solve this problem, transmission facilities or stations need to be upgraded along Russia's northern coast. Notification of the route selection of the NSR is requested one month prior to leaving port, which means that route selection in advance of any voyage must be made on the basis of forecasts on ice conditions for the entire NSR one month forward. The responsible public authorities should duly undertake the responsibility to provide this information service.
- [7] To obtain the quantitative data of the ship performance in ice and open water, propulsion and turning tests were conducted, using sensors and instruments on boards such as shaft power meter, gyro and other various measuring devices. Approximately 150 tests in total were carried out at sites A to D, as shown in Fig. 5.2. The data from these instruments were recorded and analyzed automatically by equipment in the measuring center in the ship, so that as much analysis as possible could be conducted on board. Results of the

5. Experimental Voyage through Northern Sea Route

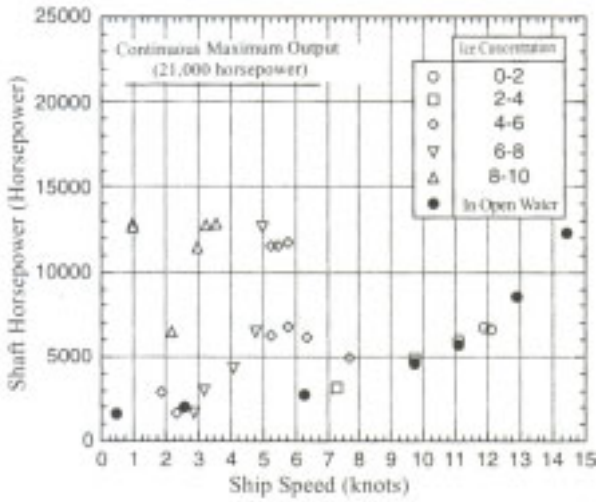

Figure 5.10 Propulsion performance in multi-year ice (Site A)

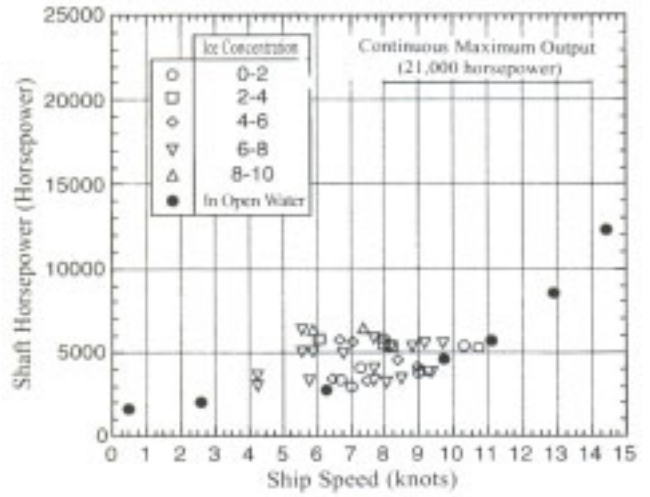

Figure 5.11 Propulsion performance in first-year ice (Sites B & C)

propulsion performance tests appear in Figures 5.10 and 5.11. The propulsion performance in ice was tested in the multi-year floe in the East Siberian Sea and the first-year ice in the Laptev Sea and Kara Sea.

Although the maximum continuous rating of the main engine installed in the Kandalaksha was 21,000HP, the measurements indicated that maximum horsepower under the most rigorous conditions of multi-year ice was 13,000HP, delivering speeds of 1-6 knots. The engine was originally designed for navigation through the year in the NSR and anchoring at Russian ports. However, the results of the experimental voyage suggest that for the purposes of NSR transit shipping, this rating was inappropriate - excessive for the summer and insufficient for winter navigation.

[8] The results of the propulsion performance tests were correlated with the ice numerals obtained from the ice observation results. In Figure 5.12, each ice numeral is correlated with ship speed. As expected, this correlation was positive: as the ice numeral decreases, so does the speed of the vessel, requiring greater output from the engine. Canadian ice numerals introduced into the regulations (CASPPR) was based on the operation experience that an average ship speed in

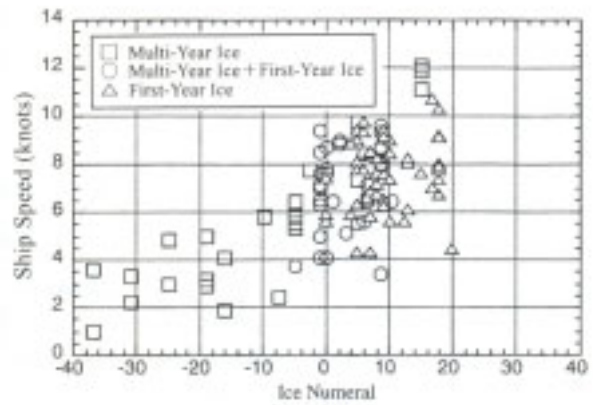

Figure 5.12 Correlation between ice numeral and ship speed

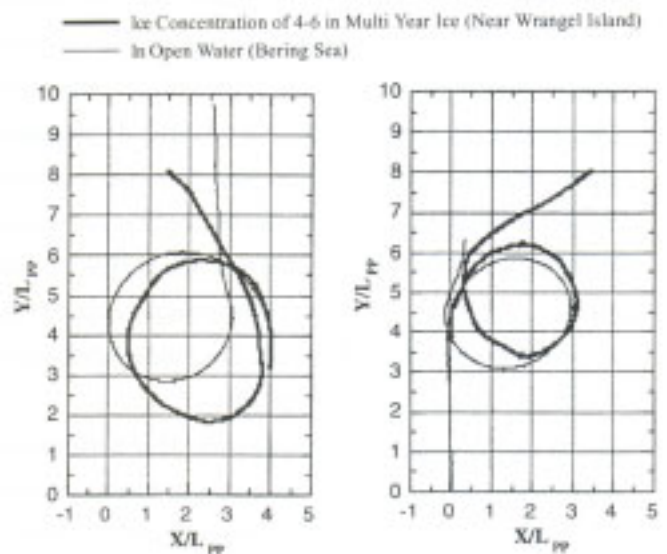

Figure 5.13 Turning performance in multi-year ice (Site A)

statistics was 3 knots at the ice numeral of 0. Since this speed is considered the critical speed at which a ship could usefully operate, the regulations define that at ice numerals less than 0 the ship is considered to be navigating dangerous waters. In the experimental voyage, however, the Kandalaksha delivered speeds of 4–9 knots at an ice numeral of 0, indicating that the Canadian ice numeral is set more conservatively (with a higher safety margin) than anticipated. For summer navigation in the presence of melted ice, CASPPR would normally correct its formula for calculating the ice numeral. The Kandalaksha’s results suggest that a greater correction for the ice numeral may be possible.

[9] The tactical diameter in ice concentration of 4-6 was roughly the same as in open water (Figure 5.13). However, in more severe ice conditions the ship was unable to manage a 360° turn.

[10] As a rule, measurements were conducted at three-hour intervals of natural conditions such as meteorological, hydrological and ice conditions as well as salinity of the surface water. Variations in salinity along the route are shown in Figure 5.14. Salinity along the coast from the Sea of Okhotsk to the Bering Sea is approximately 3.2%, a value in the normal range, but upon entering the Chukchi Sea salinity values dropped precipitously, falling to a low of 0.2% in the East Siberian Sea. The causes of this phenomenon are thought to be melting of ice and especially the inflow of fresh water from the rivers of the mainland. In some locations, particularly the boundary between the Chukchi Sea and East Siberian Sea, sudden changes in salinity are observed, where turbulent vortices are generated by the complex interactions of river flows and ocean currents.

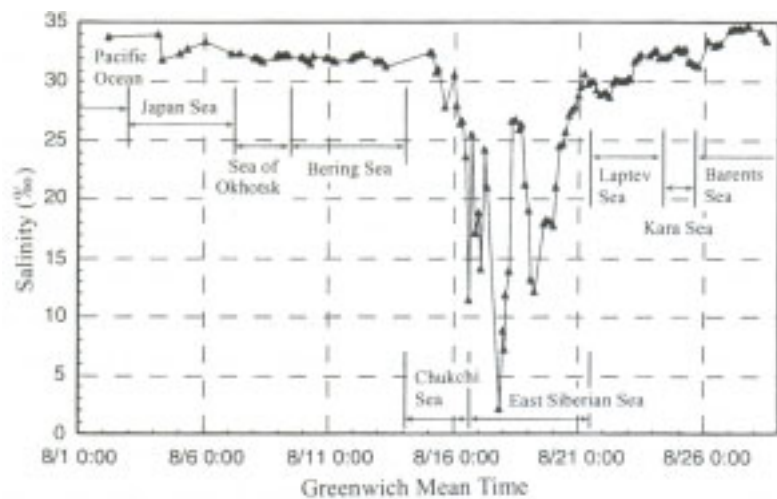

Figure 5.14 Variations in the salinity of surface water

While the ship followed a course further offshore, salinity again rose and became much more uniform. Each sea has its characteristic sea surface temperature and salinity. Water masses in these seas can thus be divided clearly in the T-S diagram (Figure 5.15).

[11] Documentary videos 35 minutes in length were produced in Japanese and English, detailing the various activities of the mission team on the Kandalaksha and the details of the tests they conducted.

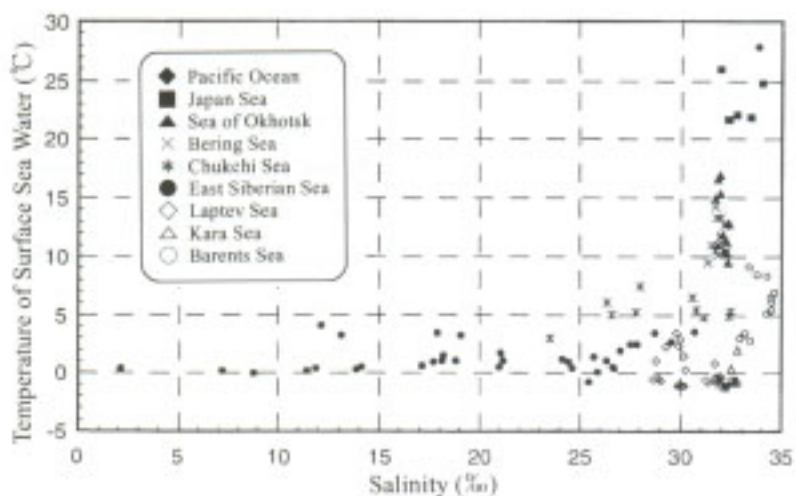

Figure 5.15 Relationship between salinity and water temperature in surface water

5.4 Conclusions

The historic experimental voyage was summarized in the foregoing section. The unusually favorable ice conditions in the NSR persuaded the international members to sail north in search of ice appropriate for performing the tests in the plan. This turn of events resulted in the recording of an unexpectedly short journey, in the first unescorted voyage north of Severnaya Zemlya in 63 years. Under these conditions, it might be said that even an ordinary (non-ice-breaking) vessel could easily have traveled the normal NSR coastal route (although in practice this is contrary to regulations; see Section 4.3.3). Of course, a single journey alone is not sufficient to determine the feasibility of opening the NSR to commercial shipping, but it did prove that summer navigation can be much easier than people have imagined, and provided quantitative grounds for assessment of the navigation performance of Russian ships under full cargo in Arctic waters. These results are sure to contribute to the development of the shipbuilding and marine shipping industries, not only in Japan but around the world. Moreover, the voyage clarified the utility of ice information in Arctic navigation and highlighted some of the problems involved in communications in the NSR.

A Russian vessel was chartered for the purpose of this voyage. The captain of the vessel was a seasoned mariner, experienced in seafaring in the NSR as well as overseas, and his fluent English kept communication problems to a minimum. Some concern arose with respect to the young sailors and engineers, who had no experience in Arctic waters and little grasp of English. Similarly, if an icebreaker escort were needed it is likely that the captain would speak little or no English, since their job is viewed as a matter of domestic shipping. Although foreign ships are to be assigned ice pilots who are reasonably fluent in English (see Section 4.3.4), Russia has its own methods and approaches in training sailors, so the possibility of miscommunication between the foreign cargo ship and the icebreaker raises some cause for concern. The general consensus among the mission team is that further similar experimental voyages in different seasons, especially with non-Russian vessels and crew, are vital for the substantial opening of NSR as an international sea lane. At this point, the Russian authorities are working hard to supply crews with sufficient proficiency in English, and are doing their best to remove any obstacles.

In general, Russia's technology for navigating Arctic waters is impressive, and the level of its support framework is exceptionally high. Nonetheless Russia's protracted economic turmoil has engendered a serious decline in NSR shipping and has exacerbated the obsolescence of its facilities. The poor state of maintenance of those facilities is a cause for grave concern.

There already exist several examples of NSR navigation by the vessels of countries other than Russia. None of these, however, were conducted with the stated intent of opening the NSR to international commercial shipping. These countries already benefit from close diplomatic relations between Russia and other European countries and completed their voyages without any reference to East Asia. This voyage will have a significant impact on Asian countries, both far east and central, and on Europe as well.

This chapter was written with reference to the following report:

"Experimental Voyage through Northern Sea Route", Report of the Project for the Research on the Northern Sea Route, Ship & Ocean Foundation, 1996.

6. Issues to be Resolved for NSR Operation

6.1 Related Technology

All technologies required for the opening of the NSR are fully prepared for application. No urgent drawing up of a large-scale or radical program of research and development is required. Improvement in performance and safety of ships, in keeping with the profitability requirements of the global market, will clearly be an issue of paramount importance for the foreseeable future. Subject to changes in national and international maritime regulations, optimum ship design depends greatly on international trends in energy and shipping markets. Despite the maturity of the marine technology applied in NSR shipping, therefore, further research and development of related technologies cannot be neglected.

Surface transportation is predicated on the shipment of large volumes to minimize unit cost. Assuming no upper limit in the demand for a commodity and no problems with safety in navigation, the larger the capacity of the vessel is, the greater its profitability. In the NSR, ship design is limited by the shallowness of the coastal Arctic seas and the size of the escorting icebreakers. Another barrier is the concern that larger ships incur the risk of greater accidents causing pollution of the Arctic. Leaving aside the issue of expected shipping volumes in the NSR, however, it is undeniable that the capacity of currently available vessels in the NSR cannot satisfy the demands for profitability in the international shipping market. When scenarios for seasonal NSR operation are examined, taking into account the operational risks, the need for environmental protection, the size of escorting icebreakers and the problems of handling convoys in escort mode, practical solutions should urgently be found, satisfying the requirements for safety and profitability in NSR operations.

(1) Ship structure, etc.

Ships traveling Arctic seas must above all satisfy a certain level of icebreaking capability and demonstrate safe ship design, with tolerable reliability of the hull, rudder and propellers against expected ice loads. Further study is needed to estimate accurately the interactions between ice and propeller in each mode of operation, but the basic engineering issues involving the design of hull and propulsion system are well on the way to a practical solution.

A unique aspect of NSR navigation is the need for vessels to possess the necessary tugging and towing apparatus for icebreaker support. The best approach would seem to be to draw on Russia's wealth of experience in this field, by studying approaches based on the equipment currently in general use in Russian vessels.

To reduce the cost of ships and boost profitability of navigation, practical and applied research will have to be directed toward matters such as heating and insulation of cargo holds, on-deck water processing, deicing and night vision device. For example, urethane is an excellent insulating material, but its use is restricted due to the ban on CFCs. Future shipbuilding should rely greatly on materials and designs that take into account the entire life cycle of the ship, including repair, renovation and scrapping.

As the results of the operation simulation for NSR shipping demonstrated, much work remains to be done to bridge the gap in competitiveness between the NSR and conventional routes. In terms of both technology and the regulatory framework, measures have to be found to reduce the disparity in construction cost and payload between conventional and NSR ships.

6. Issues to be Resolved for NSR Operation

(2) Engines

Thanks to the development of technologies to boost the output of the main engines of ships, no major problems involving engines remain with respect to NSR shipping. However, because engine failure is a much more serious threat in Arctic seas than in traditional sea routes in open waters, special measures may be needed in terms of inspection and maintenance and in the construction of the engine itself. Also, to prevent or eliminate the emission of atmospheric pollutants from the engine, research in technology for the treatment and management of exhaust gas, such as novel types of exhaust gas denitrizers and desulfurizers, will be needed as the final regulations become clear.

(3) Outfitting and nautical instruments

Ships that navigate the NSR require several additional equipment for use in communications and reception of satellite data in the Arctic environment. The best system will depend on the NSR navigational support systems adopted in the future, which will depend in turn on the type of ship and the frequency of navigation. Preferably the systems for resisting cold and ice accretion will be designed for easy and low-cost maintenance.

(4) Software

Algorithms should be developed for optimum routing in ice-covered waters, with proper mapping of the routes on the basis of real time satellite information.

To improve safety of navigation in drift and pack ice, several outstanding technical issues will have to be resolved. These include monitoring and warning systems for ice loading and related algorithms for automatic steering systems to reduce the risk of damage.

(5) Icebreaker support

The competent authorities in Russia are currently in the process of deciding how to provide icebreaker support in the future, based on their extensive experience in navigation in the region. This support must be framed in terms of the present and future state of international shipping, and should be receptive to the wishes of the global shipping community.

In a step toward harmonization of the regulations of the classification societies regarding icebreakers and icebreaking or ice-strengthened vessels, in November 1989 the USSR and Canada signed an "Agreement Between the Government of Canada and the Government of the Union of Soviet Socialist Republics on Cooperation in the Arctic and the North." It is hoped that this agreement will soon bring an immediate end to the current IMO-based efforts toward harmonization, paving the way for simpler requirements for ship structure and performance and more streamlined inspection/certification procedures.

If the specifications for ships plying the NSR as requested by Russia are not consistent with those required by the IMO and the international insurance industry, the seriously handicapped NSR will never take its place as a viable shipping route. Regulations and recommendations must not ignore the need for shipping firms to be profitable and competitive in the global shipping market. Although Russia is still far removed from becoming a mature, market-oriented economy, it appears likely to revise its current regulations along the lines of the international regulations in the near future, as the global shipping community strives to harmonize the ice class rules of classification societies, including Russia's.

In the near-to-medium term, the NSR, as an international sea lane, clearly demands the renovation and introduction of a modern fleet of icebreakers, with wider hulls, greater capacity and low-cost operation and

maintenance. Since the fulfillment of this wish hangs on the strength of Russian finances, an upturn in Russia's economy is strongly to be desired.

6.2 Operation System

In attempting to render NSR operation practical, many problems are confronted, some of whose solutions are maddeningly elusive. For instance, the Russian escort fee structure is badly distorted, where the escort fee and the NSR shipping frequency and/or volume have an inverse relationship: As the number of requests for support increases, the costs associated with providing the support decrease. The recently privatized Russian shipping companies, which entered into the business of navigating the harsh seafaring environment of the NSR with little preliminary groundwork, may wish to continue with the status quo for a while longer and leave costly technological advances for another time. However, the low levels of NSR shipping, as is generally supposed at the beginning at least, render untenable the expense of maintaining the current fleet of icebreakers. If the NSR administration balances the expenses of the support system against the income from escorted vessels escort fee, the NSR will surely lose its commercial viability. If the opening of the NSR to international shipping was promulgated as Russian public policy, unless some framework were adopted officially for assigning costs and providing financial support through taxation, the NSR cannot open the gate to becoming a internationally competitive sea lane. However, the maritime policies of the Russian government are vulnerable to condemnation as unfair in the international practice and might raise accusations that the arrangement is a violation of GATT.

Another urgent issue is the paucity of infrastructure for such tasks as coastal navigational support, rescue operations and other emergency actions. Some guarantees from the Russian government must be obtained to offset the risk caused by this unfavorable infrastructure compared with those in the conventional shipping routes. Presently sufficient work is lacking on specific scenarios to determine what sort of infrastructure should be provided where. Despite the critical condition of the NSR infrastructure, none of the shipping companies is in the habit of thinking of the NSR as an international shipping route and conducting systematic and purposeful examinations to determine the kind of investments necessary to render shipping viable.

If foreign investment is vital in Russia's NSR operation systems, the benefits and risks of the investment should be assessable. In other words, the investment criterion proposal and outlines of the investment credit, life cycles, investor yield, and investment subsidies and tax credits earmarked specifically for NSR operation should be clearly presented to the international market.

As for satellite information services for prediction of ice conditions, the best service system largely depends on the information users want and how they intend to use it. Although it is too early to establish what this system will look like, an outline of the contents of an NSR information service, or at least its prospects, should be offered to the market. If this action is not taken, few companies would evaluate the NSR as a competitive international shipping route.

6.3 Economic, Social and Political Systems for the NSR

6.3.1 The Economy

(1) The Energy Sector and the Economy

The energy market today is on shaky ground, creating immense repercussions for other industries and economies in the world, and in the Russian economy as well. Russia's vast store of energy resources, and the export of these resources to foreign markets, is often touted as the key to lifting the country out of its present economic turmoil. Yet foreign investors must be sensitive to the widespread public opinion that foreigners are

6. Issues to be Resolved for NSR Operation

depleting Russia's resources. When developing resources in Russia, the necessary laws, administrative organization and social will must be established to avoid isolating Russia in the global market and ensuring that such investment is a good deal for the people of Russia. During the Soviet era, the Ministry of Gas Industry controlled all aspects of the development, transportation, supply and export of oil and gas. This sprawling apparatus was privatized en masse as Gazprom, whose first president was former Prime Minister Viktor Chernomyrdin. If the 20th century belonged to oil, Gazprom reasoned, the 21st century would belong to natural gas. Informed by this perspective, Gazprom set to work on a steady stream of ambitious development projects to supply the demand for natural gas in Europe. Today Gazprom boasts operations in 25 foreign countries worldwide as well as at home in Russia. The company employs 400,000 people and operates a total of 145,000km of gas pipelines, forming a powerful state-within-a-state in Russia. Gazprom's largest domestic gas line under development is the Yamar-Europe Plan, a new route consisting of a large-gauge, double pipeline from the Yamar peninsula to the German capital of Berlin, via the Belarus and Poland pipelines. This vast pipeline spanning 4,500km will cost a total US\$40 billion to build. When completed in 2001, the new route is expected to deliver 65 billion cubic meters of natural gas to customers in Europe. Even before this project reaches completion, Russia supplies Western Europe with some 133 billion cubic meters of gas, satisfying one third of the region's demand. All of this lucrative business is controlled by Gazprom.

Gazprom's overseas strategy extends to the Asia-Pacific region as well. In 1998 the company formed an affiliate called East Gazprom to handle all operations in Asia and the Pacific. East Gazprom is extremely interested in building a gas pipeline from Western Siberia to the East and developing new gas fields in eastern Siberia and the Far East. Once frustrated by obstacles to fundraising caused by continuing American apprehension about trade with Iran, Gazprom is now so large and powerful that it no longer need fear the United States.

In the depressed Russian economy, Gazprom's ready access to hard currency as well as its sheer size make it a unique organization in Russia. How this massive presence will affect the future political landscape of Russia is hard to judge.

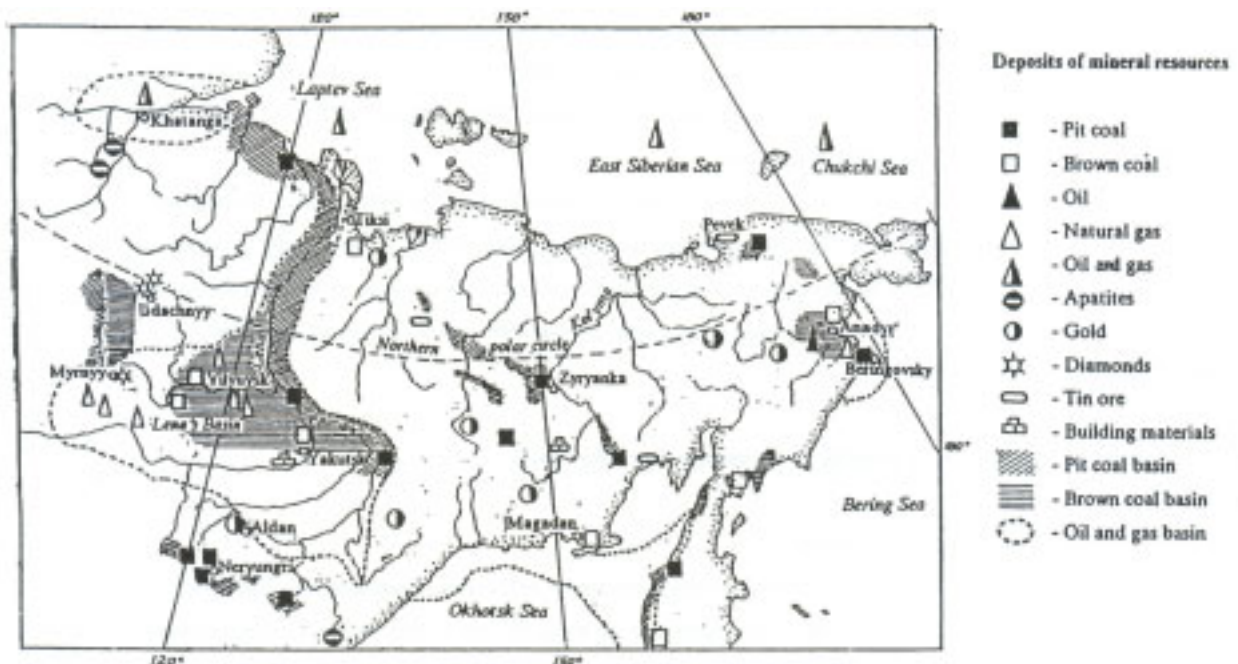

Resources in the NSR region (Ostreg, ed., 1999)

Unlike the gas industry, the oil industry in Russia is fairly fragmented. The wave of privatization that began in 1992 spawned a long list of oil companies large and small. Some of the larger firms are Lukoil, Yukos, Shidanko, Surgutneftegaz and Sivneft. Beginning in 1995, the Russian government began to sell its shares in major petroleum companies to address budget shortfalls. These events quickly sapped the government's influence on the oil industry, and oil companies began linking up with banks to form new industrial and financial groups. Although nowhere as powerful as Gazprom, internationally many are nonetheless known as "giant companies." In 1997, the Petroleum Intelligence Weekly listed several Russian oil companies in their global top 50.

Boasting the greatest productive capacity of Russia's oil companies is Lukoil. In 1996 Lukoil was ranked 14th in the world, with crude-oil output of 51 million metric tons. In terms of crude-oil reserves, Lukoil ranks 11th worldwide. Along with the gas industry, resource-rich Russia's oil industry puts the country in a position of considerable influence over the world economy. The development of resources may hopefully provide the right scenario for the opening of the NSR.

The example of Gazprom shows that a profitable company, or at least one with a solid industrial base, can attract plenty of investment from overseas. On the other hand, unreliable information, unstable governments and incessantly shifting regulatory frameworks conspire to drive foreign investors away. In either case, without a doubt a clear assessment of trends in the energy business in Russia is important in grasping what the future holds for the NSR.

(2) Marine-fishery resources

Russia is keen to export marine resources from the Arctic, but the extent of development of these resources is unclear. The region is rich in the kinds of seafood favored by Asian peoples. Possibility of considerable amount of catch exceeding the personal consumption level of local indigenous peoples and its impact assessment on the global ecosystem will be a very interesting subject of further inquiry with circumspection. In particular, in the Sea of Okhotsk in the Far East, reckless and haphazard fishing is depleting the marine resources of this region at an alarming rate, raising the danger of extinction of many species.

Japan's most important import from Russia is seafood. Every year Japan consumes over US\$1 billion of Russian seafood, accounting for close to 30% of all imports from that country. Crab, shrimp, roe and walleye are prominent. Unfortunately this rather excessive trade will not be desirable from the point of view of the environment, and should be tackled in meetings between the two countries' representatives at an early date. Here it must be borne in mind that a wide discrepancy exists in the imports and exports between Japan and Russia.

(3) Forest resources

Forest products are a major source of export revenue for Russia and Southeast Asia alike. Russia's main export in this field is pine logs. Although in 1997 Japan's lumber imports from Russia were second only to those from the United States, in subsequent years Russia's share of the Japanese market has declined. Whereas the forests of Southeast Asia and North America are close to exhaustion, the Russian lumber business undoubtedly has tremendous potential for export of forest products to Japan. At the same time, the destructive potential to the environment of the northern hemisphere is considerable. Every year forest fires devastate vast expanses of the Siberian taiga, polluting the air with huge releases of carbon dioxide, possibly causing severe damage to Siberia's permafrost. For the preservation of the environment as well as this

6. Issues to be Resolved for NSR Operation

precious resource, reckless deforestation must be avoided in favor of responsible, planned tree harvesting and the implementation of a careful reforestation program.

(4) Mineral resources

Recent hopes have been pinned on imports from Russia to Japan of aluminum and its alloys, as well as nickel. However, the Russian aluminum metallurgy industry had been developed through the tolling system by traders, mostly non-Russian, and the export of raw materials from Russia is not carried out directly but is handled by Western trading companies. (Quite recently President Putin abolished the tolling system. The new status of the Russian metallurgy industry should therefore be carefully assessed.)

(5) Distribution system

Possible rivals to the shipping of goods through the NSR are air freight and the Trans-Siberian Railway. Hauling of trailers by road is likely to be uneconomical because of the vast distances involved and the poor state of Russia's roads. More worthy of closer study are the creation of a so-called land bridge and the use of blended transportation systems. INSRP has not yet paid sufficient attention to these options, and it is worthwhile to ask how well equipped the ports are along the NSR for handling parcel delivery to the final destination. From the point of view of environmental preservation, land, sea and air transportation should not be seen as direct competitors to each other, but rather as inter-dependent modes of transportation, all with their own characteristics and their own role to play in a well-organized and efficient transportation system. In the months and years ahead, further rationalization of shipping systems through the adoption of combined shipping systems (including the NSR) must be duly examined. One implication of the possibility of combined systems is that inevitably the NSR must be capable of handling container shipping.

In political terms, no real barriers exist to opening the NSR. Materially, however, if cargo traffic is not sufficient to sustain it, no amount of conformity to proper form or international law will ensure the health of the NSR as a viable trade route, and the NSR is doomed to languish as a strictly domestic shipping channel. The recovery of the Russian economy is therefore an important precondition, and Russia must table a scenario for economic recovery that foreign countries will find credible. In this light it should be noted that the economic data now under examination by INSRP are not necessarily accurate. If imports and exports through third countries are added, the trade flows would be much higher than official figures suggest, which may help to explain the rapid growth of Russia's middle class despite its economic troubles.

In scenarios involving shipment of goods Northern Europe and European Russia (Russia west of the Urals) to the Far East, the flow of goods cannot be expected to be sufficient to justify the standards of infrastructure the NSR will need to satisfy underwriters. It may be that a realistic scenario for NSR shipping consists not of direct shipping between Europe and the Far East but of a concatenation of shorter, local routes. If so, the development of a wide range of natural resources along the NSR of Russia, the world's greatest trove of such resources, should be the long-term guiding principle in the organization of shipping in the NSR. Only a plan for the NSR as a channel for the shipment of resources, organized in tandem with the orderly development of such resources, appears a realistic scenario for the year-round operation of shipping in the NSR.

6.3.2 Society, Politics and Legislation

One of the conditions for a viable NSR is political stability. Truly stable government involves far more than installing an executive with a president as its head. The same is true of the organization of administration,

although some disagreement exists here. A proliferation of political entities competes for authority and jurisdiction in Russia today. Although Russia is by no means unique in this regard, Russia's gravest environmental problems are often due to the neglect caused by the focus on competition for power. If, despite the vicissitudes of the Russian political landscape, a solid and reliable means of environmental administration were to emerge in the near future, foreign investors' interest in Russia could well be rekindled, and investment would begin to flow into Russia once more.

Problems remain with respect to maritime law as well. Russia's practice in terms of the right of innocent passage through straits, navigation of exclusive economic zones and compulsory navigational support are all contentious with respect to international law. However, most of these problems do not originate solely with Russia. They are rooted in customary practice and the clash of egos among great powers. The best path toward resolution of these issues is frank and open discussion and harmonization toward an international consensus, in an appropriate international convention such as the United Nations. In whatever manner the matter is resolved, it is critical that the question of whether Russia's legislations for the NSR conform to international law and customary be determined with due consideration for the principles of the maritime shipping market.

(1) Indigenous peoples

The coast followed by the NSR is peopled with numerous small tribes of indigenous inhabitants.

The Russian presence in Siberia dates back to the 16th century. By the 17th century the Yakut and Tungus peoples had been absorbed into the Russian state. During this period the Russians pushed rapidly into northeast Siberia, ultimately establishing a border with imperial China at the Amur River. Since the influx of Russians into Siberia in the 16th century, the indigenous peoples of Siberia suffered a litany of misfortune.



Indigenous peoples in Siberia (Ostreng, ed., 1999)

6. Issues to be Resolved for NSR Operation

Inhuman treatment at the hands of Imperial Russia was followed by massive colonization from the Russian West after the Bolshevik Revolution, attended by exile and political imprisonment. The violent excesses and mental and physical anguish caused by this ethnic-Russians-first policy had been prolonged in spite of the later policies by the central government's legislative protection for indigenous cultures.

Even as the Russian economy fell into the throes of collapse, Russian migration to Siberia continued apace. Among the most fortunate of the indigenous groups were those like the Yakut, with their own Autonomous Republic, and peoples such as the Nenets, who at least had their own Autonomous States and Autonomous Districts (before 1977 these areas were mere "tribal districts"). Less numerous tribes, however, deemed too few to warrant their own political entities, remain isolated communities and appear doomed to cultural extinction.

The development of natural resources and policies to stimulate local industry had a momentous impact on indigenous peoples. The Dolgan and Nenets Autonomous Districts-two of the most remote areas of Siberia, perched inside the Arctic-suffered from a baleful influence of the industrial city of Norilsk, which was founded as a core town of the non-ferrous metallurgy industry. The vast reindeer pasture adjacent to the city was constantly disrupted by trucks rumbling in and out of Norilsk. Damaged beyond hope of recovery or repair, this fragile plain is now a bleak and lifeless wasteland. The pastoral kolkhoz on the far eastern tip of the reindeer lands, were known as far away as Northern Europe as one of the success stories of indigenous administration. With the urbanization of Norilsk, however, the kolkhoz was nationalized under the bureaucratic state-farm administration, and their livelihood was gradually eliminated. This upheaval ultimately led to extinction of the kolkhoz. Although the fur and fishery operations of the state-farm were profitable enough, thousands of head of reindeer returned to the wild, inflicting grievous impact on the reindeer ecosystem.

With the opportunity to hunt snatched away by the Russians, many indigenous peoples were out of work and live in squalid conditions. The reindeer herding communities were gripped with despair.

If the indigenous communities shrink below a certain level, they will lose their ability to maintain a separate identity-both culturally and by the simple math of population expansion. Meanwhile Russian settlers continue to move into the region, expunging the indigenous cultures through intermarriage. Today, Russia's



Marine life of indigenous peoples (Bruemmer,1993)

authorities face numerous problems as they try to preserve traditional cultures of the indigenous peoples while integrating them into modern society.

The opening of the NSR is bound to be especially disruptive to those indigenous peoples who make a living by fishing. As ships continue to pass through coastal waters, their economic influence will simultaneously stimulate industry in remote places, as facilities for extracting and shipping mineral resources are erected. This activity might inevitably disturb the traditional ways of life of indigenous peoples in these regions.

(2) Taxation and tariff structure

Russia's tax system and methods of tax collection and the people's consciousness and attitudes toward taxes are beyond the comprehension of Western observers. The imposition of taxes and tariffs, including taxes and tariffs on foreign investment and foreign assets, has been extremely fluid, even arbitrary.

Russia's policy of environmental protection in the NSR includes protective legislation in the form of environmental taxes, in accordance with current global trends. The legislation reflects the theoretical influences of the "precautionary principle," espoused in the 5th Environmental Action Plan of the EU's Joint Policy on the Economy (1993), "polluter pays principle," and the "partnership principle." Persons operating in the NSR are expected to have a sort of compulsory insurance to cover third party liability arising out of environmental pollution. In practice, however, the way in which damages for compensation of large-scale pollution incidents are paid is unclear, partly because the evaluation of environmental value and valuation methods are incomplete. Current socioeconomic data on Russia are of little use in forecasting the viability of the NSR, since shipping volumes ultimately depend directly on the state of the economy. Favorable political judgments and offers of financial incentives to lure cargo transports to the NSR, even when carried out, are usually short-term in effect. No single factor will be more pivotal to the future of NSR shipping than a recovery in the Russian economy. In any event, investment by both shipping companies and operators will be needed, and an accurate assessment of economic trends in Russia is essential to focus NSR investment appropriately. Since energy and mineral resources are the most likely candidates for cargo in NSR shipping, trends in resource development rights and legislation regarding the inflow of foreign capital for such development will be watched closely. Other important factors include increase/decrease in the Russian population in the autonomous states and autonomous districts along the NSR coast, as these trends will play a role in the development of infrastructure and modes of transportation; and changes among the indigenous inhabitants in the attitudes toward development of this nature.

Russia's legal framework, administrative agencies, tax system, environmental protection policies and tariffs are constantly being overturned. Fortunately, though the short-term application of laws affecting the NSR is buffeted by endlessly shifting political winds, the long-term outlook is overwhelmingly positive. This is why any discussion of the legal situation in Russia that is fixated on the status quo of the moment is likely to lead to erroneous conclusions.

One feature of the Russian political and legal landscape that must be monitored closely is public and government opinion in the patchwork of autonomous states [and other local governments] along the NSR coast. These local governments are generally strapped for funding, and opinion on development is divided. Some local authorities have specific expectations for the opening of the NSR and the effects it will bring. Others are determined rather to defend the traditional ways of life of indigenous peoples and see no clear, immediate benefits from NSR shipping. Where powers is rapidly devolved from the center to local

6. Issues to be Resolved for NSR Operation

governments, boosters of the NSR project will find themselves involved in seeking consensus among an assortment of regional and local authorities, which might create a convoluted and time-consuming negotiation process.

6.4 Insurance

In the view of the insurance industry, virtually none of Russia's administrative institutions or official plans inspire any confidence whatever. This state of affairs makes any kind of venture in Russia hard to insure, and any business plan involving Russia's NSR will be subject to close scrutiny and rigorous examination.

Russian government statistics and information often suffer from a lack of transparency. Although results on navigation of the NSR and adjacent seas stand up to rigorous statistical scrutiny, glasnost is still insufficient in terms of damage and accident data, preventing the reliable design of ships based on hazard estimates and risk analysis. NSR shipping results are only available for Russian vessels, which had been usually traveling on some mission of national interest. Even if all of these data are provided, no examination or analysis can be carried out on the numbers of Western-owned ships in the NSR or their navigational experience. This lack of meaningful statistics undermines the job of underwriters, who form the backbone of the insurance system. Even if the sufficient data were available, the NSR must compete for insurance with other, conventional shipping routes. In the absence of sufficient data, insurance premiums may be set as a multiple of premiums on conventional seaways. This approach makes it difficult to establish the NSR as a competitive sea lane. To prove the commercial viability of the route, icebreaker fees and all indirect NSR shipping expenses have to be calculated with great precision, as the results of the simulation project made clear.

INSROP is also short on data that can be used by the insurance system for examination of individual cases. With so little data on which to base a decision, INSROP insurance researchers were forced to submit their reports containing more questions than answers.

For conventional shipping, insurance is indispensable. Normally, shipping companies submit to insurers the various documents they require. After presenting the required data to the insurers, Russian government and authorities should establish the related infrastructure, navigational support systems, related legislation and tariff systems, respecting the wishes of the insurance industry.

Given the organization of the insurance industry and how it works, it seems clear that the most effective way of evaluating the future of insurance for NSR shipping is to perform experimental voyages on the NSR with non-Russian ships.

6.5 Natural and Biological Environment

(1) Natural environment

Thanks to INSROP's efforts, a vast quantity of Russian data is now published, including a great deal of observational data in the Arctic environment. At the very least, this information has deepened understanding of natural conditions in the vicinity of the NSR. The drawback, however, is that Russian observation technology was to some extent outdated, and data at particular locations or in a continuous time series are almost totally lacking. In the eastern half of the NSR especially, because of the forbidding natural conditions, data (especially winter data) are scarce indeed.

If one looks at the NSR as a summer shipping route only, this shortage of winter data is not fatal, at least in the first stages of inquiry. It becomes problematic when research reaches the phase of asking how long the summer shipping season can be extended. Although satellite remote sensing data are also available, current

problems of resolution versus coverage persist as mentioned earlier, and these data, at least from an academic point of view are not appreciably effective in the assessment and measurement of phenomena dependent on the vertical structure of the ocean. At this point NSR seafarers cannot reliably obtain sufficient data to select an optimum route. The near future for remote sensing technology looks bright. Since this source of data should be calibrated and validated by sea-truth data, it is hoped that international agreement can be reached to ensure that these measurements are diligently carried out in international frameworks. The results of these observations will be useful not only for NSR shipping, but for oceanographical researches and studies in preservation of the earth environment on a global scale as well.

GIS is another technology with emerging promise. Although presently GIS relies on past statistical data, GIS in future should grow up to a real dynamic atlas, on which meteorological and ice data in real time or in next-to-real time could easily be accessed, offering accurate and reliable forecasting and a variety of information for effective decision-making.

(2) Biological environment

The ecosystem of marine life in the Arctic Ocean is one of the most badly neglected areas of surveying and research. Vast stretches of ocean await observation and surveying. Because of the tough natural environment in these areas, surveying is extremely expensive and time-consuming, making survey work in these areas highly inefficient.

Surveys of ecosystems, including food chains, involve a large time component. They must include both intensive (local) and extensive study in both time and space and create organic links among these various types of data. Unfortunately research on such an ambitious scale is beyond the capability of INSROP. To save time and cost, INSROP carefully selected certain species that can serve as indices for their ecosystem, then studied the impact on those species of all aspects of NSR shipping under various restrictions, relying on documentary evidence regarding noise, air pollution and marine pollution. The implications of this research for NSR shipping were enormous. If NSR shipping were found to have a strong impact on Arctic ecosystems, such shipping would have to be subjected to numerous restrictions. In some cases new sanctuaries would have to be added to existing ones; in others shipping would have to be prohibited entirely. Fortunately, the results of INSROP's survey supported the conclusion that NSR shipping, including noise, had almost no effect on ecosystems. In many cases, however, more long-term study is needed, to determine the effects of such factors as trace amounts of pollution from passing ships or the effect of shipping on breeding patterns. Further extensive studies are vital to confirm the environmental safety of NSR operation.

The INSROP environmental study did not have time to address issues of the environmental value of the NSR, using valuation methods such as revealed preference or stated preference. Problems of value can be assessed in terms of compensation payable in the event of damage to the biological environment or in terms of the impact of such damage on the insurance premiums for NSR vessels. These issues of assessment of value will have to be addressed in the near future, whether by the Russian government or through international collaboration.

Data on ecosystems, including population figures for indigenous peoples and natural environmental data, were compiled in the INSROP GIS. INSROP GIS will be expected to play a valuable role in much wider fields in the near future.

The natural conditions of the Arctic Ocean are undergoing profound year-on-year changes. Assuming that the ships that ply its waters satisfy the stipulated specifications for NSR vessels, it should take at least several decades of monitoring to determine the effect of the opening of the NSR on the natural environment. On the

6. Issues to be Resolved for NSR Operation



basis of the frequency of NSR operations expected in the near future, it is at least clear that the atmospheric pollution caused by exhaust gas and contaminants from marine engines cannot be thicker than the pollution transported to the Arctic by the global circulation of the atmosphere; they are therefore indistinguishable from each other. Probably the pollution by the operation of ships can only be evaluated only in limited areas, such as the NSR ports.

An urgent priority in evaluating impact on ecosystems is to form the necessary databases to carry out impact assessment. Even aside from the NSR project, such databases are an indispensable part of any system for monitoring global ecosystems. Given the difficulty of performing academic research in the Arctic, some monitoring work by commercial vessels in service would be welcome.

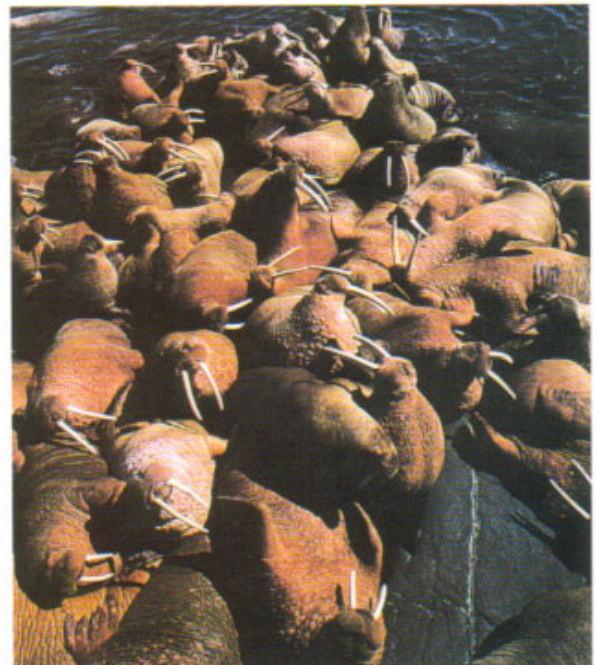

Marine mammals in the vicinity of the NSR
(walrus) (Stonehouse, 1990)

6.6 Concluding Remarks

INSROP's overall conclusion in its study of the feasibility of NSR shipping is that the majority of the problems lie squarely with Russia. These obstacles run from legal issues to questions of taxation and tariffs. Leaving infrastructure issues to one side, many of the problems in bringing NSR shipping to fruition could be solved by modifying the current systems and revising policies. Many of these policies might be underpinned by a misguided protectionism that fears an invasion of foreign capital and the rapine of Russia's economic resources. It will be suggested that Russia will discard these outdated notions and realize that its national interest lies in joining the global market and the international community, while safeguarding its proud role as a great power in both natural resources and culture. When this happens, many of the problems now obstructing commercial NSR shipping will solve themselves.

7. Perspective on the NSR

In the 17th century, Vasco da Gama opened up the southern trade route around the Cape of Good Hope, Russia was making a similar effort to open a northern route as it consolidated its grip on most of today's NSR. As Russia's control of Siberia and the northern coast grew stronger, a succession of rulers from Peter the Great onward strove in one form or another to open up a traditional northeast passage, in the name of the national interest. Given this historical background, the NSR has long been recognized as a Russian territorial route. Secretary Gorbachev's declaration of the NSR as an international commercial shipping route and the work of INSROP and other organizations were all no more than the first step in establishing a commercial route through the Arctic Ocean. History teaches that the only way to build such a route is to accumulate a solid track record of successful commercial shipping.

Once the route is opened, it will have to be fed and sustained. The development and export of natural resources and the development of coastal communities are an essential part of this process, as the history of other commercial routes repeatedly demonstrates. Once the economic viability of NSR shipping is established, the route's continued success will depend on how well the NSR can appeal to the international shipping market. Also critical to success is the rapid recovery of the Russian economy, or at least some clear signs that an upturn is on its way, including indications of inflow of foreign capital.

In 1997 Russia joined the ranks of the democratic world, casting off its previous system of rule by appointed regional leaders in favor of direct election by the citizens. This momentous event opened the path to the empowerment of regions along the NSR, as the first step toward devolution of authority to the regions. The future balance of power between the center and the regions in Russia is now very much an open question, and the future of the NSR depends critically on Russia's ability to sustain itself as a federal state. Today the chain of command between the center and the regions is far from clear, and although the constitution provides for equality among the various parties the practical division of powers and responsibilities is vague. This state of affairs suggests that the process of reaching agreement on the exact powers and interests of each level of government, as well as authority over compensation and the like, will not be a simple one. (Recently President Putin has decided to revive the old systems, in hopes of reestablishing the glory of a great and powerful Russia.)

Developments in the regions may well hold the key to the success of the NSR. Events in Krasnoyarsk deserve close inspection, as this resource-rich region is beset by transportation problems because of its remote central Russian location. Similarly, as Sakhalin develops its oil and gas fields, it can be expected to stimulate latent demand for the opening of the NSR from its far eastern end. As significant as these movements may be, still more important is a production-sharing law passed by the Duma in 1995 and effective as of the following year. Supported by this law, Russia is beginning to invite foreign investment in the development of its energy and mineral resources by the PS process, ceasing disposal by sale to foreign markets. Although this trend only indirectly affects the NSR, its implications are momentous. Rather than arrogating absolute control over resources as heretofore, the Russian government now permits the development of its resources according to the demands of the global market. Of course, the Russian government still dictates what conditions must be satisfied when entering into long-term production-sharing projects such as resource development ventures. The consistent application of this and other laws in Russia rests on the establishment of a stable socioeconomic base, and since this remains a distant prospect, it is probably too soon to be optimistic about the future of production sharing. For this reason the success or any slight failure of the Sakhalin project will be closely watched.

7. Perspective on the NSR

The other member countries of the Commonwealth of Independent States (CIS; the club of former republics of the USSR, minus the Baltic states) are heavily dependent on Russia for their energy resources, and economically in general. The chaos in Russia's economy touched off an economic crisis in the CIS. Despite their acute predicament, the republics of Russia's "near abroad" are trying to wean themselves from this position of dependency. Also, although still in the minority, opposition to Russian political and economic support is slowly growing. This trend towards a more distant relationship with Russia has both positive and negative repercussions for the NSR, and will continue to attract careful observation.

The opening of any trade route occurs because the shipping industry needs it and finds it useful. However much Russia and other interested countries may wish to open the NSR on grounds of logic or national policy, they cannot do the job on their own. The NSR is the first proposed alternative to the Suez Canal route to find recognition with the global shipping community for its competitiveness in terms of length of voyage, profitability and safety. Amid the ever-changing trends of the shipping industry, the NSR will also have to demonstrate a sufficient degree of flexibility.

No model of the global environment could be complete without an understanding of the phenomena that impinge on the Arctic region. It is apparent that more observation and survey work in the Arctic is needed. Not only will this research provide information useful for the substantial opening of the NSR, but it will also break down the popular apprehension people feel for the severe natural environment of the Arctic, bringing about a greater understanding of the precious value of the Arctic nature and its ecosystems. With enough preparation, care and patience in human activities, further research in the Arctic can prove that this icy region is not as hostile to human society as it first appears.

The International Northern Sea Route Programme (INSROP; see Appendix 1) was a cooperative enterprise planned and executed by Japan, Russia and Norway to clarify the requirements for the opening of the northern sea route (NSR). The motivation of each of the participating countries is as varied as the countries themselves. For Russia, the project holds out the prospect of a boost to the Russian society and economy. The Norwegians are interested primarily in gathering data on the marine environment. Japan seeks access to Russian data pertaining to shipping in this region. To these various ends, each country is pressing forward with its own domestic research program as well as international research efforts.

While it is true that survey work on problems on land in the Arctic has been sparse, research data on the central topic of INSROP, the Arctic Ocean, is today recognized as one of the most comprehensive bodies of scientific knowledge on this subject in the world. Researchers with little interest in the commercial shipping aspects of the Arctic Ocean, including geographers, oceanographers and ethnographers, have acknowledged the immense value of this irreplaceable body of research results. As a coda for the scientific efforts of the 20th century and a prelude to those of the 21st, no body of work could be more appropriate.

Unfortunately these studies did not provide a definitive answer to the question of the feasibility of opening the NSR to international shipping. Given the current state of politics and the economy in Russia, it may seem a foregone conclusion that the answer is no. But if conditions in Russia, which are the key to the NSR question, should improve and stabilize, the results of the INSROP research could quickly be marshaled to provide the fastest, simplest and most appropriate path to the creation of a commercial shipping lane.

Today new shipping routes can be established much faster than in Vasco da Gama's day. It was many years after da Gama circumnavigated the Cape of Good Hope that the path he discovered became a regular trade route.

Opening the NSR to international trade will take diligent study in all relevant fields and unflagging effort.

In Japan, no tradition exists of interest in the "lands to the north." Partly this is a legacy from the isolationism of the Edo era, when Japan deliberately turned its back on the north and indeed the outside world; partly it is a hangover from many years of acrimonious Russo-Japan relations. With slight exaggeration, it might be said that even academic circles preferred the Antarctic to the Arctic, to avoid the unpleasant and troublesome negotiations necessary for academic activities in the Arctic region. It would be a shame if Japan were to carry into the 21st century the sorry legacy of the Second World War. The opening of the NSR marks a historic opportunity for this island nation to contribute to the global community as an integral component of it. For industries such as shipping and fisheries, for diplomacy and for the Japanese national interest, it is time for a radical reappraisal of Japan's basic orientation toward the waters of the north.

7. Perspective on the NSR

8. Postscript

INSROP is a project of unparalleled scope. This international collaborative research effort studied the vast expanse of the NSR and the peripheral seas of the Arctic Ocean, drawing on a wide range of disciplines to generate a highly respected corpus of 167 research papers and other publications of results, as well as international symposiums. At the very least, INSROP has provided a comprehensive and detailed body of research results.

It is still a little disconcerting to see Russia, for so long the very antithesis of capitalism, embracing market principles so keenly, bidding for economic growth and receptive to the will of the people. Nonetheless Russia's conversion to Western ways is far from complete. Until Russia begins to have the same understanding of a free-market economy as Western countries do, the opening of the NSR, which falls almost entirely in Russian territorial waters, will remain an undertaking for another time.

The Arctic Ocean is one of the most closely watched bodies of water on earth. Researchers constantly monitor its processes of circulation and deep-water current generation and the impact of global warming. The Arctic Ocean is also rich in natural resources, and it is only a matter of time before the world becomes dependent on them in various senses.

Once thought of as a limitless sea, the Arctic Ocean is today recognized to have limits that are very real indeed. The people of the 21st century must be aware that we live in a planetary ecosystem with limits, and that the earth's waters and oceans are a precious and irreplaceable part of that system.

Another result of INSROP is the boost it gave to Japan's international scientific cooperation activities. Originally formed as a tripartite partnership of Japan, Norway and Russia, by the time INSROP wrapped up it had benefited from the contributions of 390 scientists from 14 countries worldwide. International collaborative projects like these are two parts international diplomacy and one part private-sector diplomacy; INSROP encouraged people from widely divergent viewpoints to sit down and examine various issues together, bolstering teamwork by recognizing and accepting the differences in perception between them. Despite the pressures of the voyage, the extreme environment and occasional communication breakdown, the team members established relationships of trust, both among themselves and with the crew. The fruits of this "private-sector diplomacy" may well be as valuable as the research results themselves.

INSROP's inquiry into the opening of the NSR has brought an array of questions and issues to light. Clearly the NSR is not ready for immediate use as a commercial sea lane. Further experimental voyages and investigations are needed to confirm the conditions found so far, and the results of existing efforts need to be collated to clarify various scenarios and the obstacles to commercial operation.

To establish the NSR as a permanent and viable commercial sea route, the following conditions must be satisfied.

- 1) Sufficient and dependable hydrographical data of sea routes are available and in use.
- 2) Meteorological and oceanographic data and statistics on the sea route and its periphery are available in real time.
- 3) Both hardware- and software-based navigational support systems are established.
- 4) Emergency refuge and rescue support systems are established.
- 5) Ships are designed and constructed to assure safe navigation in the seas expected to be navigated.
- 6) Appropriate navigational methods are established for the seas expected to be navigated.
- 7) Ports along the NSR are properly outfitted to serve as international ports.

8. Postscript

8) Environmental impact assessments are carried out with respect to navigation.

9) The prevailing legal, tax and tariff frameworks satisfy the conditions for profitable and economical shipping.

10) The NSR satisfies economic evaluations of its appropriateness for international distribution operations.

One further condition must be added to ensure the stable development of the route:

11) Appropriate development scenarios are in place to spur growth in undeveloped areas along the NSR.

Vasco da Gama set sail from his native Portugal to open a trade route through the Indian Ocean in July 1497. After a 10-month voyage through vast, uncharted seas, da Gama opened a trade route that brought convulsive changes to the nations of Africa and Asia for over 500 years. Today, half a millennium after da Gama's voyage, we can only speculate on how the opening of the NSR will transform Russia and the other countries along this route.

Reference Materials

- Uemura, N., 1977, All the way to the North Pole, Bunshun Bunko (Japanese)
- Environmental Section, Shipping Policy Bureau, Ministry of Transportation, ed., Treaty on the prevention of marine pollution (Japanese)
- Ohoshima, K., 1999, The MARPOL 73/78 protocols, Journal of the Kansai Society of Naval Architects, Japan, No. 44, pp12-15 (Japanese)
- Ono, N., 1995, Review of oceanographic and atmospheric research in the Arctic, Sokkojiho, 62.1, pp33-55 (Japanese)
- Research Panel for Maritime Law, ed., 1997, A Guide to the basic maritime law, National Government Information Center (Japanese)
- Kajita, M., 1999, The SOLAS Conventions, Journal of the Kansai Society of Naval Architects No.44, pp7-11 (Japanese)
- Kishi, S., et al., 1999 (Jan), Ice-transiting vessels, "RAN" (Kansai Society of Naval Architects), No.42
- Kinoshita, S., ed., 1988, Snow and Ice, Gihodo (Japanese)
- Kuribayashi, T., 1999, Modern International Law, Keio University Press (Japanese)
- Oguchi, T., ed., 1989, Handbook of Scientific Chronology, Two Poles, Maruzen
- Ship & Ocean Foundation, 1994 (Mar), Annual report of the research and development programme of the Northern Sea Route, (A study on an optimum NSR cargo vessel) (Japanese)
- Ship & Ocean Foundation, 1995 (Mar), Annual report of the research and development programme of the Northern Sea Route, (A study on an optimum NSR cargo vessel) (Japanese)
- Ship & Ocean Foundation, 1996 (Mar), Annual report of the research and development programme of the Northern Sea Route, (A study on an optimum NSR cargo vessel) (Japanese)
- Ship & Ocean Foundation, 1996 (Mar), Annual report of the research and development programme of the Northern Sea Route, (Experimental voyage through the Northern Sea Route) (Japanese)
- Ship & Ocean Foundation, 1996 (Mar), Annual report of the research and development programme of the Northern Sea Route, (Data file on measurements on the experimental voyage through the NSR) (Japanese)
- Ship & Ocean Foundation, 1998 (Mar), Annual report of the research and development programme of the Northern Sea Route, (Japanese)
- Ship & Ocean Foundation, 1999 (Mar), Annual report of the research and development programme of the Northern Sea Route, (Japanese)
- Ship & Ocean Foundation, 1999 (Mar.), INSROP GIS (Geographical information system for the International Northern Sea Route) (Japanese)
- Nippon Kaiji Kyokai, 1989 (III), Regulations for steel ships and summary of inspection, volume C, A note on the partial revision, part III, Ice-strengthened structures, Journal of the Nippon Kaiji Kyokai, No. 208, pp. 194-212 (Japanese)
- Aagaard, K., et al., 1983, On the halocline of the Arctic Ocean, Deep Sea Res., 28A, pp529-545.
- Aagaard, K., et al., 1985, Thermohaline circulation in the Arctic Mediterranean Sea, J. Geophys. Res., 90(C3), pp4833-4846.
- Aagaard, K., et al., 1989, The role of sea ice and other fresh water in the Arctic circulation, J. Geophys. Res., 94(C10), pp14485-14498.

Reference Materials

- Administration of the Northern Sea Route, 1996, Guide to navigating through the Northern Sea Route, No.4151B.
- ASPPR, 1997, Arctic Ice Regime Shipping Standards.
- Barry, R., 1989, The present climate of the Arctic Ocean and possible past and future states, *The Arctic Seas - climatology, oceanography, geology and biology* (Herman, Y. ed.), pp1-46.
- Carmack, E.C., 1986, Circulation and mixing in ice-covered waters, *The Geophysics of Sea Ice* (Untersteiner, N. ed.), pp641-712.
- Engelhardt, F.R. (ed.), 1985, *Petroleum effects in the Arctic environment*, Elsevier Appli. Sci., pp117-215.
- Fetteerer, F., et al., 1998, Observations of melt ponds on Arctic sea ice, *J. Geophys. Res.*, 103(C11), pp24821-24835.
- Freitas, A., et al., 1978, A new icebreaking concept, *Proceedings of IAHR Symposium on Ice Problems*, part 1, pp293-317.
- GESAMP, 1993, Impact of oil and related chemicals and wastes on the marine environment, IMO/FAO/UNESCO/WMO/WHO/IAEA/UN/UNEP Joint Group of Experts on the Scientific Aspects of Marine Pollution (GESAMP), GESAMP Reports and Studies No.50, IMO London.
- Herman, G.F., 1986, Arctic stratus clouds, *The Geophysics of Sea Ice* (Untersteiner, N. ed.), pp465-488.
- Izumiyama, K., et al., 1996, Ice resistance of three bow forms for the NSR cargo ship, *The Proceedings of INSROP Symposium Tokyo '95*, SHIP AND OCEAN FOUNDATION, pp459-467.
- Johannessen, O., et al., 1992, ERS-1 SAR ice routing of L'Astrolabe through the northeast passage, *The Nansen Technical Report No. 56*, Environmental and Remote Sensing Center.
- Karaminas, L., 1999, Harmonization of Polar Shipping Rules – new prospects for the maritime industry, *Proceedings of the 15th International Conference on Port and Ocean Engineering under Arctic Conditions*, vol.2, pp899-906.
- Kassens, H., et al, 1998, Russian and German scientists explore the Arctic's Laptev Sea and its climate system, *Eos, Trans., AGU* 79, pp317-323.
- Kitagawa, H., 1996, R & D project of a cargo ship for the NSR, *The Proceedings of INSROP Symposium Tokyo '95*, SHIP AND OCEAN FOUNDATION, pp453-457.
- Kowalik, Z., et al., 1994, The Arctic Ocean tides. The polar oceans and their role in sharpening the global environment (Johannessen, O. M., et al., ed.) pp137-158
- Kruglikova, S.B., 1989, Arctic Ocean radiolarians, *The Arctic Seas - climatology, oceanography, geology and biology*, (Herman, Y. ed.), pp461-480.
- Maisson, K., et al., 1995, Inventory on transport patterns and risk estimation of oils carried in the Baltic Sea area, HELCON Report 75 96-1.
- Marine Environment Division, IMO, 1995, *The OPRC Convention in Brief*, OPRC Colloquium'95.
- Matyushenhko, N., 1992, The Northern Sea Route: challenge and reality, international challenges, vol.2 no.1, *The Fridtjof Nansen Institute Journal*, Special Issue on the Northern Sea Route, pp58-63.
- Mulherin, N.D., et al., 1996, Development and results of a Northern Sea Route transit model, U. S. Army Cold Regions Research and Engineering Laboratory Report 95-5.
- NASDA/NASA , 1998, ADEOS Earth View, '98/10.
- Ono, N., 1996, Variability of Arctic sea ice along the Northern Sea Route, *The Proceedings of INSROP Symposium Tokyo '95*, SHIP AND OCEAN FOUNDATION, pp505-508.
- Østreng, W., et al.(ed.), 1999, *The natural and societal challenges of the Northern Sea Route: a reference work*, Kluwer Academic Publishers.

- Parkinson, C.L., 1997, Earth form above, University Science Books.
- Peltier, W.R., 1998, Postglacial variations in the level of the sea: implications for climate dynamics and solid-earth geophysics, *Rev. Geophys.*, 36, pp603-689.
- Pettersson, L., et al., 1999, Satellite radar ice monitoring for ice navigation of the ARCDEV tanker convoy in the Kara Sea, *Proceedings of the 15th International Conference on Port and Ocean Engineering under Arctic Conditions*, vol. 1, pp141-153.
- Polar regions atlas (National Foreign Assessment Center), 1978, Central Intelligence Agency.
- Radionov, V.F., et al., 1997, The snow cover of the Arctic basin, *Appl. Phys. Lab.-Univ. Washington*, TR9701.
- Romanov, I.P., 1994, Ice cover of the Arctic basin, St. Petersburg.
- Romanov, I.P., 1995, Atlas of ice and snow of the Arctic basin and Siberian shelf seas, Backbone Publ. Co.
- Saavala, J., 1999, Suggestions for future NSR shipping based on NSR experience, *Executive Summaries of the Northern Sea Route User Conference*, The Fridtjof Nansen Institute, Oslo, Norway, pp91-94.
- Schwarz, J., 1995, Can the Northern Sea Route be profitable, *The Proceedings of INSROP Symposium Tokyo '95*, SHIP AND OCEAN FOUNDATION.
- Smirnov, V., et al., 1999, The use of satellite information for ice navigation support, *Proceedings of the 15th International Conference on Port and Ocean Engineering under Arctic Conditions*, vol. 1, pp154-165.
- Wergeland, T., 1992, International challenges, *The Fridtjof Nansen Institute Journal*, volume 12 number 1-1992, Special Issue on the Northern Sea Route.
- Yamaguchi, H., 1996, Experimental voyage through Northern Sea Route, *The Proceedings of INSROP Symposium Tokyo '95*, SHIP & OCEAN FOUNDATION.
- Zerefos, C.S., et al., 1997, Variability of UV-B at four stations in Europe, *Geophys. Res. Letters*, 24, pp1363-1366.

Video References

- Ship & Ocean Foundation, 1995 (Aug), *Experimental Voyage through Northern Sea Route : A Report from the Northern Sea* (Approx. 30 minutes)
- Ship & Ocean Foundation, 1995 (Aug), *Ditto;digest version* (approx. 20 minutes)
- 「Experimental Voyage through Northern Sea Route ~ A Report from the Northern Sea ~」(NTSC type, PAL type) August 1 to 28, 1995 (Approx. 30 minutes)

Bibliography

- A.E. Nordenskiöld (translated into Japanese by T. Ogawa), 1988, *Voyage of the Vega* (Part 1, Part 2), Fuji Publishing
- Akitsuki, T., 1999, *History of Japanese exploration and mapping of the north*, Hokkaido University Press (Japanese)
- Aoki, Y., 1998, *Paths through the sea and the meeting of east and west*, World History Libretto 25, Yamakawa Publishing (Japanese)
- Asahi Lecture Series, *Exploration and Adventure* 6, 1972, Asahi Shimbun (History of exploration and surveying of the North and South Poles, scientific survey methods and other related information), NHK

Reference Materials

- Documentary Journalism Bureau, 1989, *The Arctic Circle*, 1, Nippon Hoso Publishing (Japanese)
- Asimov, I., *The end of the earth-the polar regions of the world*, 1975 (Japanese version: Bunka Hoso Press)
- Fridtjof Nansen (translated into Japanese by Sawada, Y.), 1998, *The voyage of the Fram and the crossing of the Arctic Ocean: Farthest North*
- Fridtjof Nansen, 1897, *Farthest North*, Fukuonkan Shoten
- Fukuda, M., ed., 1997, *Polar science and the warnings from global sensors*, Hokkaido University Press
- H.S. Wright, 1914, *The great white north*
- Hiraoka, H., translator, 1935, *The last voyage of the Soviet Arctic exploration vessel Chelyuskin*, Nauka, Translated by Hiraoka
- Kano, I., 1960, *Polar exploration and the North Pole*, Jiji Press
- Kondratov, A. (translated into Japanese by S. Saito), 1991, *Story of the lands of the Arctic Circle*, Chijin Shobo
- Masumoto, S., translator, 1956, *How the mystery of the Arctic ice cap was solved*, Shunshusha
- Okada, H., 1994, *Journal of Northern Culture*, Academia Publishing (Japanese)
- Okada, H., et al., ed., 1992, *Ethnology of the North*, Academia Publishing (Japanese)
- Saka, K., *Present condition and trends in polar oil and gas resource development technology: Development of oil resources and oil reserves*, Dec. 1987-Dec. 1994 (Japanese)

Appendix

Appendix A.....	170
1. INSROP.....	170
2. Chronology of Events in the Opening of the NSR.....	173
3. History of Scientific Research in the Arctic Ocean (excerpts).....	175
4. Sea Ice Terminology	177
5. International symbols for sea-ice conditions ("the egg")	178
Appendix B: Hull Form Development by JANSROP.....	179
1. Development of an icebreaking cargo ship for coastal NSR navigation.....	179
2. Development of Icebreaking Cargo Ship for the NSR Northerly Route.....	189
Appendix C: Supplementary Data on Operation Simulations.....	194
Appendix D.....	209
1. Brief Russia History (after 16th century).....	209
2. Administrative Units in the Russian Federation.....	210
3. CIS States Other Than Russia.....	211
4. Main Governmental Organizations of the Russian Federation (in 1998).....	214
Appendix E: List of INSROP WORKING PAPERS.....	215
Appendix F: Other INSROP Source Data.....	224
1. Charts of the NSR.....	224
2. Guide to Navigating through the Northern Sea Route 1996 (No. 4151B)	226
3. Russian Ice Navigation Practices.....	226
4. Regulations for Navigation on the Seaways of the Northern Sea Route 1991.....	227
5. Natural Resources of Russia along Eastern Half of the Northern Sea Route.....	227
6. Miscellaneous Source Data.....	228
7. Web Sites for the Arctic and Antarctic Research Institute of Russia.....	228
Notes on Contributors.....	230

Please note:

In order to make the English version of this report easier to read, the notation of appendices in the English version (Appendix A, B and C) differs from the notation used in the Japanese version (Appendix A and B).

Appendix A

1. INSROP

(1) Brief history of INSROP

The seeds of the International Northern Sea Route Programme (INSROP) were planted in October 1987, when Secretary Mikhail Gorbachev declared the NSR open to international traffic. The task of interpreting this declaration in terms of specific policies fell to the USSR's (and later Russia's) Ministry of Transportation, which began discussions with Norway's Fridtjof Nansen Institute (FNI) on collaborative efforts in November 1988. After almost a full year's deliberation, in 1990 Russia's Central Marine Research and Design Institute (CNIIMF), located in St. Petersburg, and the FNI in Oslo agreed to conduct a preliminary feasibility study regarding the opening of the NSR. This study, which took a year and a half to complete, concluded that the NSR question warranted the formation of a new research and survey organization to launch a program of full-scale research.

Russia then expressed its sincere wish for Japan to take part as well, as a representative of the eastern economic bloc that would be served by the new route. As a result of ensuing discussions, the research and survey plan that had already been mooted between Russia and Norway was radically revised, and Japan agreed to collaborate as an equal partner with Russia and Norway. Supported by the Nippon Foundation, Japan's Ship & Ocean Foundation (SOF) approved participation in an extensive feasibility study. In 1992 deliberations began on the detailed structure of INSROP, including its research policy, detailed plans, fundraising methods, fiscal year and method of executing research plans. Consensus among SOF, FNI and CNIIMF was reached in April 1993, and the following May the three parties signed an Agreement for Research Cooperation, whereupon the new organization set to work on its first, three-year phase.

The chairman of the Nippon Foundation, Yohei Sasagawa, chaired the executive body of INSROP, the Steering Committee of Sponsors (SCS). This body was responsible for coordinating the various views of the three participating countries to determine the basic policies of the organization. Below the SCS, a Joint Research Committee (JRC) was established to deliberate upon, coordinate and select the actual research content and to propose plans for the execution of research.

In counterpoint to INSROP, the SOF, under the leadership of its chairman, Prof. Yuzuru Fujita assembled a group of professionals to form an NSR development, survey and research committee. This committee's brief was to promote INSROP and to conduct its own, uniquely Japanese survey and research work, to ensure that the results of INSROP's efforts would be gathered and applied as effectively as possible to the unique technological and social needs of Japan.

(2) Overview of INSROP

The first six years of INSROP were divided into two phases. Phase I consisted of the period 1993-1995 and Phase II included the years 1997 and 1998. In 1996, an impartial evaluating committee of outside professionals and specialists was formed; this group examined and appraised the results of Phase I and offered its advice on the necessity of a Phase II plan, basic directions in research and order of precedence of various topics. The Phase II plan was duly deliberated, prepared and executed according to the recommendations of this evaluating committee.

In Phase I, a Joint Research Committee composed of participating committee members from Japan, Norway and Russia examined and decided upon individual research topics for the following four

sub-programs, for assignment to specialists from around the world for further survey and research work.

- * Sub-program I : Natural conditions and ice navigation
- * Sub-program II : Environmental Factors
- * Sub-program III : Trade and commercial shipping aspects of the NSR
- * Sub-program IV : Political, legal and strategic factors

The results of these individual research topics were submitted as discussion papers to FNI, which served as the secretariat for INSROP. Specialists not affiliated with INSROP then deliberated on and evaluated these papers and suggested revisions, either in writing or verbally. With the comments of committee members and the original authors newly incorporated in the documents, these papers were then published as INSROP working papers.

With the ardent support of the Nippon Foundation, the individual research results in Phase I were announced at a symposium in Tokyo in October 1995 called IST '95, "Northern Sea Route: Future and Perspective." International leaders in each field were invited to attend, and the event succeeded in raising the profile of the NSR project.

In August 1996 INSROP conducted an experimental voyage of the NSR with the Kandalaksha, an icebreaking cargo ship owned by the Murmansk Shipping Co. (MSC). This vessel was able to traverse the distance from Yokohama to the Norwegian port of Kirkenes in surprisingly short order without incident. The voyage succeeded in verifying the essential viability of the NSR, provided an opportunity to examine certain problems with NSR navigation and deepened researchers' understanding of the Arctic Ocean.

The plan for INSROP Phase II was executed over the 1997 and 1998 fiscal years, under the supervision of the International Evaluating Committee. During this time the following actions were taken:

- * Supplementation of the activities in Phase I
- * Integration and collation of the results of INSROP activities
- * Upgrading and extension of INSROP GIS

The research results were integrated and collated by three editors, one from each participating country, and published as INSROP working Paper No. 167, "The Challenges of the Northern Sea Route-Interplay between Natural and Societal Factors." A team of 12 writers contributed the following six chapters, organizing the INSROP results according to fields of specialization.

1. Historical and geopolitical context of the Northern Sea Route: Lessons to be considered
2. The natural environment, ice navigation and ship technology
3. Environmental assessment
4. Economy and commercial viability
5. Military, political, legal and human affairs
6. The multiple realities of the NSR: geographical hot and cool spots of navigation

At the very least, INSROP GIS boasts content of an excellence far beyond any similar system, existing or under development. Even so, some critical data are missing. These data should be obtained as quickly as possible through further international collaborative research.

Specialists from within and outside INSROP carried out the NSR operation simulation as a group research effort. Overviews of several designs for NSR vessels were conceived and run through simulations on PCs to assess the economic viability of NSR navigation of each ship design under each of several modes of operation and for each sea and section of sea in the NSR, taking into account factors such as navigational support infrastructure, type of freight and forecasts of freight movement, environmental impact and tariffs.

A total of 390 researchers from 14 countries took part in the INSROP project, generating some 167

Appendix

working papers, including those prepared in Phase II. When international symposiums, academic journals and submissions to academic seminars are included, over 200 theses were written as a direct result of INSROP.

One of Japan's key objectives in taking part in this ambitious project was to encourage the publication of Russia's wealth of data on the NSR region, so that it could be put to use by the international community and give a concrete sense of the actual state of the Arctic Ocean. For Russia and Norway, who have frequent working experience of conditions in the Arctic, priorities were understandably somewhat different. In planning the project it seems to the authors that both Norway and Russia allowed national pride to get in the way of good science at times. One of the greatest achievements of Japan's participation in INSROP may well have been its success in obtaining richer rewards from the research effort by mediating between the viewpoints of these two nations, encouraging them to reaffirm their commitment to the international character of this project and obtaining the permission of the Russians to publish their previously accumulated data.

2. Chronology of Events in the Opening of the NSR

BC Circa 300	Pytheas, Greek seafarer, possibly reaches Iceland
BC c. 190-120	Hipparchus, first to use latitude and longitude
BC c. 112	Opening of Silk Road
AD c. 100	Ptolemy publishes Geography
c. 860	Legendary voyages of St. Brendan and Naddod the Viking to North America
862	Novgorod founded by Rurik the Viking
	Trade network to Black Sea is established
c. 982	Erik the Red banished from Iceland
c. 986	Bjame Herjolfsson discovers lands close to Greenland, possibly North America
c. 1000	Vikings colonize Greenland
1004-13	Thorvald Ericsson attempts to settle in Vinland
c. 1100	Hanseatic League founded
1240-1480	Mongol incursion into Russia
1260-71	Maffio and Niccolo Polo arrive in China
c. 1360	Nicholas of Lynn sails from Norway to Greenland
1440-1505	Ivan III unites Russia
1492	Columbus discovers New World
1498	Vasco da Gama reaches India.
1519-22	Magellan's ship "Victoria" circumnavigates globe
1533	The Moscovy Company founded
1543	Portuguese reach Japan
1553-54	Willoughby and Chancellor search for Northeast Passage via Barents Sea
1556	Stephen Borough sails to entrance of Kara Sea and winters at Archangel
1576-78	Frobisher reaches Frobisher Bay in Baffin Island
1577-80	Drake circumnavigates globe; unsuccessfully Northwest Passage
1578	Cossacks invade Yermak and Siberia
1581-82	Yermak begins Russian conquest of Siberia
1585-87	Davis searches for Northwest Passage
1594-97	Barents discovers Bear Island, Spitsbergen and Novaya Zemlya
1600	Liefde drifts ashore in Bungo (in Japan)
1610-11	Hudson sails to Iceland, Greenland, Hudson Strait and Hudson Bay
1623	Fur hunters reach Lena from Yenisey
1643	Fliis voyages to northern Japan
1648	Semen Dezhnev sails through Bering Strait
1697-1699	Atlasov explores the Kamchatka Peninsula
1711	Kozirevsky conducts second campaign into Chishima.
1725	Bering conducts his first exploration of Kamchatka and reaches Okhotsk.
1733-1743	Russian exploration team conducts the Great Northern Expedition.
1741	Bering and Chirikov reach Alaska
1798	Cook attempts to fund Northwest Passage by sailing through Bering Strait
1779	Clarke and others explore Bering Sea
1804	Kondo Juzo produces "Demarcation Map of Outlying Posts."

Appendix

1808	Mamiya Rinzo produces "Great Map of Karafuto."
1821	Ino Tadaka produces "Complete Map of Coasts of Japan."
1858	Russia annexes north bank of Amur River under Treaty of Aigun
1860	Russia annexes a series of coastal regions under Treaty of Peking.
1874	Weyprecht and Payer discover Franz Josef Land
1875	Treaty between Japan and Russia exchanges Chishima for Sakhalin
1878-80	Nordenskiold successfully crosses Northeast Passage and reaches port at Yokohama
1879	De Long in Jeannette travels overland to New Siberian Islands from Bering Strait
1893	Captain Gunji explores Chishima
1893-96	Nansen in "Fram" sails to Laptev Sea
1898	Icebreaker Yermak is constructed.
1903-1905	Amundsen in "Gja" completes first successful navigation of Northwest Passage
1909	Peary reaches North Pole.
1913	Arctic Ocean Hydrographic Expedition of Russia discovers Novaya Zemlya, etc
1915	Russian admiral Vil'kitskiy traverses Northwest Passage from east to west
1932	Sibiryakov traverses NSR in a single summer. Russia establishes Chief Administration of Northern Sea Route
1942	Soviet battleship crosses NSR.
1972	Icebreaking cargo ship "Indigilka" crosses NSR in winter.
1995	Icebreaking cargo ship "Kandalaksha" conducts test navigation of NSR in summer

3. History of Scientific Research in the Arctic Ocean (excerpts)

1831	Britain: James Ross surveys the North Magnetic Pole (69° 34' N, 94° 54' W).
1878-1880	Sweden: Nordenskiöld surveys the Northeast Passage in the Vega (first voyage through the Northeast Passage to Japan within a two-year period).
1882-1883	First International Polar Year. Surveys of the Arctic are conducted at 13 observation sites.
1893-1896	Norway: Nansen's Fram is carried on drift ice on a trans-Arctic survey.
1932-1933	Second International Polar Year. Soviet Union maintains 22 observation posts in the Arctic Circle.
1932	Soviet Union: Shmidt's steam-powered icebreaker Sibiryakov surveys the Northeast Passage (first single-year crossing of the Northeast Passage to reach Japan).
1932	Soviet Union: Central Bureau of the North Atlantic Route ("Central Bureau") is established with Shmidt as director.
1933	Soviet Union: Shmidt's steam-powered Chelyuskin surveys the Northeast Passage (sinks in the Chukchi Sea).
1934	Polar Laboratory is established within the Central Bureau.
1937-1938	Soviet Union: Papanin Arctic drift-ice station is established (later designated North Pole 1).
1941	Japan: Planned pole-to-pole voyage of the Kaiho Maru fails when the vessel is forced to return to Japan from the Arctic Ocean.
1947-1955	United States: Regular atmospheric observations are conducted in the Arctic, from Alaska to the North Pole (frequency of observations is later increased to once a day).
1950-1951	Soviet Union: Drift-ice station North Pole 2 is launched, led by Somov.
1952	United States: Base is established on ice island T-3 (closed in 1954, reopened in the International Geophysical Year).
1957-1959	International Geophysical Year: Approximately 80 observation points are established in the Arctic. United States' T-3 and Soviet Union's North Pole 6 (on an ice island) and North Pole 7 are in active use. North Pole 7 visits various countries on the western side of the Arctic Ocean and is opened to the public.
1958	United States: Nuclear-powered submarine Nautilus crosses the Arctic Ocean submerged.
1958	Soviet Union: Arctic Laboratory is expanded into the Arctic and Antarctic Laboratory.
1961	United States: Drift-ice observation is carried out on ice island ARLIS-II.
1969-1970	United States: Large icebreaking tanker Manhattan conducts test navigation of the Northwest Passage.
1972-1975	United States and Canada: Arctic International Drift-ice Joint Expedition (AIDJEX)
1972-1981	International Polar Experimental Observation (POLEX)
1987	Soviet Union: North Pole 30 is constructed and named the Vitus Bering.
1987	Soviet Union: In a speech at Murmansk, Secretary Gorbachev pledges international cooperation in the scientific survey of the North Pole.
1988	Soviet Union: North Pole 31 is constructed. The following year its activities are reported by NHK.
1990	Japan: Arctic Circle Environmental Research Center is established within the National Polar Laboratory
1990	International Arctic Science Committee (IASC) is founded.
1991	Soviet Union: North Pole 30 and 31 are decommissioned. Planning of an arctic drift-ice station is completed.
1993-1998	INSROP is conducted.
1995	Japan: Test navigation of the NSR is conducted aboard the Kandalaksha.
1997-1998	Canada, United States: Drift-ice tests are conducted as part of surface-heat observations in

Appendix

	the Arctic Ocean (SHEBA).
1998	United States: International Arctic Research Center (IARC) is established at University of Alaska (Fairbanks).
1998	Japan: Atmospheric observation is conducted by aircraft in the Arctic Circle (by return observation flight from Japan).

4. Sea Ice Terminology

The nomenclature and terminology of ice in the nature varies widely from country to country. Perhaps a dozen glossaries of sea-ice terminology have been published, all different in some respects. In 1956, the International Geophysical Year (IGY), the World Meteorological Organization (WMO) introduced a measure of international consistency in this terminology. The WMO updated its glossary in 1970 and published it in English, French, Russian and Spanish, illustrating the terms with photographs. A Japanese translation of the terms was provided in a 1971 volume called "New WMO Sea Ice Nomenclature" by Yushiro Kuga and Masaomi Akagawa (Seppyo [snow and ice] 33, pp98-105). With subsequent revisions, the glossary was published again in 1990 by the Japan Meteorological Agency as "Oceanological Observation Guidelines (Meteorological Agency Edition)." A list of categories with brief descriptions in Japanese can also be found in the "Dictionary of Snow and Ice" (1990, Kokinshoin).

When the WMO established its glossary of sea-ice terms, ice was primarily observed from the shore, sea or air, and the categories in this volume reflect that bias. In a slight revision (1985, 1989), terminology was added that reflected observation from below the ice, in submarines. As the leading role in sea-ice observation shifted to satellites, much larger ice patterns became observable, requiring the addition and standardization of a raft of new terms. The standard terms for these more newly observed phenomena have not yet been selected. SOF uses its own translation of "Russian - Japanese Dictionary on Sea Ice (SOF, March 2000)," to which the WMO has added categories and definitions. Focusing on the sea-ice categories listed by the WMO, an explanation of certain key terms was provided in the original Japanese text.

For a more detailed explanation of each of these terms, please refer to the terminology of the World Meteorological Organization.

5. International symbols for sea-ice conditions ("the egg")

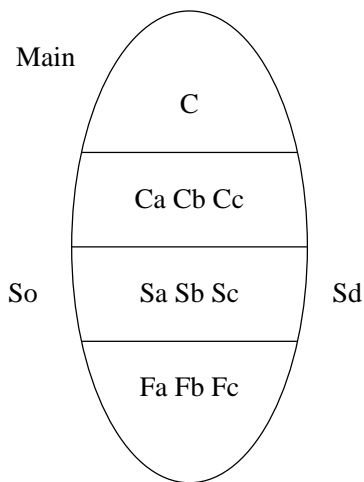

Concentration (C): Total concentration of ice of the entire sea area under consideration

$$C = C_a + C_b + C_c$$

Concentration of ice classified according to thickness (for concentration 1/10 and over)

C_a: concentration of S_a-ice,

C_b: concentration of S_b-ice,

C_c: concentration of S_c-ice

Development

S_a: Thickest ice

S_b: Next thickest ice,

S_c: Third thickest ice

S_o: Development of ice with 1/10 concentration or less but thicker ice than S_a

S_d: If ice of other categories is present, mention the development of that ice.

Supplementary

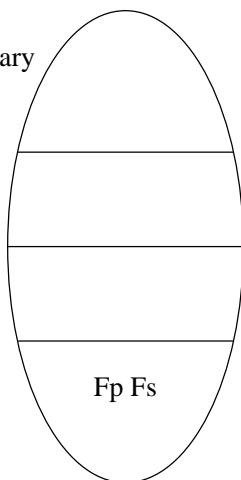

Size of floe (F):

F_a: size of S_a-ice,

F_b: size of S_b-ice,

F_c: size of S_c-ice

F_p, F_s: Sizes of two most predominant types of ice regardless of S

	C	S (development and thickness)	F (forms of floating ice)
0	1/10		Pancake ice (30 ~ 300cm)
1	1/10	New ice	Small ice cake, brash ice (2m)
2	2/10	Nilas and ice rind (10cm)	Ice cake (2 ~ 20m)
3	3/10	Young ice (10 ~ 30cm)	Small floe (20 ~ 100m)
4	4/10	Grey ice (10 ~ 15cm)	Medium floe (100 ~ 500m)
5	5/10	Grey-white ice (15 ~ 30cm)	Big floe (500m ~ 2km)
6	6/10	First-year ice (30cm ~ 2m)	Vast floe (2 ~ 10km)
7	7/10	Thin first-year ice (30 ~ 70cm)	Giant floe (> 10km)
8	8/10	Thin first-year ice I (30 ~ 50cm)	Fast ice, growler, floeberg
9	9/10	Thin first-year ice II (50 ~ 70cm)	Iceberg
9+	9/10 ~ 10/10		
10	10/10		
1 .		Medium first-year ice (70 ~ 120cm)	
4 .		Thick first-year ice (> 120cm)	
7 .		Old ice	
8 .		Second-year ice	
9 .		Multi-year ice	
.		Ice of land origin	
X	Unknown	Unknown	Unknown

Appendix B: Hull Form Development by JANSROP

When INSROP was launched, the SOF established a NSR Research Panel to implement JANSROP. Carried out in parallel with the SOF's support of INSROP, JANSROP was conceived as an NSR research project conducted with the priorities and point of view of Japan. JANSROP performed the following research activities:

- * Research to find the optimum hull form for NSR (FY 1993-1995)
- * Surveys and research on the basic performance required for icebreaking cargo vessels (FY 1997)
- * Research and development of a numerical forecasting system for ice conditions in the NSR

The first of the above projects, research from FY 1993 to FY1995 to find the optimum hull form for NSR, can be further broken down into the following research topics.

- * Model tests in ice and open water of designs for the optimum hull form
- * Analysis of characteristics of propellers in ice-covered waters and of interactions between ice and propellers
- * Research into the interference between floes and waves
- * Analysis of sea ice data in the Arctic

In this section an overview of the data referred to in Chapter 4 is presented, focusing on research concerning the development of icebreaking cargo ships for the NSR. For further details on this research, the Annual Reports of JANSROP by the SOF are available.

This research to develop hull forms for NSR navigation was conducted in two phases, Phase I (FY 1993-1995) and Phase II (FY 1997). In Phase I, hull form development was concentrated on the design of a commercial vessel with a shallow draft, suited to the shallow waters of Russia's coastal seas. Phase II tackled the development of a ship with a deeper draft, intended for use in the deeper waters far from the shore. A crucial aspect of this research was the exploration of ways to expand the limitations on the ship's draft, so that as large a ship as possible could be built; the larger the ship is, the more competitive it becomes in comparison to the conventional Suez Canal route. Also, this research was intended to develop ship designs that could be applied in the operation simulation carried out in parallel at INSROP.

1. Development of an icebreaking cargo ship for coastal NSR navigation

For coastal NSR navigation, the hull form was developed according to the following timetable.

- * Basic design (FY 1993)

Key features of the vessel were determined based on collected data on water depth and safety of ports in the NSR Candidate vessels were then designed on the basis of this data and models were produced for testing.

- * Tank test (FY 1994)

Using the models designed and produced the previous fiscal year, models of each candidate design were tested in ice and open water.

- * Development and testing of new ships (FY 1994, 1995)

Symbols in the Appendix B

B	: Ship width
D	: Ship depth
Fn	: Froude number defined by ship length
L	: Length of ship
R	: Total resistance in ice
V	: Ship speed
g	: Gravitational acceleration
h	: Ice thickness
t	: Thrust deduction coefficient
w	: Wake fraction
p	: Water density

Appendix

The characteristics of each ship type were analyzed according to the results of the above tests and design of the new ships proceeded on that basis. Models of the new ships were also built and tested.

* Overall evaluation (FY 1995)

Overall evaluation was conducted for each ship design, based on the results of the model tests, and the final ship design proposal was determined on the basis of this evaluation. The details and results of this process were as follows.

1.1 Basic Design

In the first phase of research, the basic design was conducted for each of the hypothetical ship types in this research project. To select the ship types and their particulars, the survey work was carried out on the ship's cargo volume and allowance for ship draft due to shallow water depth, features of ports in the NSR and the NSR in general. The results of these examinations formed the basis for the research that followed on the design of a multipurpose cargo ship that could navigate from the port of Murmansk through the NSR to Japan (with the assumption of some inland river navigation). The principal particulars of the ship are summarized in Table B-1. The engine room of the ship was located in the stern. The ship has a double-sided and double-bottomed structure with the ballast tanks at the sides, fore and aft. The main engine output was determined by estimating power based on a prediction formula of ice resistance, to satisfy the stipulated icebreaking capability. A controllable-pitch propeller was designed to be driven directly by a diesel engine. Both conventional and nozzle propeller types were also examined. Following determination of the ship type and its main particulars, design work commenced. Recognizing that the shipbuilding industry of Japan has little experience of constructing icebreaking cargo ships, a systematic study of the ship types and their performance was executed using tank tests and theoretical

Table B-1 Principal particulars of icebreaking cargo ship for coastal NSR navigation

Length	180.0m
Length between perpendiculars	175.0m
Width	24.0m
Depth	16.0m
Draft	8.0m
Displacement	25,000m
Hull features	Double hull, air bubbling system
Number of propellers	1
Propulsion system	4-bladed controllable-pitch propeller (conventional and nozzle propellers)
Performance in ice	Continuous icebreaking at 3 knots in ice 1.2m thick
Performance in open seas	16knots

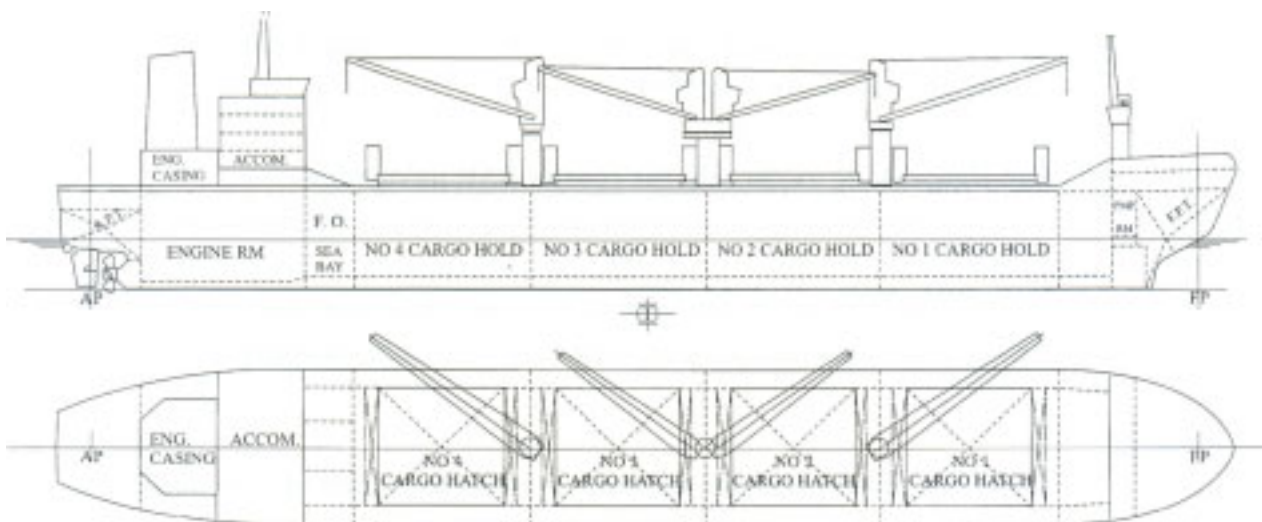

Figure B-1 General arrangement of one of the designs for a coastal NSR commercial vessel

calculations. To do this, ship designs combining the three bow types and two stern types shown below were examined.

Bow A : Conventional icebreaker bow form with relatively simple V-frame lines

Bow B : Spoon bow form with more convex frame lines than A

Bow C : Bow form with more concave frame lines at the load waterline than A

Stern a : Marina stern with moderate U-frame lines

Stern b : U-frame lines accentuated near the bottom

A comparison of the body plans of these ships is shown in Figure B-2. Model tests were conducted with combinations of the above bows and sterns. These combinations are indicated below by letter: for example, a ship that combines bow A with stern a is given the designation A-a. The combinations of the two propulsion systems are indicated CP for conventional propeller and NP for nozzle propeller, so that ship design A-a is further divided into A-a (CP) and A-a (NP).

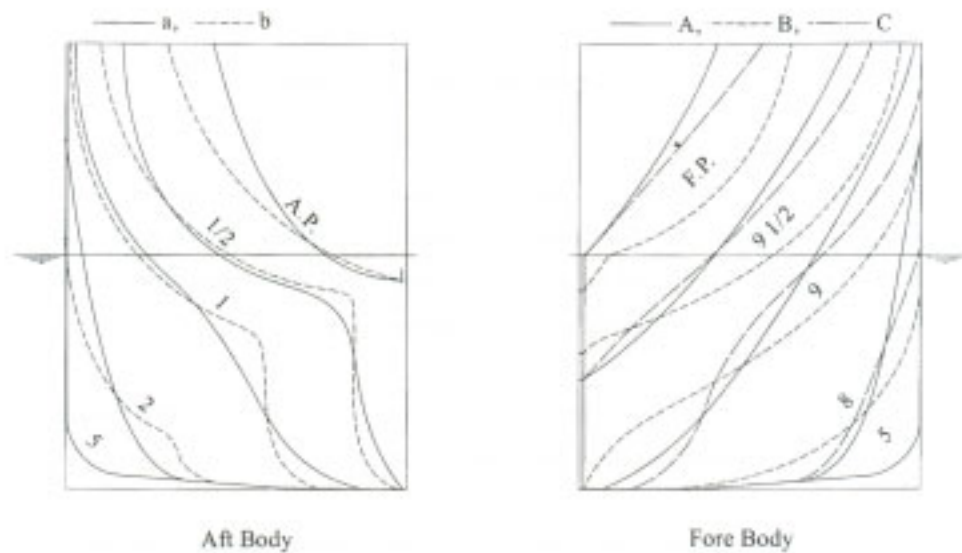

Figure B-2 Body plans of coastal NSR commercial vessels tested

1.2 Tank tests

After the basic design work was completed, each ship type was subjected to tank tests, in model ice and open water. The work for these tests was divided among the Shipping Research Institute (SRI) of Ministry of Transport, NKK Corporation (NKK) and Mitsubishi Heavy Industries, Ltd.(MHI). For the model tests, models were prepared for each of the above ship types on a scale of 1:36 and tested in turn by each of the three agencies above. The sizes of the ice model basin of each agency and their types of model ice are summarized in Table B-2.

Table B-2 Ice model basins for the model tests

	SRI	NKK	MHI
Length, m	35.0	20.0	20.0
Width, m	6.0	6.0	9.0
Water depth, m	1.8	1.8	2.3
Towing speed	0.1 ~ 2.0m/s	0.005 ~ 1.5m/s	0.001 ~ 1.0m/s
Major crystal texture of model ice	Columnar	Fine-grained	Columnar
Dopant	Propylene glycol	Urea	Urea

Appendix

SRI, NKK and MHI conducted four kinds of model tests in ice: resistance test in level ice, self-propulsion test in level ice, turning test in level ice and resistance test in a ridge. The details of each test are described below.

* Resistance test in level ice

This test is the most basic test of ship performance in ice. As Table B-1 shows, the ship is expected to be able to maintain a speed of 3 knots while performing continuous icebreaking in ice 1.2m thick. Focusing on these requirements, the test conditions were set as in Table B-3. Under the stipulated conditions, a ship model was towed in level ice, and the resistance and motions of the ship were measured. Before the model test, mechanical properties of the model ice, such as its Young modulus and flexural strength, were measured as well.

Table B-3 Test conditions in level ice (resistance and self-propulsion tests)

	Ship	Model
Ice thickness	0.9, 1.2, 1.8m	25.0, 33.3, 50.0mm
Flexural strength of ice	800kPa	22kPa
Ship speed	1, 3, 5, 7kn	0.086, 0.257, 0.429, 0.600m/s

* Self-propulsion test in level ice

The self-propulsion test in level ice was conducted under the same test conditions as the resistance test. Under the stipulated conditions, the ship model was made to run under its own power, and thrust, torque and number of revolutions of propeller as well as the motions of the model were measured. Before the model test, mechanical properties of model ice were measured.

* Turning test in level ice

The turning ability of the model was tested in level ice of 33.3mm thick (proportionate to 1.2m in full-scale). The turning tests were carried out at the rudder angles of 15 ° and 30 °.

* Resistance test in a ridge

The highly active ice movement in the coastal seas of the Russian Arctic accompanies a deformation process of sea ice. The presence of ridges is a great hindrance to the navigation of ships. A variety of ice ridges were therefore simulated in the tank tests as well, and the model resistance was measured as it passed through them.

Model tests in open water were also carried out. These tests included a self-propulsion test in calm water, manoeuvring test and seakeeping test in waves. Each test is described below.

* Self-propulsion test in calm water

The self-propulsion tests were conducted at a range of speeds from 0.5m/s to 1.7m/s. This range includes the speed 1.37m/s, which is equivalent to 16 knots in full scale. Bow type A was combined with both stern types and both propeller types, and the model tests were carried out in the four combinations A-a(CP), A-a(NP), A-b(CP) and A-b(NP).

* Manoeuvring test in calm water

To evaluate the manoeuvrability, a turning test, reverse spiral test and zigzag test were conducted with models consisting of the combinations of all three bows with stern a and an ordinary propeller: A-a(CP), B-a(CP) and C-a(CP).

* Seakeeping test in waves

The self-propulsion tests were carried out in regular head waves. To evaluate the effect of bow type on thrust increase and spray generation at the bow, the models had stern a and the ordinary propeller

combined with each bow type in three combinations: A-a(CP),B-a(CP) and C-a(CP). The ratios of wave length to ship length were varied between 0.75 and 2.00, simulating wave height in the Bering Sea, where average wave height is 4.07m.in winter.

In addition to the above tests, wake measurements and the propeller test in open water were also conducted.

1.3 Test Results

On the basis of the test plans summarized above, each of the three research organizations conducted its own series of tests, using its own tanks. Not surprisingly, the tests provided copious data and prolific results on the performance of ships. Therefore, the following discussion will be restricted to the main results only.

* Test results in ice

The results of measurement of icebreaking resistance in each ship type appear in Figure B-3. Because icebreaking resistance is largely dependent on the shape of the bow, only one stern type, stern a, was combined with all three types of bow. To confirm the effect of the stern, some tests were also conducted with the combination A-b. No significant difference with A-a, however, was found for model A-b. The

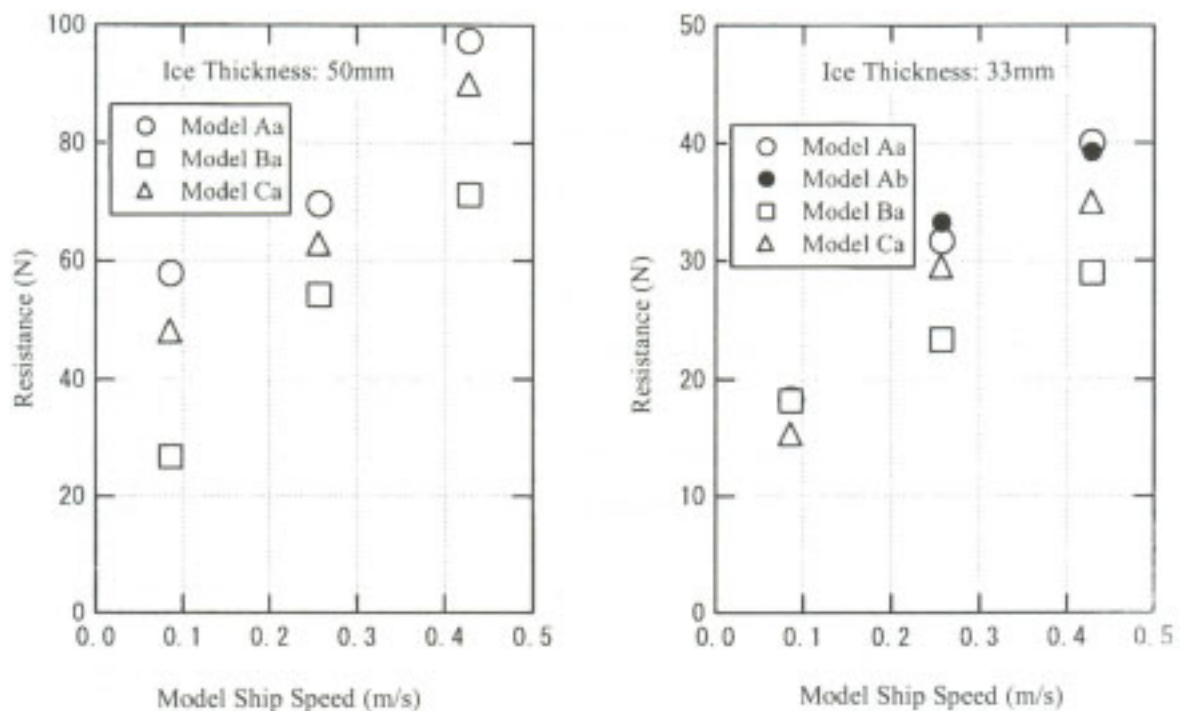

Figure B-3 Results of resistance test in level ice

test results indicate that the ice resistance of bow B is apparently lower than the others. The next best bow type was C, with the worst resistance exhibited by the conventional wedge-type bow A.

An example of the torque coefficient obtained by the self-propulsion tests in level ice appears in Figure B-4. The solid lines in the figure are the results of an overload test conducted in open water. In the self-propulsion tests in level ice, interactions between the propeller and ice fragments generally raise the torque coefficient higher than in the results of the open-water overload test. A similar tendency was also obtained in this case. However, the results of self-propulsion tests with twin-propeller ships in ice were reported in some cases to be as high as twice the results for overload tests in calm water. The difference between twin-propeller and single-propeller models was found not to be significant in torque coefficient between the overload and the self-propulsion tests. One of the reasons is that the single-propeller

markedly reduces interactions between the ice and the propeller in comparison with the twin-propeller. The frequency of the ice-propeller interactions during a ship-length run as a function of the Froude number is plotted in Figure B-5. Although variance in the data is large, it can be said that the frequency of the interactions is smaller with stern b than with stern a. This is because stern b has excellent ice-repelling performance, keeping ice fragments away from the propeller.

Examples of the trajectories of the ships in turning tests appear in Figure B-6. Generally, the tactical diameter in ice is larger than that in open water.

The size of the tank is so limited that it is extremely difficult to complete turns in common ice model basins. Therefore, the turning ability was judged by the sideways deviation from the original route within the time taken to travel a certain distance, as shown by the trajectories in Figure B-6. The difference in turning test results for each ship type is indicated in the next section, together with the test results for the new ship type.

To evaluate performance when moving through a ridge, the energy necessary to penetrate into and pass over a ridge was calculated from the resistance tests in a ridge. In Figure B-7 (a), examples of measurement of resistance in ridges are shown. Because the model speeds were kept constant, the energy consumed in passing through a ridge can be obtained simply by integration of the resistance during

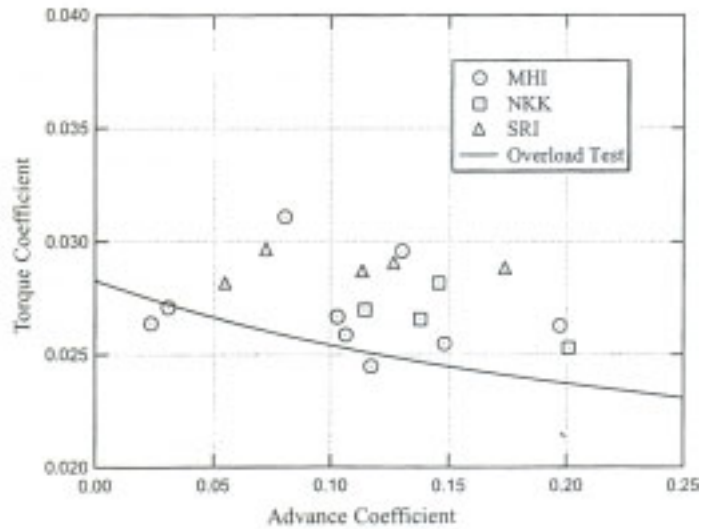

Figure B-4 Torque coefficients derived from the self-propulsion tests in level ice

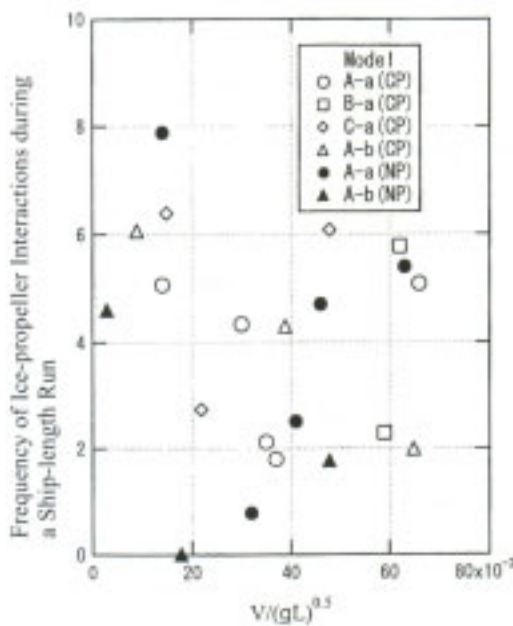

Figure B-5 Frequency of interactions between ice and propeller

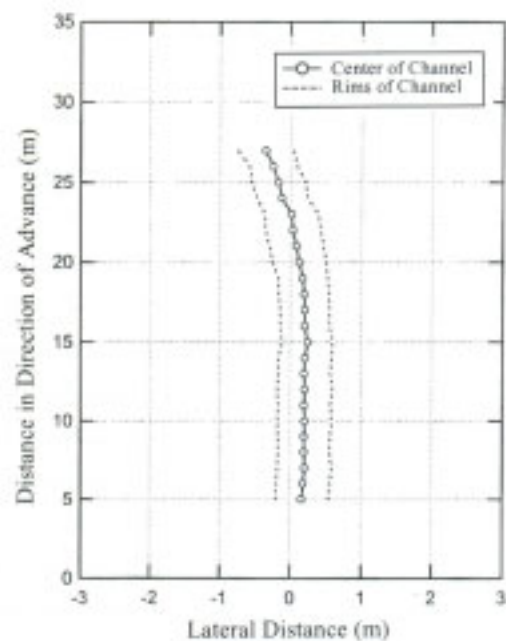
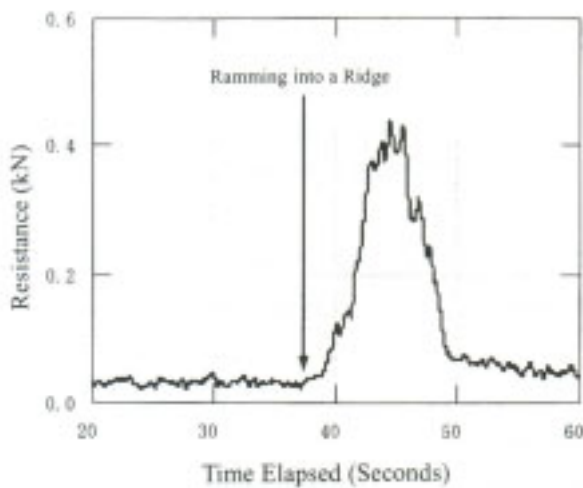

Figure B-6 Examples of ship trajectories in turning tests in level ice

passing over a ridge, multiplied by the model speed. (Figure B-7(b)). The sudden rise in energy consumed at the center of the figure represents the energy consumed to break into the ridge. The energy was calculated for each test result and expressed as a function of the cross-sectional area of the ridge as seen in Figure B-8. The figure shows that bow C requires more energy to pass over a ridge than the other two bows do. The energy is affected by vertical motion of the model in the ridge, which causes the difference in the energy. The bow is lifted high up due to high incipient resistance in the ridge, while the contact between the ice and the hull is predominant in the vicinity of the bottom of bow. Bow C' concave frame lines and entrance angles of waterlines close to contact area with ice resulted in high resistance when running into a ridge.

* Test results in open-water

The self-propulsion factors obtained from the self-propulsion tests in open water appear in Figure B-9. To highlight the effect of stern type on self-propulsion performance, combinations of bow A and each stern form were examined. Although the thrust deduction coefficient ($1-t$) shows almost no difference between the sterns, the wake fraction ($1-w$) is smaller for stern b than for stern a. This is believed to be due to two features of stern b. First, the frame line of stern b features a prominent knuckle that decreases the displacement around the stern, below the water line. Second, the salient U-shaped frame line close to the bottom stimulated the growth of boundary layer around the stern and bilge vortices. Turning test



(a) Resistance

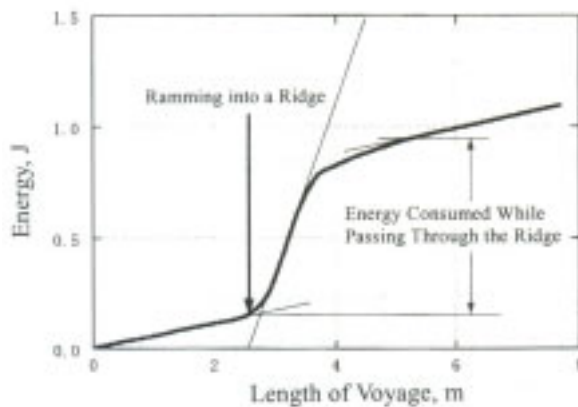

(b) Energy Consumption

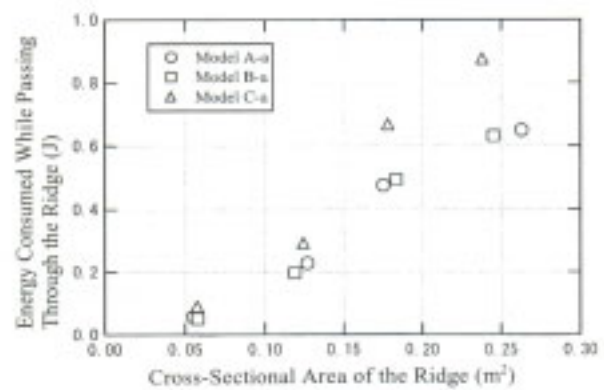

Figure B-8 Energy consumed in a ridge

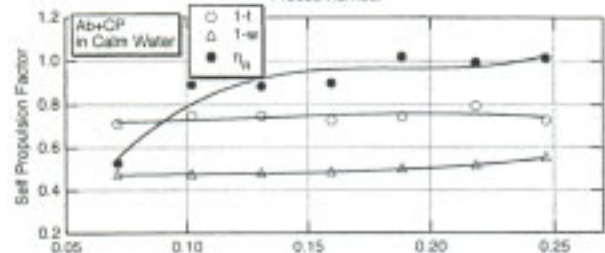
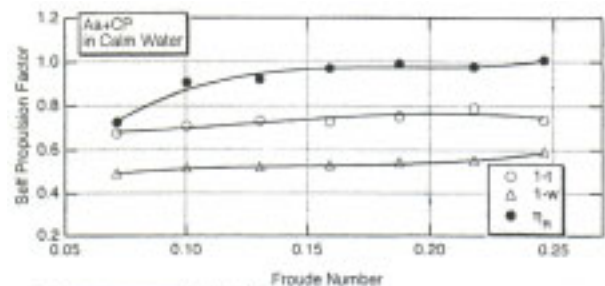

Figure B-9 Self-propulsion factors in calm water

Figure B-7 Resistance test through a ridge

Table B-4 Results of turning tests in calm water

	Ship speed (knots)	Rudder angle (degrees)	Ratio of turning circle to ship length	Ratio of advanced distance to ship length	Ratio of tactical diameter to ship length
A - a(CP)	10	+ 30	3.4	3.2	1.4
	10	- 30	2.9	3.1	1.2
	3	+ 10	3.5	3.1	
A - a(NP)	10	+ 30	3.4	3.4	1.4
	10	- 30	3.1	3.1	1.2
B - a(CP)	10	+ 30	3.4	3.3	1.4
	10	- 30	2.9	2.9	1.2
	3	+ 10	3.5	3.1	

results are indicated in Table B-4. Changing the bow and propeller type had no major effect on turning ability. The ratios of turning circle to ship length and of advanced distance to ship length were about 3:0, respectively.

The thrust increase coefficients, obtained from the seakeeping tests in waves, are shown in Figure B-10. The thrust increase coefficient was highest for bow B, particularly in the short wave range. This is because bow B has a relatively blunt entrance angle around the load waterline. In contrast, bow C had the lowest value for the coefficient, and therefore for resistance increase in waves, because of its small entrance angle around the load waterline.

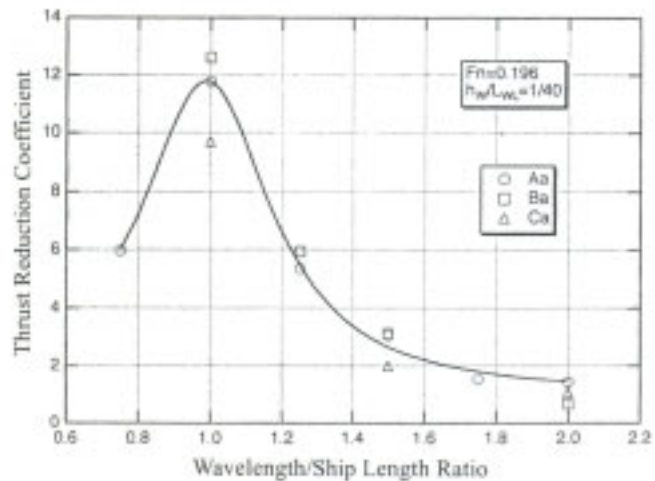

Figure B-10 Thrust increase coefficient in waves

1.4 Development of a New Ship Type and the Model Tests

The test results of various combinations of bows A, B and C and sterns a and b can be summarized as follows.

- * Bow B had the best performance in terms of ice resistance.
- * Turning performance in ice was poor in all cases. That of bow B was particularly poor.
- * Although stern b was the better of the two in terms of capability of repelling ice from the propeller disk, stern a offered the better propulsion performance.
- * Although little difference between bow types was found in terms of propulsion performance in calm water, bow A was the best, followed by B and then C.
- * Thrust increase in waves was lowest for bow C, followed by A and then B.

Taking all of these results into account, new forms of bow and stern were designed and tested.

The body plan of the newly designed ship is illustrated in Figure B-11. A new bow type was developed that incorporates the low-resistance performance of bow B and the calm-water performance of bow A. This bow has a stem angle of 25 ° (same as that of bow A) but a larger entrance angle of load waterline than bow A, to ensure excellent icebreaking capability of the stem part. To improve turning ability in ice, inclined frame lines and knuckles at the sides around the load waterline were adopted between S.S.81/2 and 9, and reamers were added

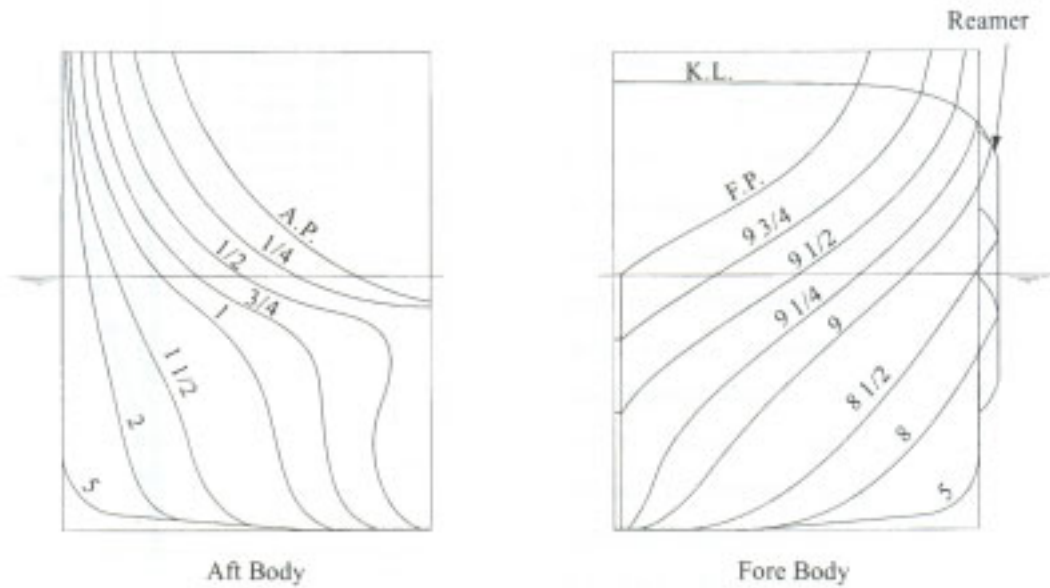

Figure B-11 New ship types (bow D and stern d)

along the knuckle lines as well. The reamer bulged to as much as 2.5% of the width of the ship. To verify the effect of the reamers on turning ability, the reamer was built as a separate, removable part of the model. When reamers were fitted, the bow was called Dr, and without the reamers it was called D. To boost the turning ability, inclined frame lines around the load waterline were adopted between S.S. 1/2 and 3 and a short parallel body was also adopted. Also, based on the stern b, which had an excellent capability of repelling ice from the propeller disk, in the newly designed stern d, the propulsion performance was improved by adopting inclined knuckle lines.

Four kinds of test in ice model basins were carried out on the new ship types Dr-d and D-d: resistance and self-propulsion tests in level ice, turning test in level ice and resistance test in a ridge. Resistance and self-propulsion tests in calm water were also conducted. All of these tests were entrusted to NKK and MHI.

The results of the resistance tests in level ice appear in Figure B-12. The resistance in bow D fell between those of bow A and B. Interestingly, the ship with a reamer, Dr, showed no significant difference with D in terms of ice resistance. This is probably because the width of the reamers was restricted to only 2.5% of the ship width, width of the parallel part of the ship. Local width of the ship at the reamer was not wider than the channel width formed by the icebreaking process, as the channel is slightly wider than the ship width. The reamers' contribution to the resistance could therefore be low. Note that ship width B used in the non-dimensional coefficient of resistance does not include the reamers.

The turning test results of the newly designed ship in level ice, together with those of bows A and B, are shown in Fig. B-13. As the figure shows, model Dr-d, the new model with reamers, exhibits the best turning ability. The turning ability of bows A and C (not shown) were roughly equal, with the

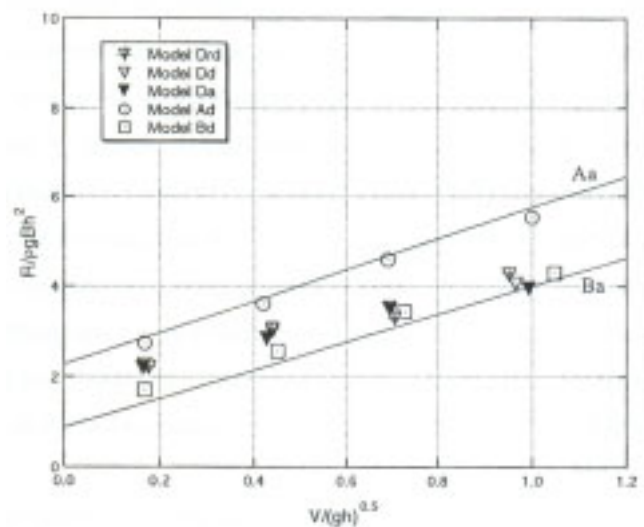

Figure B-12 Resistance in level ice

poorest ability turned in by bow B.

As for the energy to pass through a ridge, the bow Dr was in the same level with the bow A.

Fig. B-14 shows the horsepower calculated from the model test results in calm water. Horsepower of the reamer-mounted Dr-d was higher than in any of the other three designs. The form factor derived from the calm-water resistance tests was highest for Dr-d, and the high form factor resulted in high horsepower. This high form factor was partly caused by the unfavorable distribution of displacement of the aft body. Although this could not be confirmed directly, the separation of flow at the reamers might lead to a somewhat higher form factor. By effectively modifying the reamer shape, with careful consideration of viscous flow field around the aft body, the Dr design with reamers can be expected to yield a notable improvement in its horsepower.

1.5 Evaluation of Hull Forms

Once all of the above results were in, each hull form was evaluated. Preferably, this evaluation would have been conducted using operation simulations as shown in Section 4.4. Unfortunately, detailed environmental data, particularly data about ice conditions in the NSR, were not yet ready at the time this research was conducted. Simulation tests were therefore not possible, and the evaluation of the hull forms was made only qualitatively. The hull forms were evaluated according to five criteria: propulsion performance in level ice, turning ability in level ice, passing capability in a ridge, propulsion performance in calm water and seakeeping performance in waves. Evaluation was conducted by placing each hull form in one of five ranks using the test data to derive a score. Each criterion was weighted according to order of precedence, and the hull forms were finally evaluated by the total score. The weighting factor was determined by the important elements of the NSR navigation from Europe to Japan, such as the proportion of ice navigation (from the Kara Strait to the Bering Strait) to navigation in open water (from the Kara Strait to Europe and from the Bering Strait to Japan), the priorities of the performance elements in ice, etc. Nine combinations of hull forms (A-a, A-b, B-a, C-a, A-d, B-d, D-a, D-d and Dr-d) were evaluated, and the hull forms lacking in the model test data in this project were evaluated according to the data for the similar hull forms available in other sources.

The results of the evaluation are given in Table B-5. Under this way of evaluation, the hull form with the highest total evaluation points is Dr-d, reflecting Dr-d's superior total performance in ice. It will be said that the relatively poor performance in open water was compensated by its excellent performance in ice, although this

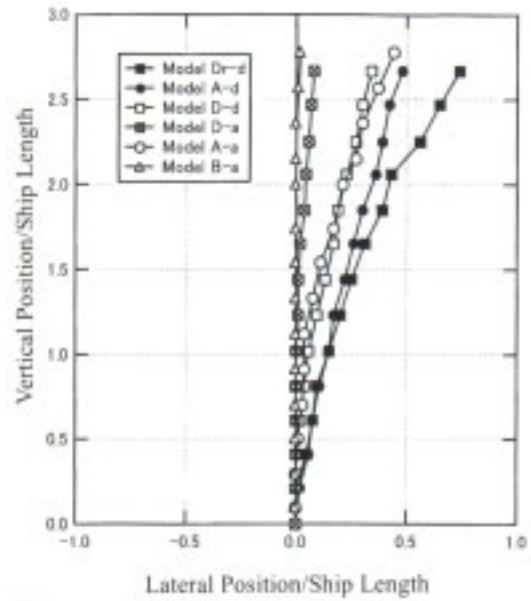

Figure B-13 Results of turning test in level ice

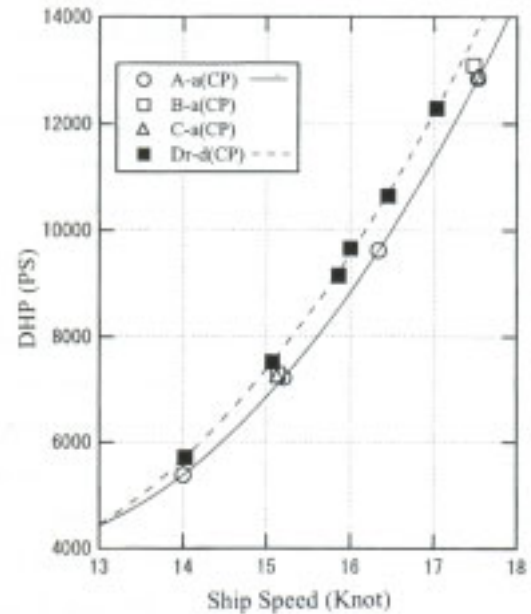

Figure B-14 Horsepower required in calm water

result partially reflects the greater weighting conferred on ice performance in this evaluation. In contrast, the hull form C-a did well in the evaluation of performance in open water, but its poor performance in ice led to a low overall evaluation score.

Table B-5 Evaluations of hull forms

Evaluation items	Weighting factor	A-a	A-b	B-a	C-a	A-d	B-d	D-a	D-d	Dr-d
Propulsion performance in level ice	8	3	2	5	3	3	5	4	4	4
Turning ability in level ice	4	3	3	2	3	4	2	2	3	5
Passing capability in a ridge	4	5	5	5	3	5	5	5	5	5
Propulsion performance in calm water	2	5	5	5	5	5	5	5	5	4
Seakeeping Performance in waves	2	5	5	5	5	5	5	5	5	4
Total evaluation score		74	66	82	68	78	82	78	82	86

Based on the results in Table B-5, Dr-d was determined to be the optimum design for an icebreaking cargo ship operating under the anticipated conditions of NSR coastal navigation; its performance in ice and open water are summarized in Figure B-15. Assuming 85% of the maximum output of 24,000HP as the normal and 15% as the sea margin, the finally designed vessel was estimated to reach speeds of 18.1 knots in open water. In level ice, again with 85% of maximum output, the vessel was estimated to be capable of continuous icebreaking in 1.2m-thick ice, at a speed of 3.3 knots.

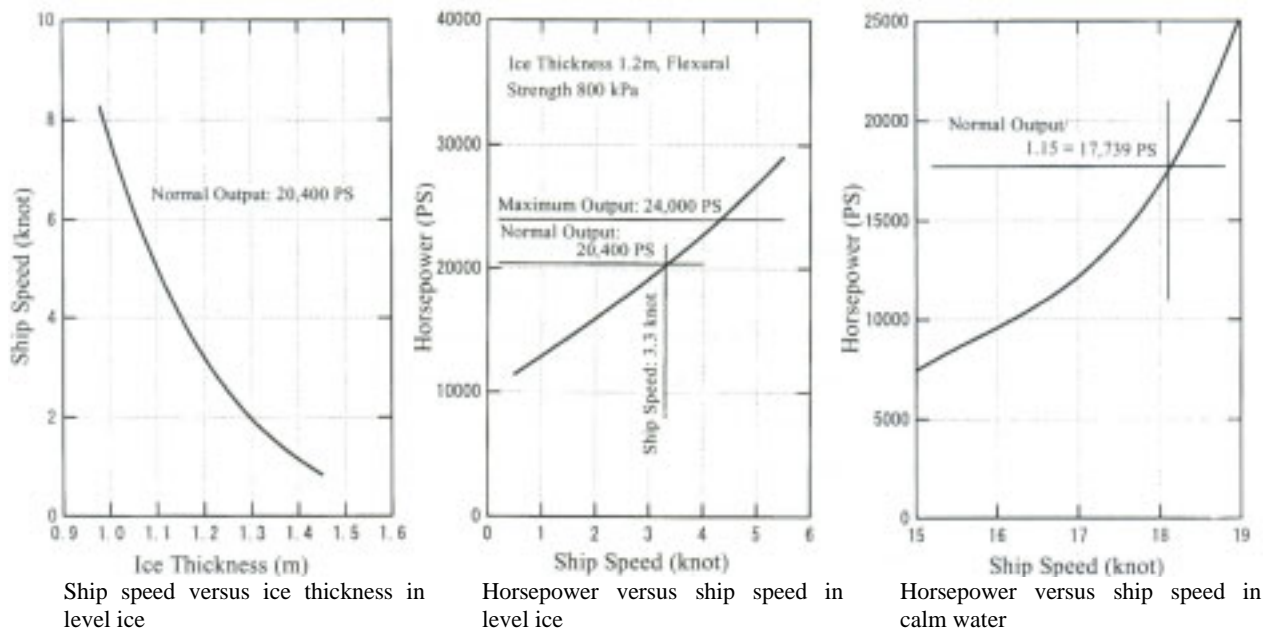

Figure B-15 Performance of the optimum ship for coastal NSR navigation

2. Development of Icebreaking Cargo Ship for the NSR Northerly Route

As with the effort to develop a coastal NSR commercial vessel as described above, the development of an icebreaking cargo ship in deep water for the northerly route of the NSR proceeded in order through the phases of basic planning, tank testing and evaluation of results. Because this research had to be completed within a relatively short span of time in coordination with INSROP, however, the comparison and examination of the performance of each ship type in tank tests was excluded. Instead, the performance data from the various shallow-water designs developed in Phase I were used in the design of the deep-draft ship.

2.1 Basic Plan

The objective of this research project was to develop an icebreaking cargo vessel that could navigate the deep outer waters of the NSR between Japan and Europe without stopping at ports along the way. Critical to the design of this ship is its ability to compete economically with other sea routes, such as the Suez Canal route. First, to decide which ship types to focus research on, container ships and bulk carriers were studied, with an eye on the current state of cargo shipping between East Asia and Europe and future trends. Container ships, it was determined, are likely to attract the greatest increase in demand in the field of logistics, but their key advantages of fast and regular navigation suggest that they offer no advantage to the NSR over other sea routes. Bulk carriers, on the other hand, do not suffer as great a loss in speed in ice-covered waters as container ships do, and the demand for the cargo in general was expected to be relatively high. For these reasons the bulk carrier was chosen as the target ship type.

Because the ship was intended for navigation of the deep waters of the NSR, the restrictions on draft encountered in the work on coastal NSR vessels were less severe. Therefore, to improve the competitiveness of the NSR ship in comparison with the ships plying the Suez Canal route, the deep-draft NSR ship was designed to have the largest displacement possible for the expected route. In addition to having ship icebreaking capability equivalent to the shallow-draft NSR vessel developed in the Phase I, the excellent performance in open water was considered to be vital in shortening the total voyage-days. The main features required for the new vessel with deep draft are as follows.

- * Main dimensions: In consideration of the shallowest section of the intended route, the Sanikov Strait, the ship's draft (d) was set at 12.5m. The width of the ship (B) was set at 30m, the broadest possible given the width of the escorting icebreaker. Based on these values and correlation data between the main dimensions of icebreaking cargo ships in service, the length between perpendiculars was set at $8B$ and the ratio D/d , where the depth, D , was placed in the range of 1.4-1.5.
- * Hull form: Based on the results of Phase I, hull form D-d was selected as the design base, as this hull form represented a favorable balance between the performance in ice and in open water. The greater length-width ratio of the deep draft ship than the shallow-draft models was realized by lengthening the parallel body. The block coefficient of the ship was to be in the range 0.75-0.77.
- * Ship structure: A double-hull structure of the ice class IA Super was selected.
- * Displacement, deadweight: Given the dimensions, kind of ship and features of the aft body selected above, the ship's displacement was estimated at 71,000t. Given the ice-strengthened and double-hull structure of the ship, its light weight was estimated at 20,000t and its deadweight was planned at 51,000t. This deadweight will fall in an extension of those of existing ships (Figure B-16).
- * Icebreaking performance: The ship is expected to be capable of continuous icebreaking at 3 knots in ice 1.2m thick.
- * Sea speed in calm water: Taking account of speed loss in ice-covered water, the sea speed

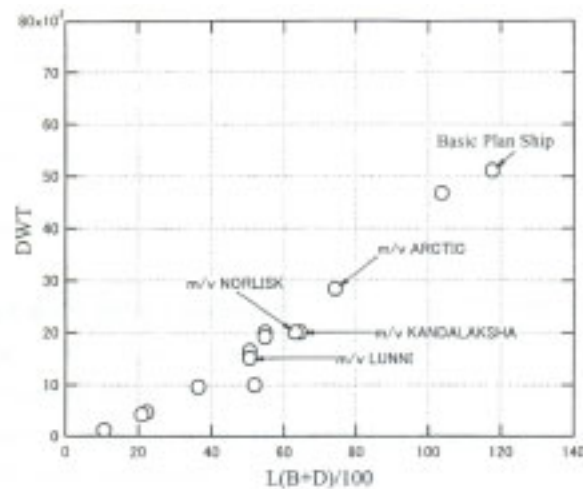

Figure B-16 Deadweight versus ship sizes of icebreaking cargo ships

Table B-6 Principal particulars of the deep-draft NSR ship

Length		252.0m
Length between perpendiculars		240.0m
Width		30.0m
Depth		18.0m
Draft		12.5m
Displacement		70,900m ³
Deadweight		50,900m ³
Main engine output	(Maximum continuous rating)	24,160PS
	(Normal rating)	21,750PS
Number of propellers		1
Propeller		4-blade, fixed-pitch propeller
Performance in ice		Continuous icebreaking at 3 knots in ice 1.2m thick
Performance in calm water		17 knots

in calm water was set at 17 knots, in order to exceed the number of voyages between Hamburg and Yokohama via the Suez Canal using the current Panamax bulk carriers.

- * Engine: For reasons of economic performance, a low-speed diesel engine was selected. Horsepower required for icebreaking was estimated at 21,000HP, on the basis of the regulations of classification societies and operation experiences of comparable icebreaking cargo vessels. In open water, normal output was set at 21,750HP, based on a 20% increase in horsepower over the similar Panamax bulk carriers, taking account of power margin due to the difference in their hull forms. This means that the main engine output of the deep-draft NSR ship was determined by the horsepower required for navigation in open water. At the initial design stage, the maximum output of the ship's engine was set at 24,160HP.
- * Rudder: A mariner-type rudder was used.
- * Propeller: conventional, fixed-pitch propeller.

The principal particulars and the body plan of the ship are illustrated in Table B-6 and Figure B-17 respectively.

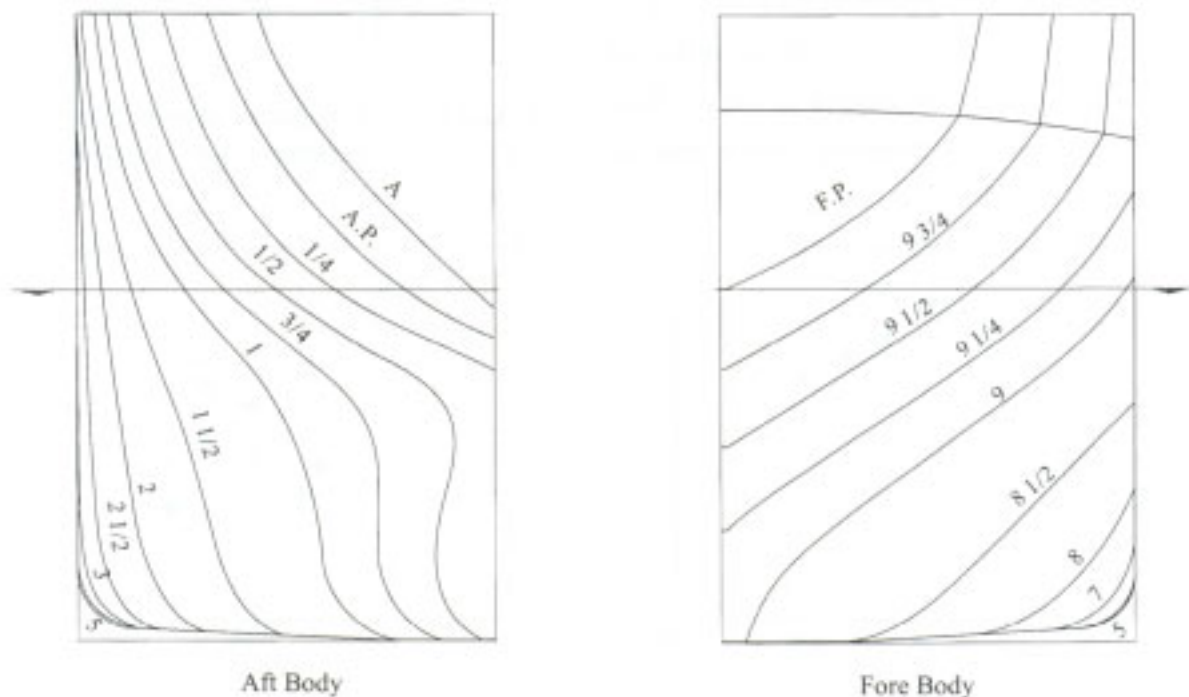

Figure B-17 Hull form of the deep-draft NSR ship

2.2 Tank Tests and their Evaluation

A single model was used for all tests. Built at a scale of 1:43.64, the length between perpendiculars of the model was 5.5m. Three kinds of tests were conducted in level ice: resistance test, self-propulsion test and resistance test in a ridge. In calm-water, resistance test, self-propulsion test, overload test, turning test and self-propulsion test in waves were all carried out. For each test the approach was essentially the same as that followed in Phase I. All tests were conducted by NKK except the test in a ridge and seakeeping test, which were entrusted to SRI.

The results of the resistance test in level ice are shown in Figure B-18. For comparative purposes, the results for ship D-d in Phase I are added in the figure for comparison. Although the two models had almost the same resistance in level ice, a slightly higher resistance of the present model is attributed to the increase in frictional resistance of the lengthened parallel body and resistance increment caused by deep submergence of broken ice fragments by the deeper draft. The frequency of interactions between ice fragments and the propeller was examined in the self-propulsion test (Figure B-19). In comparison with ship D-d in Phase I, the deep-draft ship had a lower frequency of interactions. The longer parallel body of the deep-draft ship could probably make it easier to clear out the ice fragments in the propeller disk. The thrust deduction coefficient and wake factor are plotted in Figure B-20. The relationships among horsepower, speed

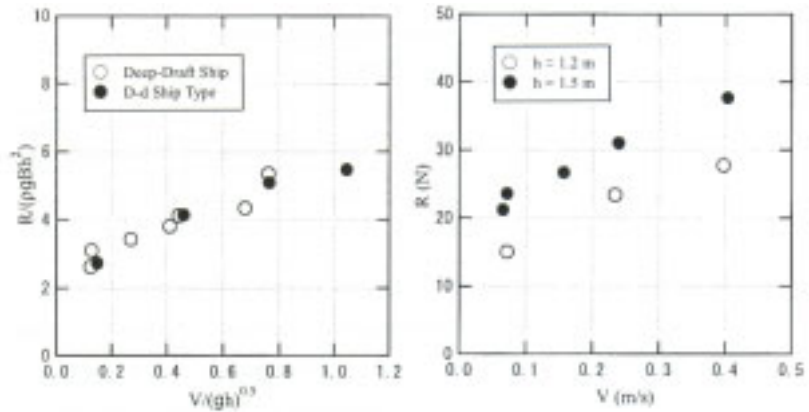

Figure B-18 Results of resistance tests in level ice

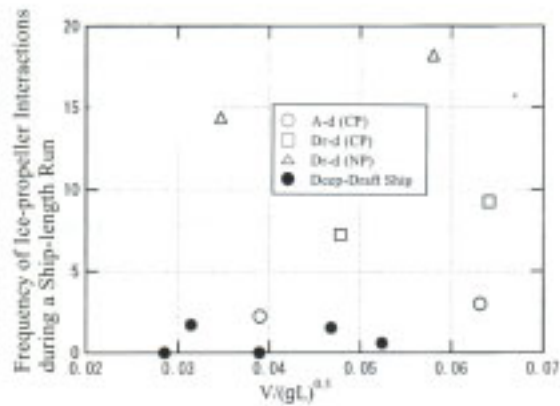
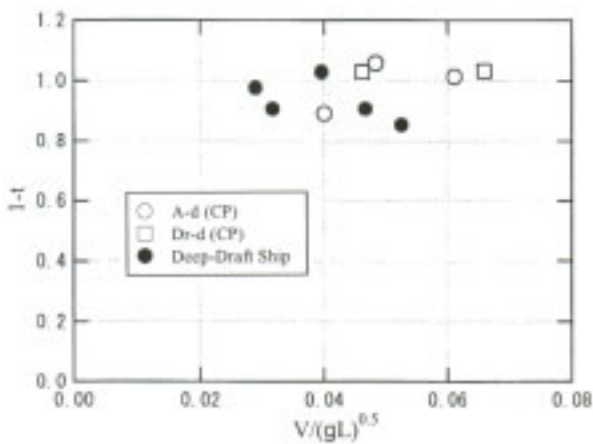
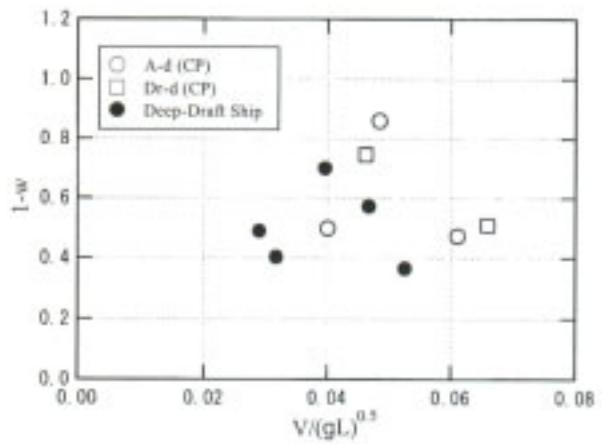

Figure B-19 Frequency of interactions between ice and propeller



(1) Thrust deduction coefficient



(2) Wake factor

Figure B-20 Thrust deduction coefficient and wake factor in ice

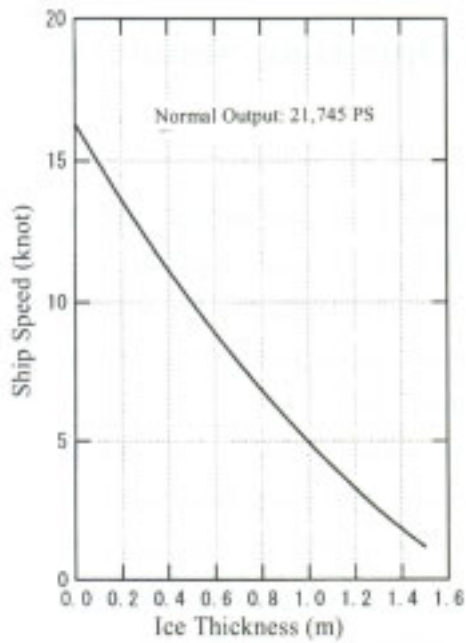

(1) Speed versus ice thickness

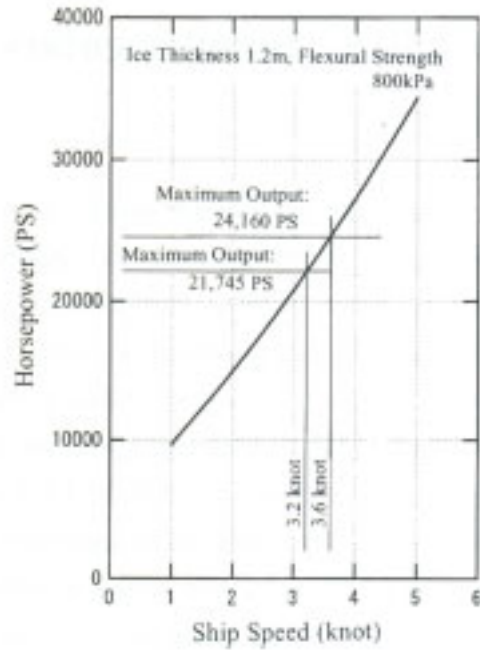

(2) Horsepower versus speed

Figure B-21 Performance in level ice

and ice thickness in the tests in level ice are illustrated in Figure B-21.

A horsepower curve obtained by the model tests in calm water is shown in Figure B-22. This figure shows that the deep-draft ship in the full load conditions can manage a speed of 17 knots at normal output (21,740 PS) and 17.45 knots at maximum output (24,160PS). If a sea margin of 15% is added to normal output, however, the ship's speed drops to 16.4 knots. The power specification was then reset to normal output of 25,000HP and maximum output to 28,000HP.

Thrust increase in waves was deduced from the self-propulsion tests in regular waves (Figure B-23) and compared with the test results in Phase I. Although no data directly compares the deep-draft ship with hull form D, on which the deep-draft ship's bow was based, the present ship had the same level of thrust increase in waves as bow C, which had the lowest thrust increase among the three bow designs A, B and C in Phase I. These results were at least as good as the existing test results for ordinary bulk carriers.

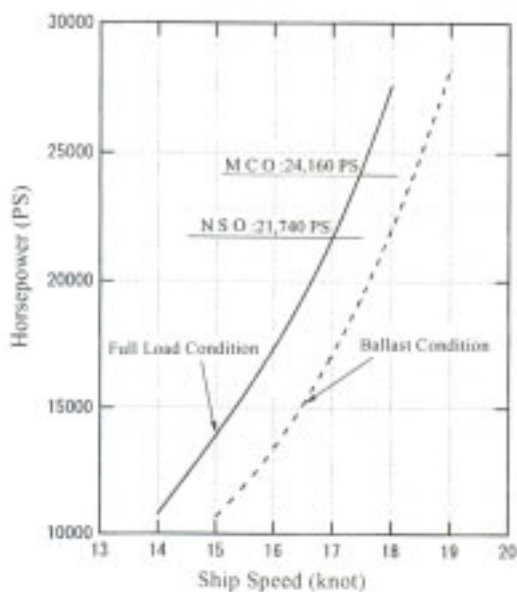

Figure B-22 Predicted horsepower in calm

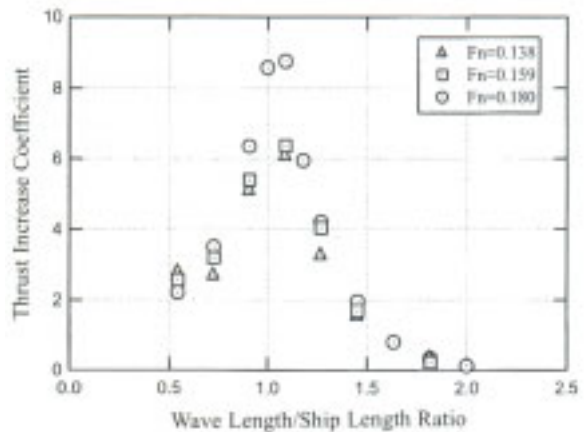

Figure B-23 Coefficient of thrust increase in waves

Appendix C: Supplementary Data on Operation Simulations

Ice data

The data provided for the INSROP project by AARI is organized into average monthly values for the 38-year period from 1953 to 1990, divided into segments of 20NM in length and encompassing 18 parameters, which are listed in Table C-1. When the number of segments is multiplied with the number of years, months in each year and number of data parameters ($I = 18$), it is clear that this is an immense corpus of data. Since the segments number 130, the total number of data items is over a million: $130 \times 38 \times 12 \times 18 = 1,067,040$. The data of cold-sum was supplemented with the data from polar stations. Data on ice concentration were gathered by aerial observation until 1978; in 1979, satellite observation took over. Parameter 6, thickness of level ice, was estimated according to an algorithm developed by Zubov, using the cold-sum data. The ice-thickness parameters 7-9 are average values including all types of ice, including multi-year ice; the average values were derived from the estimated ice thickness based on the observed values in May, when ice is thickest, and corrected for the growth and thawing rates during the year. The wind speeds and tidal flows are estimates based on forecast models. The floe size is classified into ten grades, using a model developed from aerial observation data. The average ridge sizes are estimated from the ice thickness, using the correlation between ice thickness and ridge sale height obtained from Romanov's data. The data in parameters 14 and 15 are estimates derived from average sail height distribution, which was assumed to follow the Weibull distribution. The parameters 16-18 are also estimates, derived from the correlation between observed values of ridge concentration given in five grades and the sail heights. For details, please refer to Breskin et al. (WP-121). All of this data is available on CD-ROM of INSROP GIS (1999), so that readers who need the actual data can access them. Ship speeds in the simulation were calculated using the seven parameters highlighted in bold face in Table C-1. Because observation was not possible in all areas, these data are both spatially and temporally incomplete. Overall, data is most incomplete for the eastern NSR, as sufficient observation was not feasible in some years. During the periods 1953-1956 and 1961-1964, the sufficiency rate for the observation data was 50% or lower, and these data were excluded from the base data for the simulation. Where data was not available or insufficient, an estimate was supplied using data supplemented from adjoining segments or the nearest few months. Unfortunately, the sufficiency rate for one of the important parameters, ridge density, was only 27%, so this sort of supplementation was impossible. In this case, an average value for all data was substituted for the missing ridge density data.

Table C-1 List of parameters of environmental data along the NSR

No.	Parameter	Unit	No.	Parameter	Unit
1.	Cold sum	day	10.	Wind direction	degree
2.	Average concentration of first-year ice	1/10	11.	Current direction	degree
3.	Average concentration of multi-year ice	1/10	12.	Floe size	km
4.	Minimum concentration	1/10	13.	Average ridge size (sail height)	cm
5.	Maximum concentration	1/10	14.	Maximum possible ridge size (1% expected value)	cm
6.	Thickness of level ice	cm	15.	Minimum possible ridge size (0.1% expected value)	m
7.	Average ice thickness	cm	16.	Average ridge density	1/km
8.	Minimum ice thickness	cm	17.	Minimum ridge density	1/km
9.	Maximum ice thickness	cm	18.	Maximum ridge density	1/km

To analyze trends in the supplied data, average values over about 30 years were calculated for each parameter in each sea region and each month. Figures C-1 to C-4 show data on cold sum, concentration of first-year ice, concentration of multi-year ice and ice thickness, for the northerly and the southerly routes.

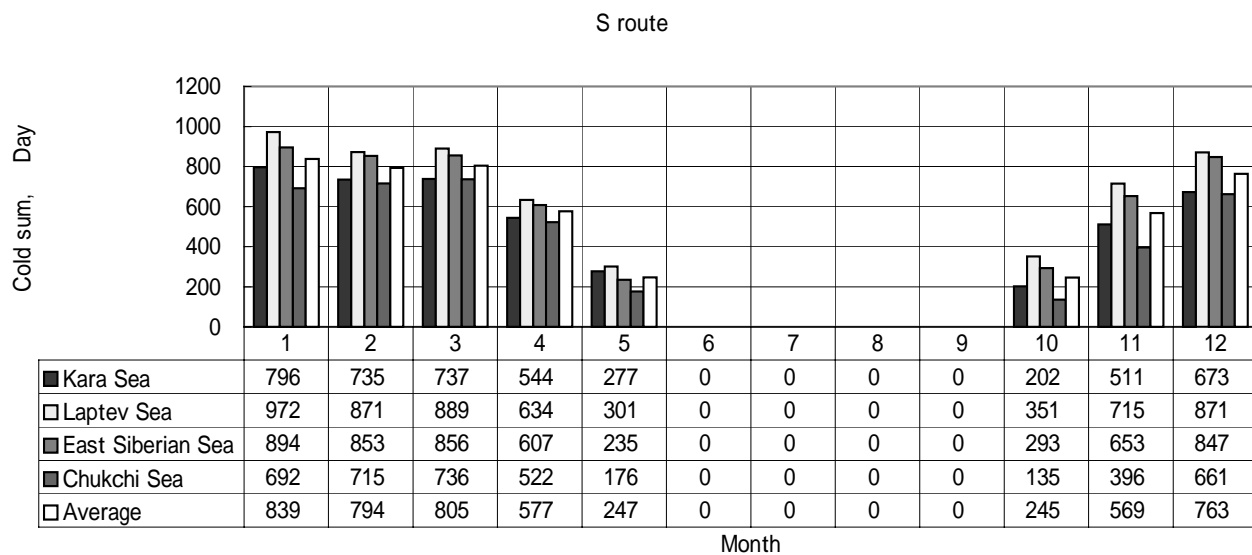
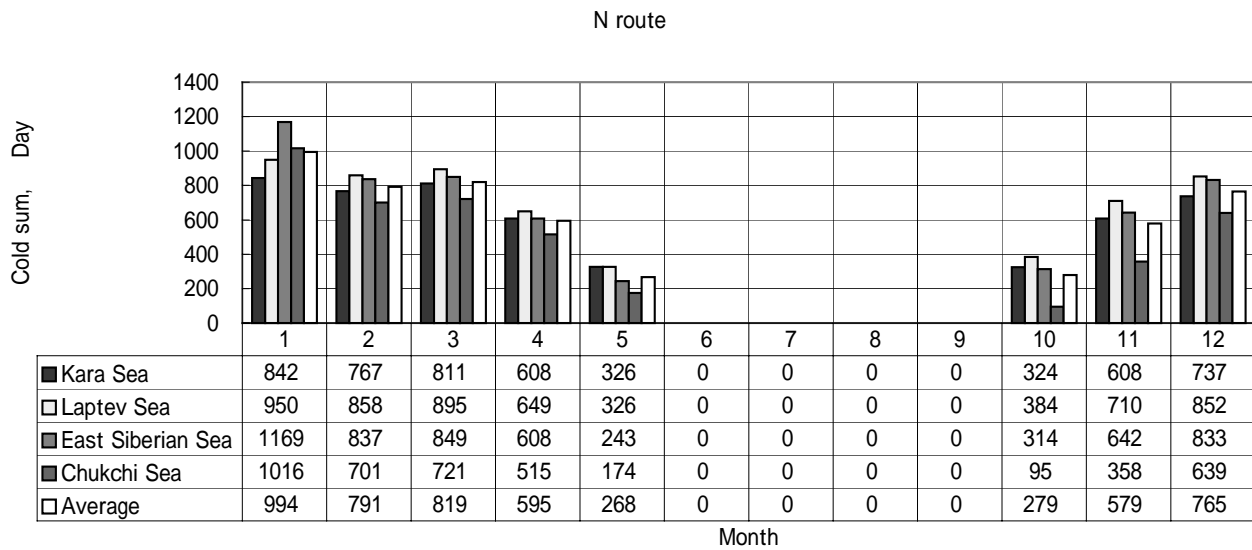

Figure C-1 Variations in cold sum by sea region and month

Appendix

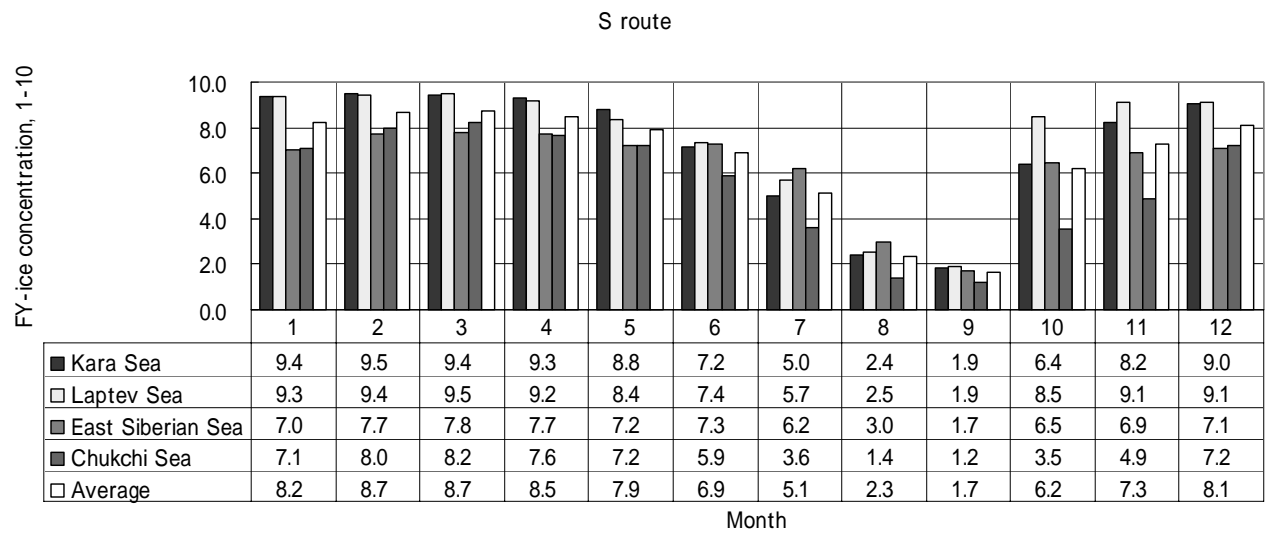
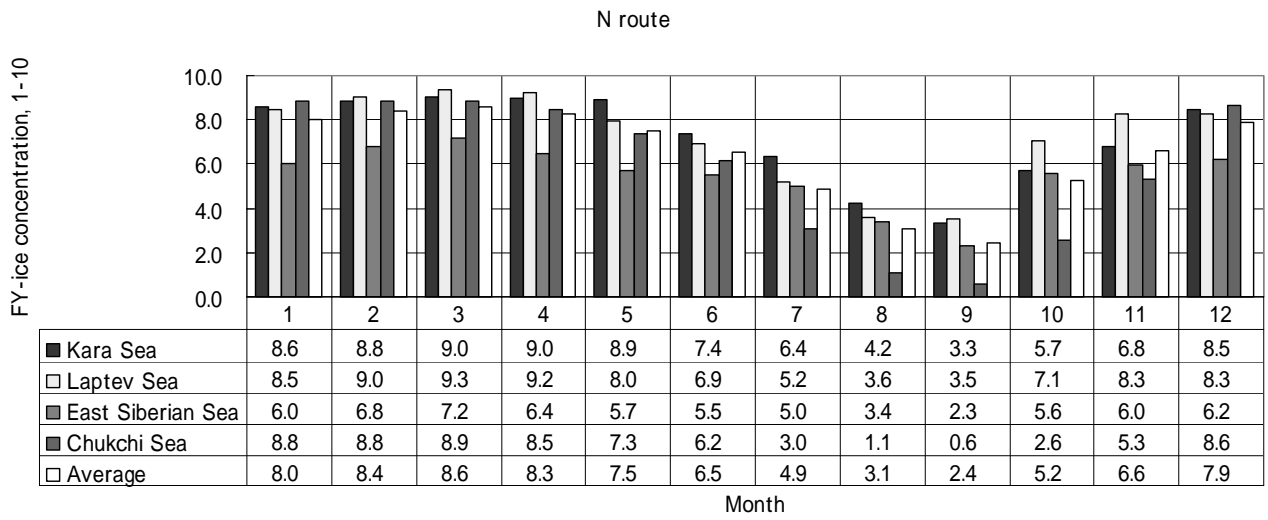

Figure C-2 Variations in concentration of first-year ice by sea region and month (top: northerly route, bottom: southerly route)

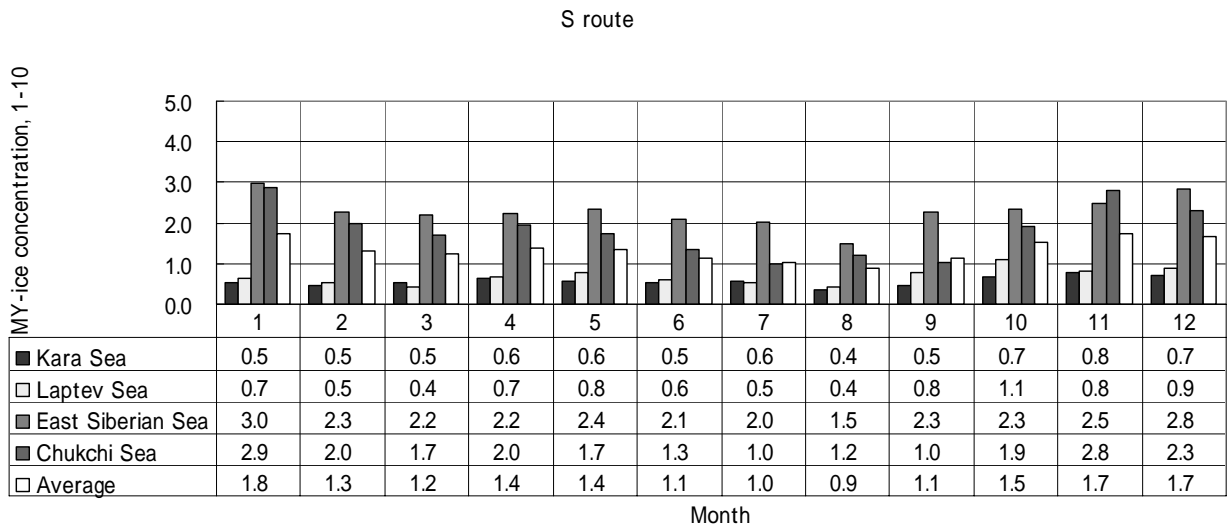
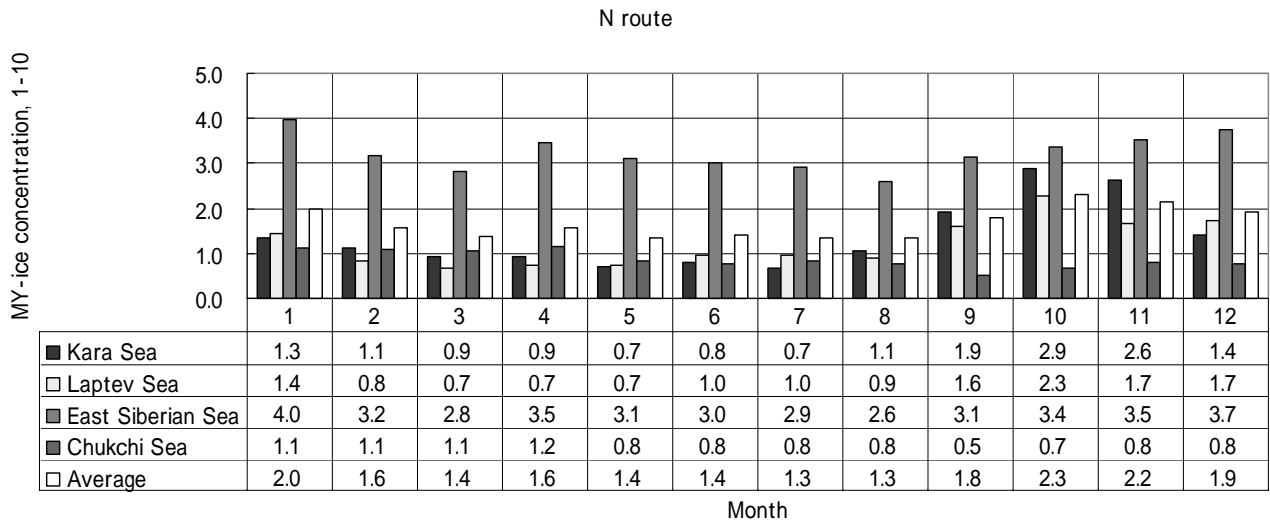

Figure C-3 Variations in concentration of multi-year ice by sea region and month (top: northerly route, bottom: southerly route)

Appendix

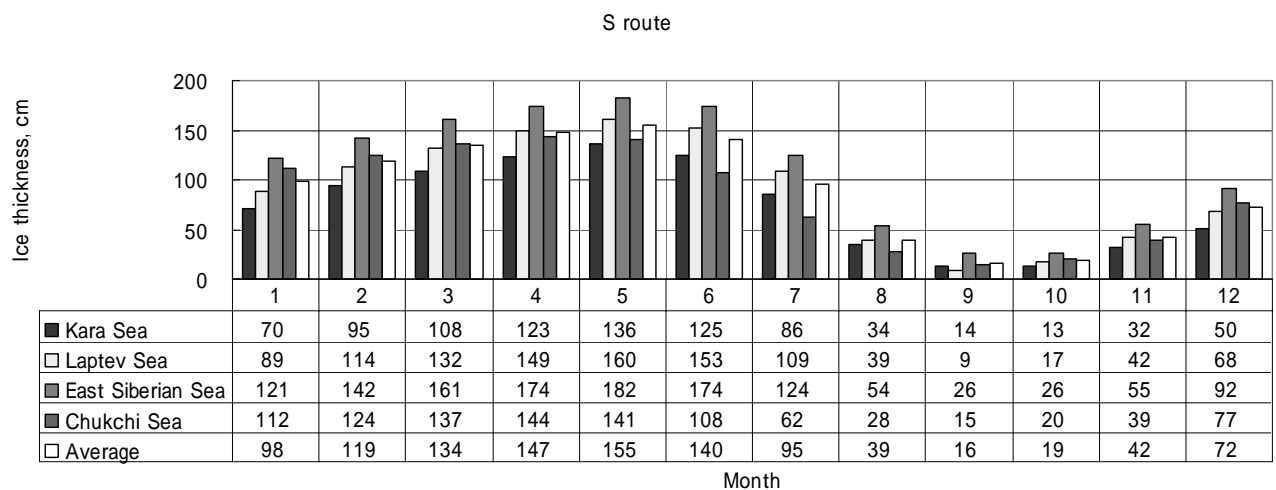
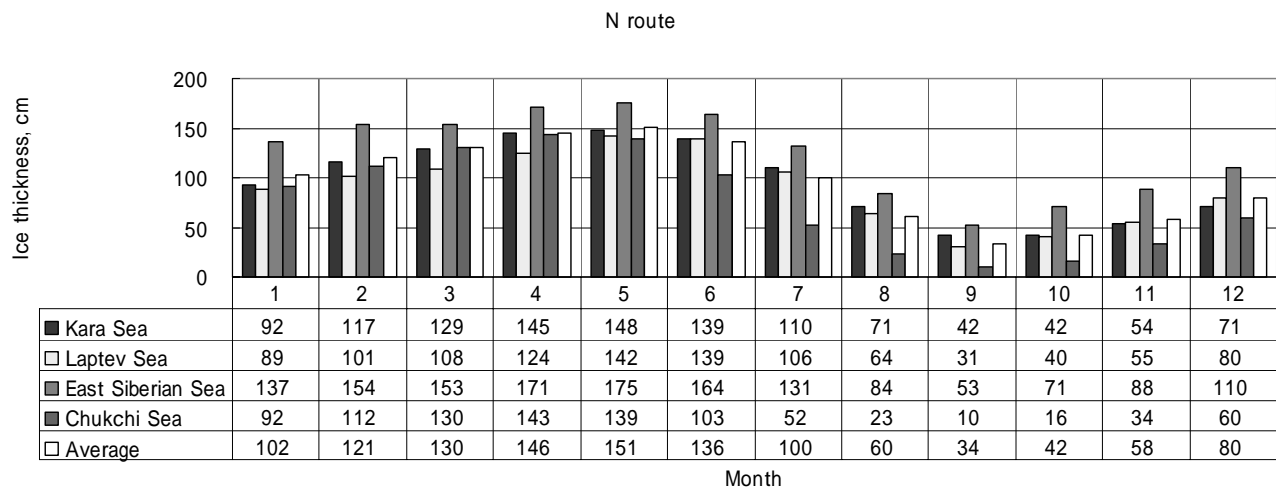

Figure C-4 Variations in ice thickness by sea region and month

Ice Index

Ice index is a quantitative parameter that represents the extent of difficulty in ice navigation. This practical concept was originally introduced in the CASPPR in Canada. The present ice index differs from the Canadian ice index in terms not only of ice type, ice thickness and ice concentration, but also in terms of the influence of ice strength, ridge size and ridge distribution.

The ice index I was defined as a sum of three kinds of ice index, as follows:

$$I = I_A + I_B + I_C$$

Table C-2 Ice types and ice multipliers

Type of ice	Ice thickness h_i (cm)	Ship category				
		Type A	CAC4	CAC3	CAC2	CAC1
Multi-year ice (MY)	-	- 3.5	- 2.5	0	2	2
Thick first-year ice (TFY)	120 h_i	- 1	1	2	2	2
Moderate first-year ice (MFY)	70 $h_i < 120$	1	2	2	2	2
Thin first-year ice (THFY 2)	50 $h_i < 70$	2	2	2	2	2
Very thin first-year ice (THFY 2)	30 $h_i < 50$	2	2	2	2	2
OW	0 $h_i < 30$	2	2	2	2	2

I_A is a basic ice parameter depending on age, thickness and concentration of ice. I_B is a ridge parameter, defined by sail height and ridge density. I_C is an ice strength parameter, which is a function of flexural strength and compressive strength of ice, to be estimated by cold sum.

Calculation of ice index

The calculation procedure of I_A is almost the same as the Canadian ice numeral. The ice multipliers given by the CASPPR for CAC4 and Type A were revised, as shown in Table C-2, which lists the various types of first-year ice and their definitions, along with the ice multipliers for each ice type and ship category. The formula for calculation of the ice index is as follows, using the ice multipliers for first-year ice and multi-year ice given in Table C-2, where C_f is concentration of first-year ice and C_m is concentration of multi-year ice.

$$I_A = (\text{corresponding ice multiplier for first-year ice}) \times C_f + (\text{corresponding ice multiplier for multi-year ice}) \times C_m + 2 \times (10 - C_f - C_m) \tag{1}$$

Ridge parameter I_B can be obtained as following. C_r is defined as an index from 1 to 10 of ridge concentration, where the ridge profile is assumed as shown in Figure C-5. Ridge concentration as defined in the environmental parameter 16 is designated by D_r , and C_r is defined according to formula (2).

$$C_r = W_k \times (D_r / 1000) \times 10 \tag{2}$$

If ridge width W_k is approximated by $W_k = 20H_s$,

$$C_r = (H_s D_r) / 5 \tag{3}$$

I_B approximates according to formula (4).

$$I_B = F(C_r) \times (C_f + C_m) \tag{4}$$

Where $F(C_r) = -2 \times (C_r / 10)$

In CASPPR's reckoning, if an area is 1/3 covered by ice ridges and ice concentration ($C_r + C_m$) is 6 or over, 1 is subtracted from the ice multipliers in Table C-2. If the area is fully occupied by ridges, i.e. $C_r = 10$, the formula (4) will give I_B value twice as high as CASPPR's one.

I_c , an index of ice strength, is defined according to Table C-3 and formula (5). The lower the air temperature, the greater the penalty and the higher penalty for multi-year ice is counted.

Appendix

$$I_C = M_{CS} \times (\text{first-year ice}) \times C_f + M_{CS}(\text{multi-year ice}) \times C_m \quad (5)$$

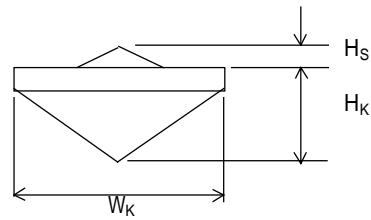

Figure C-5 Assumed ridge profile

Table C-3 Ice strength parameters

Type of ice	First-year ice			Multi-year ice			
	T -10	-10 T -2	-2 T 0	T -10	-10 T -2	-2 T 0	
Average monthly temperature T(C °)							
Flexural strength (kPa)	600	450	300	1600	1200	800	
Compressive strength (kPa)	6000	4500	3000	9000	6500	4000	
Coefficient M _{CS}	-0.12	0	0.12	-0.44	0	0.44	

To illustrate how these formulas are used to calculate the ice index, an example is provided below.

Ice conditions

- Ice thickness : 1m (MFY)
- Concentration of first-year ice : 6
- Concentration of multi-year ice : 1
- Ridge sail height : 0.5m
- Ridge concentration : 20/km
- Average monthly temperature : - 5
- Ice class : Tyop A

Sample calculation

$$I_A = 1 \times 6 + 1 \times (-3.5) \times 1 + 2 \times (10 - 6 - 1) = 8.5$$

$$C_r = 0.5 \times 20 / 5 = 2.0$$

$$I_B = -2 \times 2.0 / 10 \times (6 + 1) = -2.8$$

$$I_C = 0 \times 6 + 0 \times 1 = 0.0$$

$$I = I_A + I_B + I_C = 8.5 - 2.8 + 0.0 = 5.7$$

Next the correlation between ice index and ship speed was calculated for each ship type. Obviously, calculating this correlation for all combinations of segment, year and month in the data provided by AARI would be prohibitively time-consuming. Instead, a selection of appropriate combinations were made and a ship speed code called NEWSIM2 was used to derive the ship speeds. First, the minimum, mean and maximum were derived for the environmental parameters 2, 3, 7, 14 and 16 selected to use for the simulations and listed in Table C-1. Combinations of these parameters were used to cover the range where the ice index could be obtained. Minimum and maximum were calculated as minimum = mean - standard deviation and maximum = mean + standard deviation; these values are shown in Table C-4. With three values for each five parameter, ice index could be calculated for $3^5 = 243$ combinations. Doubtful environmental data combinations were excluded so that only the reasonable combinations were in use for ship speed calculations by NEWSIM2 code, yielding

the ship speed corresponding to the ice index. For floe size, the mean values were used. As for the ship category, the cargo vessels were assumed to be classified as Type A and the Arktika type escort icebreaker was assumed to be classified as CAC1. Navigation under conditions of high ice concentration often suffers from ice pressure caused by winds and currents. In such cases, the ship incurs a great loss in speed and may be in danger of besetting. As the predominant impact of the ice pressure effect is on the parallel body of the ship, a correction factor for this effect to the ice index, C_{CO} , was introduced according to the length of the parallel body. The factor C_{CO} is shown in Table C-5. When navigating ice-covered waters, ship masters tend to avoid severe ice areas and try to find open leads. This routing effect should also be taken into account in the ice index. Routing decisions will be made depending on the conditions of ice thickness and concentration. The correction factor for routing effect, C_{ma} was then introduced, as shown in Table C-6. As the higher the ice concentration, the greater the difficulty in changing ship course, a greater penalty was assumed for higher ice concentrations. Ship speeds were arranged in a two-rank ice index. Since ship speeds corresponding to arbitrary ice index rank were distributed among a range of speeds, the variations were arranged in five ranks in terms of probability distribution. Results for three ship types and the Arktika appear in Figure C-6. Because a single ice index may correspond to several ice conditions, ship speed was derived from a distribution of a certain range of ship speeds corresponding to an ice index rank.

Table C-4 Maximum and minimum values of ice parameters

Parameter	Unit	Minimum	Average	Maximum
Average concentration of first-year ice	1/10	2.3	6.3	10.0
Average concentration of multi-year ice	1/10	0.0	1.4	4.0
Average ice thickness	cm	27	97	168
Average ridge size (sail height)	cm	39	94	149
Average ridge density	1/km	0.0	13.9	27.7

Table C-5 Correction factor for ice pressure

Ship type	C_{co}
Arktika	0.95
25BC, 40BC	0.88
50BC	0.80

Table C-6 Correction factor for routing effect

Total ice concentration	C_{ma}
10/10 - 6/10	0.95
5/10 - 1/10	0.97

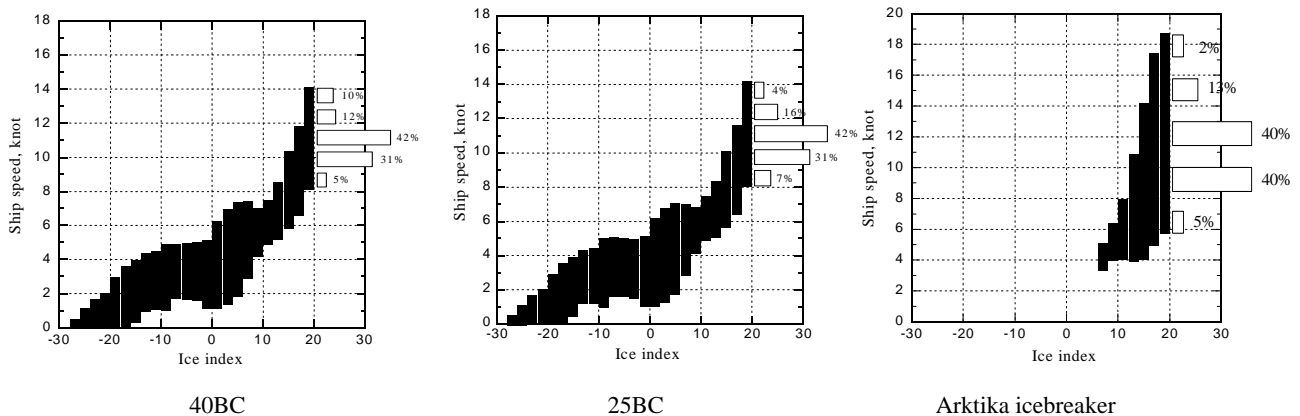
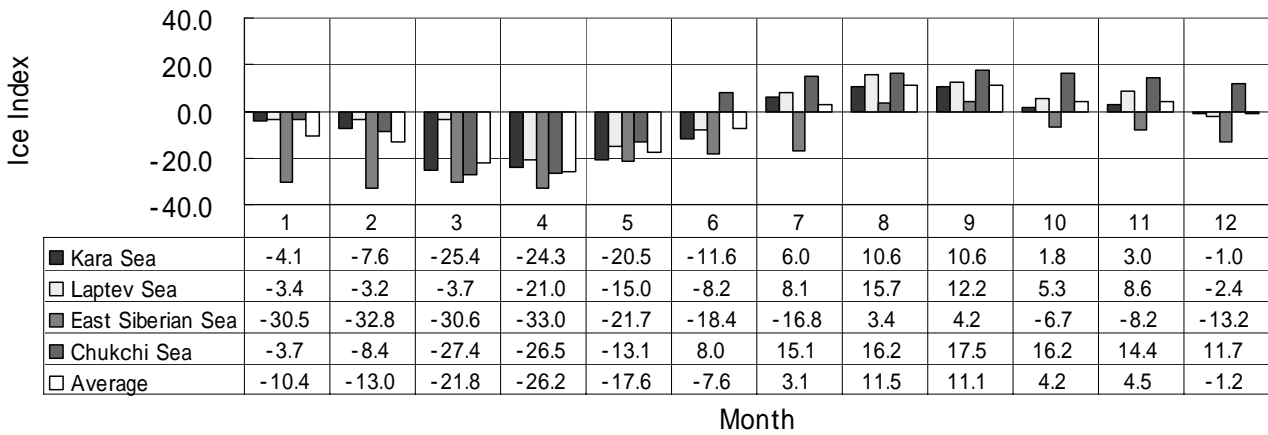

Figure 6 Ice index versus ship speed distribution

Appendix

Using the average values of environmental data for each sea region given in Tables C-1 to C-3, the ice index for Type A cargo vessels was derived for each sea region and month. The ice index and number of escorted days shown in Fig.4.4-9 (Chapter 4) were found to have the same trend. Since the East Siberian Sea has a high proportion of multi-year ice and the most treacherous ice conditions. In the Laptev Sea, landfast ice develops in winter. Consequently, navigation in the southerly route is clearly understood to be more difficult than the northerly one.

N-Route



S-Route

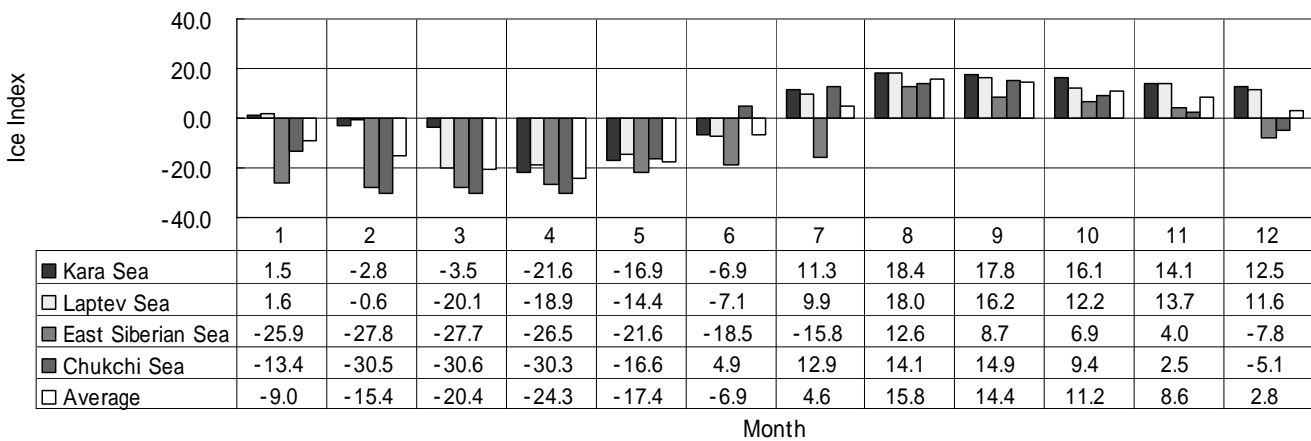

Figure C-7 Monthly changes of ice index in each sea region (top: northerly route, bottom: southerly route)

Supplement to results of calculation of operating costs

Table C-7 Breakdown of total cost of one voyage for each of three ship types, by month (transit voyage)

(Average values for 1957-1990) (Unit: 1,000US\$)

Month	Capital cost			Operating cost			Port fee			Fuel cost			Icebreaker fees, etc.			Total cost		
	25 BC	40 BC	50 BC	25 BC	40 BC	50 BC	25 BC	40 BC	50 BC	25 BC	40 BC	50 BC	25 BC	40 BC	50 BC	25 BC	40 BC	50 BC
1	754	894	384	260	270	279	61	67	92	237	242	164	121	126	163	1433	1599	1082
2	799	907	393	275	274	286	61	67	92	183	174	127	126	130	167	1444	1552	1064
3	806	901	397	278	273	289	61	67	92	165	145	128	127	131	167	1438	1517	1074
4	780	882	387	269	267	282	61	67	92	150	128	122	127	131	167	1388	1474	1049
5	716	823	361	247	249	263	61	67	92	143	131	127	125	129	164	1292	1399	1008
6	628	720	310	216	218	226	61	67	92	113	110	118	122	126	161	1140	1241	907
7	634	733	320	218	222	233	61	67	92	148	152	149	122	128	166	1184	1302	959
8	551	649	281	190	196	205	61	67	92	182	207	185	116	122	160	1100	1242	923
9	536	629	268	185	190	195	61	67	92	168	186	175	116	121	160	1067	1194	890
10	577	661	285	199	200	207	61	67	92	205	198	172	117	123	162	1159	1250	918
11	666	728	330	229	220	240	61	67	92	287	265	224	113	118	154	1357	1399	1041
12	711	813	346	245	246	252	61	67	92	291	279	190	116	121	158	1423	1527	1039
平均	680	778	339	234	235	246	61	67	92	189	185	157	121	126	162	1285	1391	996

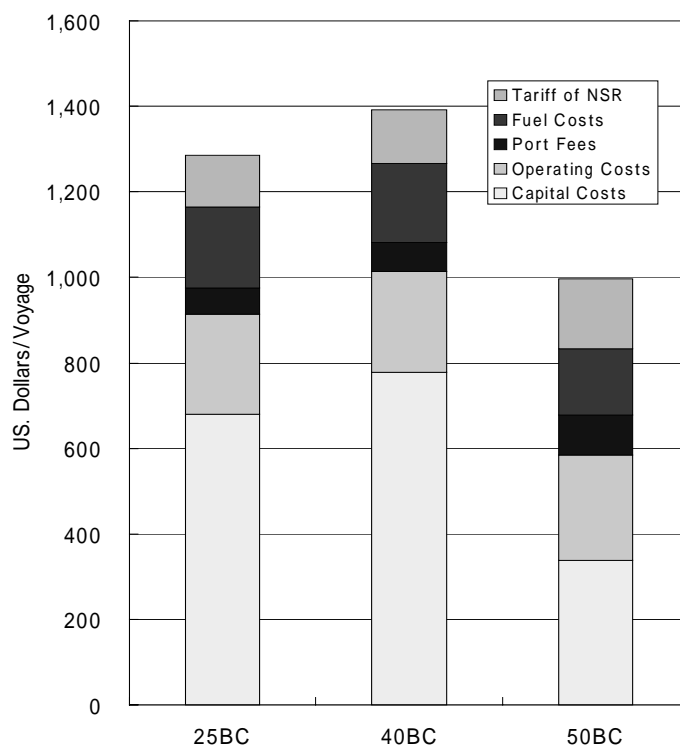

Figure C-8 Breakdown of average total operating cost per voyage (transit voyage)

Appendix

Table C-8 Breakdown of monthly average operating cost in regional routes

(Average values for 1957-1990) (Unit: 1,000US\$)

Month	Capital cost		Operating cost		Port fee		Fuel cost		Icebreaker fees, etc.		Total cost	
	East	West	East	West	East	West	East	West	East	West	East	West
1	258	451	89	156	49	37	98	82	114	118	607	844
2	287	459	99	158	49	37	110	51	112	120	656	825
3	290	465	100	160	49	37	103	50	112	120	653	832
4	290	448	100	154	49	37	100	47	112	120	650	807
5	279	412	96	142	49	37	88	55	112	118	623	763
6	242	386	83	133	49	37	59	51	112	117	545	723
7	225	412	78	142	49	37	53	79	74	120	479	790
8	215	354	74	122	49	37	43	101	77	116	457	729
9	214	344	74	119	49	37	43	90	7	116	457	704
10	219	369	75	127	49	37	49	111	74	116	467	760
11	222	433	76	149	49	37	54	166	111	113	512	898
12	243	438	84	151	49	37	88	128	111	115	575	868
Average	249	414	86	143	49	34	74	84	100	117	557	795

West: Regional west route

East: Regional east route

Table C-9 Principal dimensions of normal handy-size bulkers and operating costs

Particulars
Length: 180m
Length between perpendiculars: 173m
Width: 32.2m
Depth: 16.5m
Draft: 11.73m
Number of cargo holds: 5

Ship type	50BC
DWT (ton)	50,900
Gross tonnage (GT)	28,000
Gargo tonnage (t)	47,000
Ship speed (knot)	15.0
Power NSO(PS)	11,000
M/E FOC (t/day)	35.72
D/G FOC (t/day)	1.54
D/G FOC in port (t/day)	3.08
Ship price (k\$)	22,000
Voyage distance (NM)	11,588
Voyage days (including port and canal)	39.19
Voyage days	32.19
Anchorage day (day/voyage)	6
Suez canal transit day	1
Number of voyage	9.31
Annual cost (k\$)	7,913
Capital cost (k\$/year)	2,488
Maintenance fee (k\$/year)	560
Insurance (k\$/year)	1,599
Fuel cost (k\$/year)	1,032
Port cost (k\$/year)	805
SUEZ canal transit tolls (k\$)	1,295
Total cargo tonnage (ton/year)	437,752
Freight cost (\$/ton)	18.1
Cost per one-voyage (k\$)	850

Supplementary data on sea speed

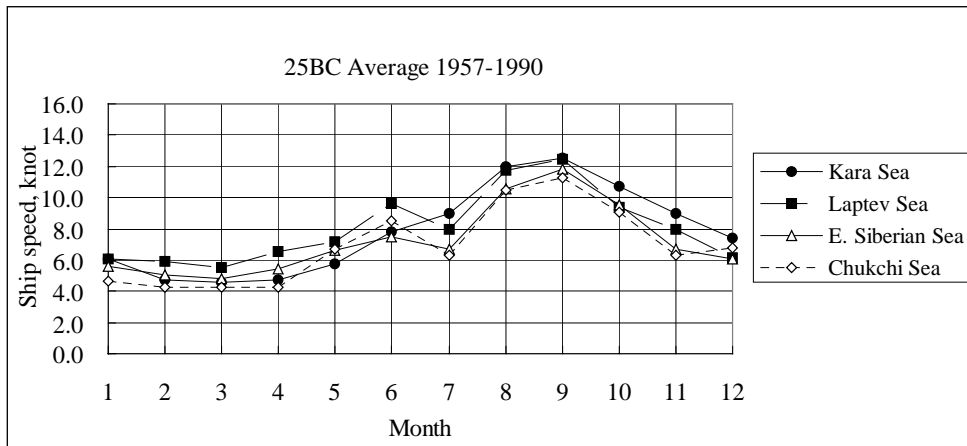

Figure C-9 Monthly changes in average sea speed of the 25BC in each sea region (averages for 1957-1990)

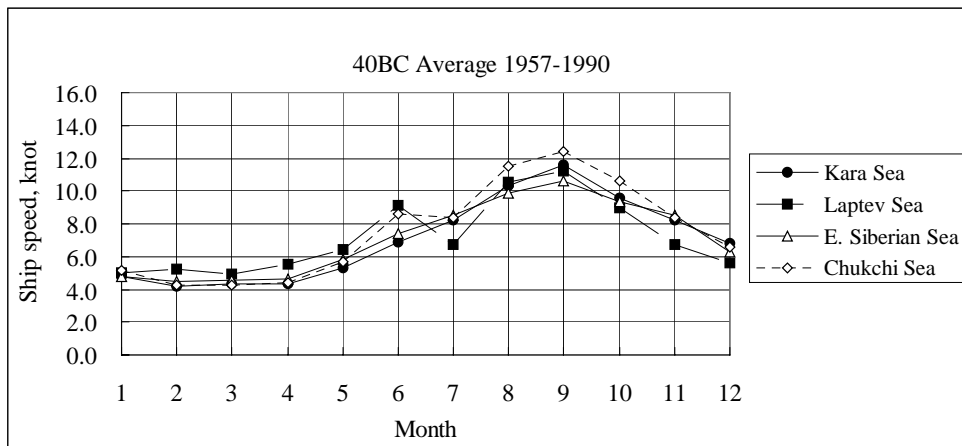

Figure C-10 Monthly changes in average sea speed of the 40BC in each sea region (averages for 1957-1990)

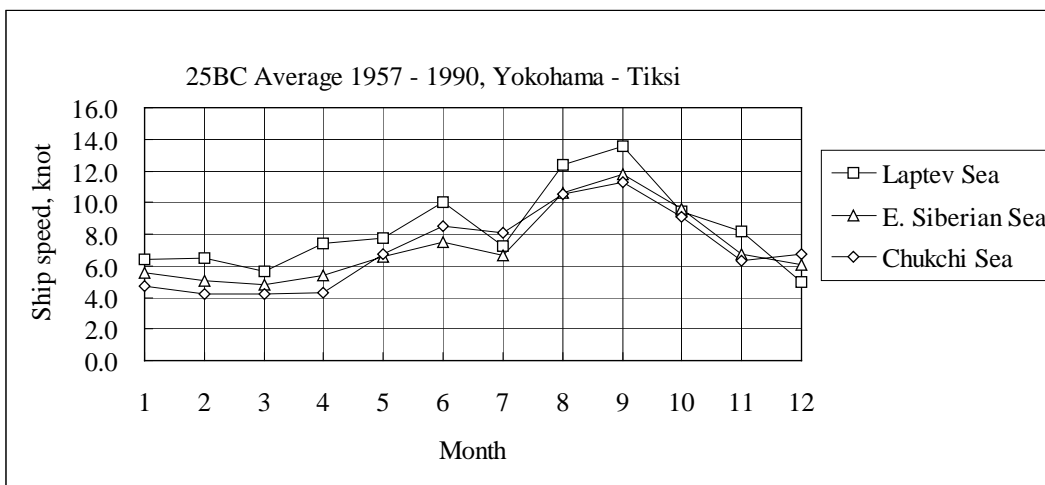

Figure C-11 Monthly changes in average sea speed in the regional east route in each sea region (25BC, averages for 1957-1990)

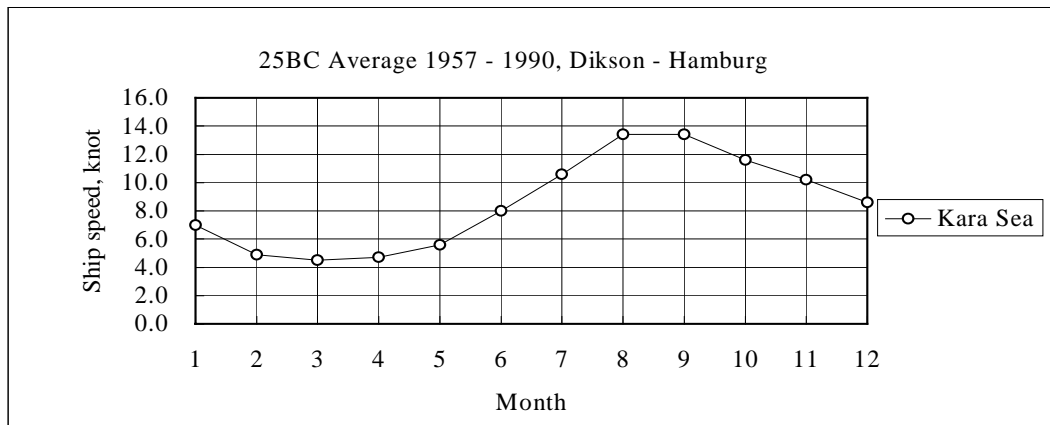

Figure C-12 Monthly changes in average sea speed in the regional west route in each sea region (25BC, averages for 1957-1990)

Supplementary discussion of the ships used in the simulation

40,000DWT icebreaking bulk/container ship

The design was aimed to enhance icebreaking capability for unescorted navigation for eight months in the NSR as well as dead weight up to 40,000DWT. Figure C-13 shows the general arrangement and rough body plan of such a vessel. This ship, as an open bulker, is capable of carrying either bulk or container cargo. To carry a container cargo, hatches are opened to store 825TEU of containers in the hold and 846TEU on the deck for a total container cargo capacity of 1671TEU. The propulsion system consists of two Azipods. The Azipod was successfully adopted in the icebreaking tanker Lunni. Propulsion is provided by two full rotating Azipod-units podded synchronous AC motors rating 14 MW, 28 MW in total. Four medium-speed engines rating 7.92MW each generate the AC electricity. The motors are controlled by cycloconverters. In the relatively gentle first-year ice, the bow and stern are reversed, the ship moves stern-first and the propeller pulls the ship forward, performing icebreaking in a mode of operation called stern mode. Like the bow, the stern is also designed to be effective at icebreaking. Because the Azipods can be rotated 360 °, a rudder is not needed, and the vessel boasts outstanding turning ability. The astern mode is usually employed up to moderate ice conditions without multi-year ice to preclude hard multi-year fragments from hitting against the Azipods, which are unable to bear high ice loads. When the ship encounters harsh multi-year ice, the bow turns forward to propel the ship in the conventional bow mode. When a ship is expected to encounter only moderate first-year ice, the bulbous bow design can be adopted, providing excellent performance in calm water. Ships designed in this fashion are called Double-acting Azipod Ships (DAS). However, this could not be done for NSR navigation, since multi-year ice is abundant in the eastern part of the NSR. The icebreaking capability of the ship was verified by model tests in ice tank. In stern mode the ship can move at 1m/s through level ice 1.8m thick, and in bow mode it can move at the same speed through level ice 1.2m thick. The vessel adopts stern mode to pass through ridges, by operation of Azipod, turning left and right to wash out broken fragments of the ridge keel, away from the surrounding of the ship. This action also reduces pressure at the bottom of the ridge, causing the ridge to sink downward and keeping the ship moving steadily forward. The ship was verified by model tests to be able to pass through a first-year ridge, equivalent to a ridge with 15-20m keel in full scale. In normal bow mode, the ship had to ram three times to pass through the ridge with keel 15m deep. In calm water the ship operates with only two generators (four in ice). Given output of 15.8MW and a sea margin of 15%, the ship's speed under these conditions is 14.5knots.

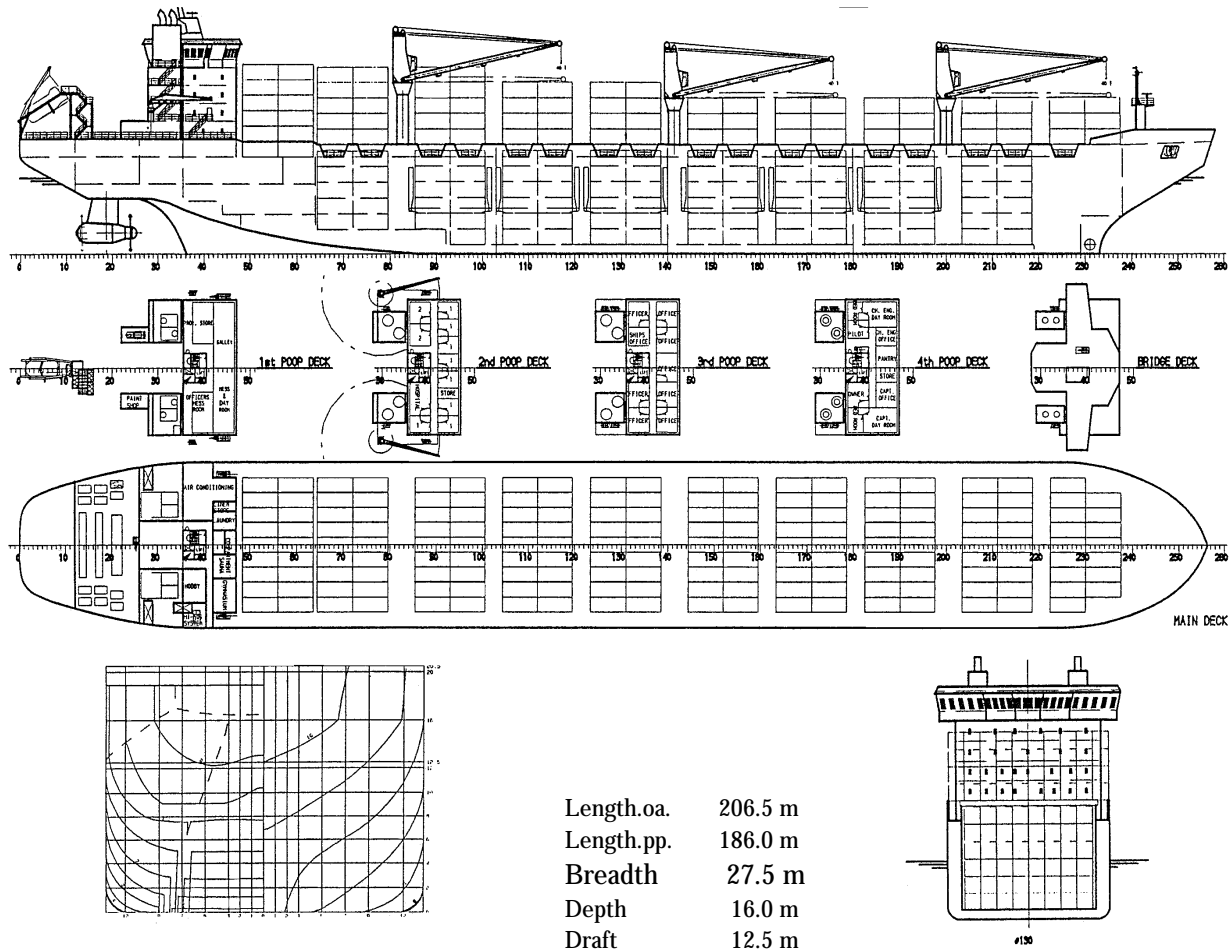
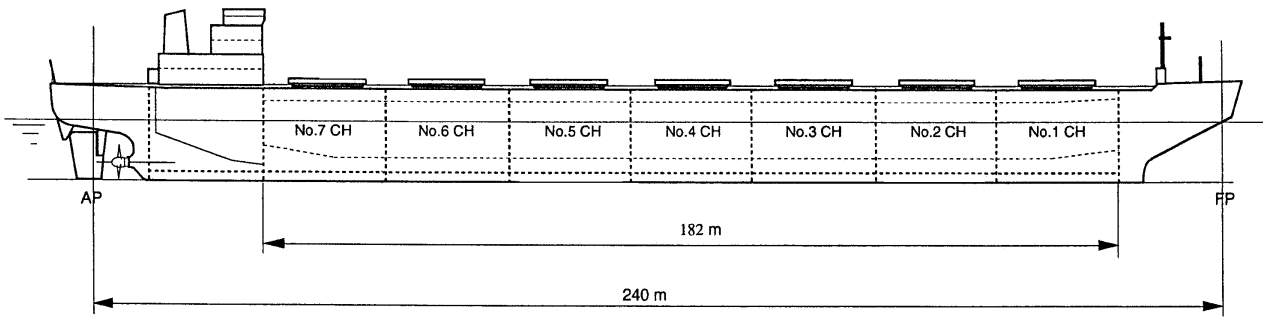

Figure C-13 General arrangement and rough body plan of the 40,000DWT icebreaking bulk/container ship (40BC)

50,000DWT icebreaking bulk carrier (50BC)

This design study was carried out by the SOF as JANSROP to improve capabilities of the vessel to be employed in the NSR, particularly from economic viewpoints. During fiscal years 1993 to 1995 the JANSROP focused on creating the best possible ship with the requirements of a draft of 8m and displacement of 27,000t. As the first step, combinations of three typical bows with two stern forms were examined and a series of model tests were conducted in ice tanks and conventional towing tanks. Based on the results of those tests, in 1997 a 50,000DWT icebreaking bulk carrier was developed, with draft expanded to 12.5m for operation in the northerly route. Based on the tank test results, a new bow, labeled bow D was adopted, combined the advantages of bow A, which provided excellent performance in calm water, and the spoon bow B, which delivered superior icebreaking performance. The stern form d was based on stern b but improved with the adoption of more inclined flare for better turning ability (Figure 4.1-17). By inference from the test results, the 50BC will be capable of speeds of 3 knots in level ice 1.2m thick. Given a sea margin of 15%, it will attain to normal speeds of 17 knots in calm water. Whereas the focus of the 40,000DWT icebreaking bulk/container carrier was its icebreaking capability, the emphasis in the 50BC is performance on calm water; the engine output was determined mainly by the power requirements in calm water. The propulsion power is provided by a fixed-pitch propeller connected directly with the main engine. Figure C-14 shows the general layout of the 50BC.

Appendix



Principal Particulars for
50,000 DWT Icebreaking Bulk Carrier

Length O.A.	252.2m
Length F.P.	240.0m
Breadth	30.0m
Depth	18.8m
Draft	12.5m
Block Coefficient	0.767
Displacement	70,900MT
Dead Weight	50,900MT
Cargo Capacity	abt. 70,000M3
Velocity in open water	17.0 knots at NSO with 15% S.M.
Velocity in level ice	3 knots in 1.2m thick level ice
Engine power, MCO	18.02 MW
Engine power, NSO	16.21 MW, 90% MCO
Propeller	7.1m Dia. x 1 (Fixed)

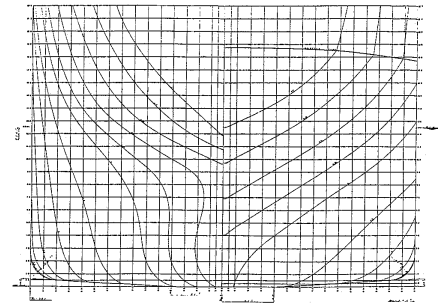
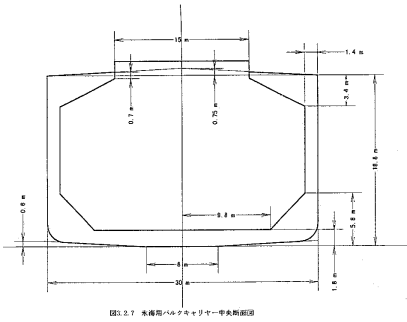

Figure C-14 General arrangement of the 50,000DWT icebreaking bulk carrier (50BC)

Appendix D

1. Brief Russia History (after 16th century)

1598	Fall of the Rurik dynasty. Boris Godunov elected Tsar.
1610	Polish army occupies Moscow
1611	Swedish army occupies Novgorod
1613	Council of All Russia elects Mikhail Romanov Tsar
1618	Russia makes peace with Sweden and attacks Poland
1649	Meeting of Imperial Assembly and promulgation of a Code of Law (formalization of serfdom)
1670	Revolt of Stenka Razin
1682	Ivan V and Peter I are proclaimed joint czars
1703	St. Petersburg is founded
1755	Moscow University is constructed
1760	Russian army occupies Berlin
1768	War against the Turks
1772	First partition of Poland
1812	Napoleon invades Russia
1825	Accession of Nikolai I ,Decembrist Uprising
1830	Polish rebellion
1853	War against the Turks (Crimean War begins)
1855	Peace treaty concluded between Russia and Japan
1856	Treaty of Paris
1861	Proclamation of the dissolution of serfdom, peasant rebellions, strife at the university
1875	Conclusion of a treaty between Japan and Russia exchanging the Kuril Islands for Sakhalin
1891	Start of May Day. Work begins on the Trans-Siberian Railway.
1895	Lenin forms the Workers' League for Class Struggle
1896	First congress of the Russian Socialist Party
1903	Split between the Bolsheviks and the Mensheviks
1904	Start of Russia-Japanese War
1905	Bloody Sunday. Treaty of Portsmouth. Moscow insurrection
1914	First World War breaks out
1917	February Revolution, Imperial rule in Russia crumbles
1922	Stalin assumes post of Secretary General
1939	Secret pact between Germany and Russia. Second World War begins. War between Soviet Union and Finland
1941	Japan and Russia sign neutrality pact. United states assists Soviet Union by supplying weapons. Japan bombs Pearl Harbor.
1945	Yalta Conference. Germany and Japan surrender.
1953	Stalin dies. Khrushchev becomes first secretary
1955	Warsaw Pact is signed
1964	Brezhnev becomes first secretary
1982	Brezhnev dies
1985	Gorbachev becomes secretary
1987	Gorbachev declares the NSR open
1990	Multi-party politics and private ownership of property are approved. Gorbachev is elected president. Baltic states become independent
1991	Yeltsin is elected president
1993	Russia adopts a new constitution
1997	Russia and Belarus sign a treaty of federation
1998	Economic and financial crisis

2. Administrative Units in the Russian Federation

Republics
Adygea, Altay, Bashkortostan, Buryatia, Dagestan, Ingush, Kabardino-Balkaria, Kalmykia, Karachay-Cherkessia, Karelia, Komi, Mari El, Mordovia, Sakha, North Ossetia, Tatarstan, Tyva, Udmurtia, Khakassia, Chechnya, Chuvashia, Yudaya
Autonomous state
Yudaya
Autonomous Okrug
Aga Buryatia, Komi Permyakia, Koryakia, Nenetsia, Taymyria, Ust'-Orda, Khantia-Mansia, Chukotka, Evenkia, Yamalia
Oblast (provinces)
Arkhangelsk, Vologda, Murmansk, Leningrad, Novgorod, Pskov, Bryansk, Vladimir, Kostomuksha, Moscow, Oriole, Ryazan, Tver, Smolensk, Tula, Yaroslavl, Ivanovo, Kaluga, Nizhny Novgorod, Kirovsk, Belgorod, Voronezh, Kursk, Ribek, Tanpov, Astrakhan, Volgograd, Penza, Samara, Saratov, Ulyanovsk, Rostov-na-Donu, Kulgansk, Olemburg, Perm', Sverdlovsk, Chelyabinsk, Novosibirsk, Omsk, Tomsk, Tyumen, Irkutsk, Chita, Amur, Kamchatska, Magadan, Sakhalin, Kaliningrad, Kemerovsk
Kray (territories)
Krasnodar, Stavropol, Altai, Khabarovsk, Primorsk
Federal cities
Moscow, St. Petersburg

3. CIS States Other Than Russia

(From source data 1995-1997)

Ukraine -----

Area : 603,700km²
 Capital : Kiev
 Population : 50.5 million
 Ethnic groups : Ukrainian (72.7%), Russian (22.0%), Jewish (0.9%), Belarussian (0.9%)
 Major industries : Agriculture, steelmaking, shipbuilding
 GNP : US\$84 billion
 Key phrases : Birthplace of Russia; grain belt of Russia; collapse of Soviet Union provided the opportunity for independence; dependence on Russia for energy

Republic of Belarus-----

Area : 207,600km²
 Capital : Minsk
 Population : 10.25 million
 Ethnic groups : Belarussian (77.9%), Russian (13.2%), Polish (4.1%), Ukrainian (2.9%), Jewish (1.1%)
 Major industries : Machine industries, electronics, synthetic fibers, fertilizer, foodstuffs
 GNP : US\$21.4 billion
 Key phrases : Eastern Slavic ethnic group, economic potential, slow pace of economic reform

Republic of Moldova-----

Area : 33,700km²
 Capital : Chisinau
 Population : 4.24 million
 Ethnic groups : Moldavian (Romanian) (64.5%), Ukrainian (13.8%), Russian (13.0%), Gagaus (3.5%), Bulgarian (2.0%)
 Major industries : Machine industries, agriculture, food processing
 GNP : US\$4.3 billion
 Key phrases : Rule by Ottoman Turks, fertile country, slow pace of economic reform

Republic of Uzbekistan -----

Area : 447,400km²
 Capital : Tashkent
 Population : 23.87 million
 Ethnic groups : Uzbek (75.8%), Russian (6.0%), Tadjik (4.8%), Kazakh (4.1%), Tatar (1.6%)
 Major industries : Cotton, mining
 GNP : US\$23.49 billion
 Key phrases : Kizilkum-karakum Desert, Timur Empire, cotton exports

Republic of Kazakhstan-----

Area : 2,717,300km²

Appendix

Capital : Astana (formerly Akmola)
Population : 15.8 million
Ethnic groups : Kazakh (45.9%), Russian (34.8%), Ukrainian (4.9%), German (3.2%), Uzbek (2.3%)
Major industries : Heavy industry, agriculture, metallurgy, metals
GNP : US\$22.1 billion
Key phrases : Rich in mineral resources, second largest in CIS in land area after Russia, former laboratory in Semipalatinsk

Turkmenistan -----

Area : 488,100km²
Capital : Ashkhabad
Population : 4.69 million
Ethnic groups : Turkmen (73.3%), Russian (9.8%), Uzbek (9.0%), Kazakh (2.0%)
Major industries : Energy, cotton
GNP : US\$4.13 billion
Key phrases : Permanently neutral country, natural gas

Kyrgyz Republic -----

Area : 198,500km²
Capital : Bishkek (formerly Frunze??)
Population : 4.67 million
Ethnic groups : Kyrgyz (52.4%), Russian (21.5%), Uzbek (12.9%), Ukrainian (2.5%), German (2.4%)
Major industries : Agriculture, animal husbandry, mining
GNP : US\$3.16 billion
Key phrases : Mountainous terrain, mines

Republic of Tadjikistan -----

Area : 143,100km²
Capital : Dushanbe
Population : 6.07 million
Ethnic groups : Tadjik (64.9%), Uzbek (25.0%), Russian (3.5%)
Major industries : Cotton, fruit, animal husbandry
GNP : US\$1.97 billion
Key phrases : Mountainous terrain (Pamyr plateau), political instability

Azerbaijan Republic -----

Area : 86,600 km²
Capital : Baku
Population : 7.63 million
Ethnic groups : Azeri (82.7%), Russian (5.6%), Armenian (5.6%)
Major industries : Oil, agriculture
GNP : US\$3.67 billion
Key phrases : Oil resources, Silk Road, ethnic strife

Republic of Georgia -----

Area : 69,700 km²
Capital : Tbilisi
Population : 5.68 million
Ethnic groups : Georgian (70.1%), Armenian (8.1%), Russian (6.3%), Azeri (5.7%), Osseti (5.0%)
Major industries : Animal husbandry, agriculture
GNP : US\$2.35 billion
Key phrases : Native land of Stalin, fruit, tea

Republic of Armenia -----

Area : 29,800km²
Capital : Yerevan
Population : 3.79 million
Ethnic groups : Armenian (93.3%), Azeri (2.6%), Kurdish (1.7%)
Major industries : Agriculture
GNP : US\$2.39 billion
Key phrases : Smallest in area, historic, cognac

Boundary of the CIS

The Commonwealth of Independent States (CIS)

4. Main Governmental Organizations of the Russian Federation (in 1998)

The Russian Republic consists of 89 administrative units. These comprise 49 oblasts, six krais, 21 autonomous republics, one autonomous oblast, 10 autonomous okrugs and two federal cities. In the Russian constitution, power is distributed among the central government and individual regional governments. The regional governments have their own powers, which cannot be unilaterally altered by the central government. This system preserves the unique character of each of the nation's regions. The main administrative units-oblasts, krais and so forth-are state organs, while national authority is invested in the federation. Unlike the United States, which is a federation of states of equal status, the Russian Federation is a heterogeneous confederation of bodies of different type and status. The main divisions of Russia were established in 1868, with the krai established as frontier areas with their own subdivisions based on ethnicity. In one case, a Jewish autonomous oblast was separated from Khabarovsk Krai and is now sometimes called a krai itself. According to Article 5 of the Russian Constitution, each of the oblasts, krais, autonomous republics, autonomous oblast and federal cities is on a level footing with the others. In the federal treaty of March 1992, powers were assigned between the Federation and autonomous republics, between the Federation and krai and between the Federation and oblasts. However, some republics have asserted that their own laws have precedence over those of the Federation, further complicating the relationship between the center and the regional governments.

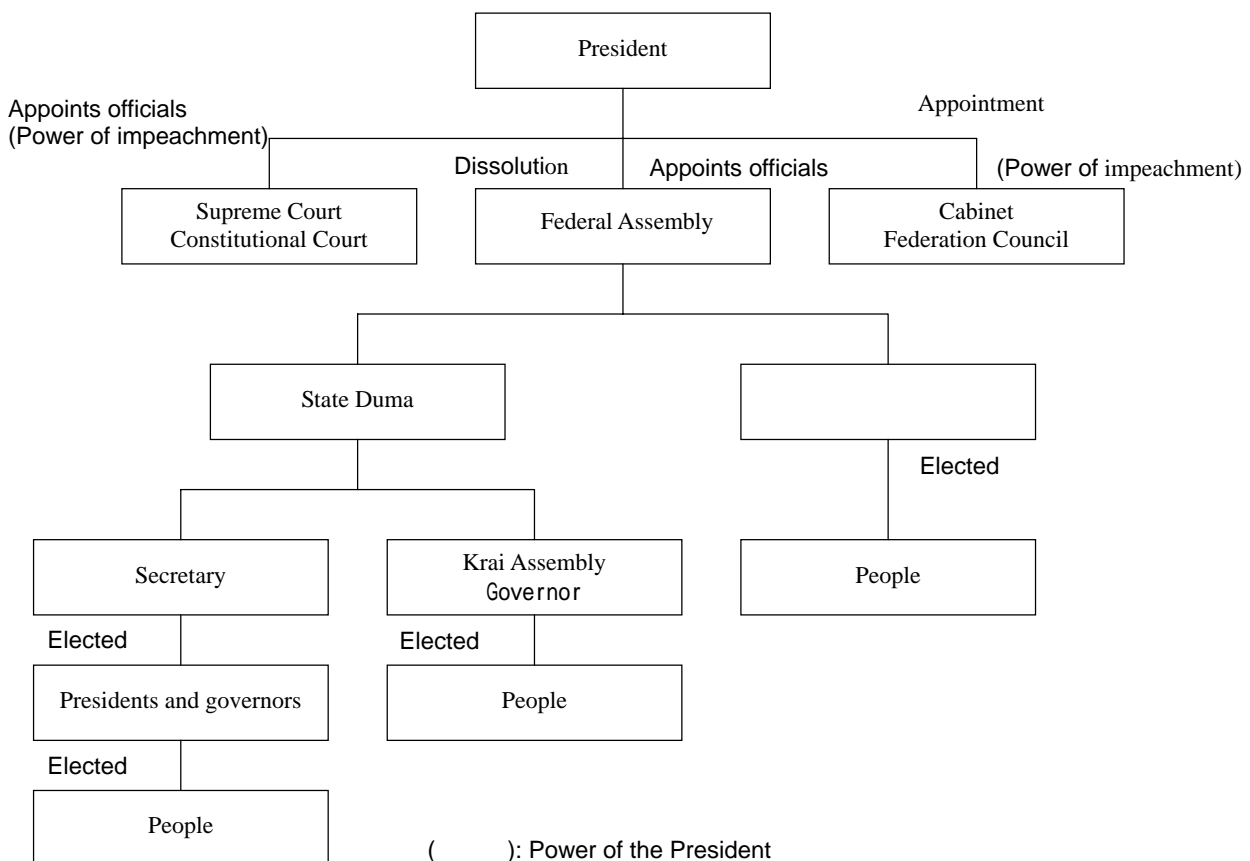

Political structure of the Russian Federation

Appendix E: List of INSROP WORKING PAPERS

- WP- 1
Marine Insurance for the NSR. Pilot Study.
By D.L. Torrens, July 94.
- WP- 2
Routing Communication and IT-Customizing.
By N. Kjerstad, Aug. 94.
- WP- 3
Ice Monitoring by Non-Russian Satellite Data.
Phase 1. Feasibility Study.
By S. Sandven & K. Kloster, Aug. 94.
- WP- 4
Design and Development of Information System.
By S.M. Løvås, C. Smith & K.A. Moe, Aug. 94.
- WP- 5
Content of Database, Planning and Risk
Assessment.
By S. Løset & S. Vefsnmo, Oct. 94.
- WP- 6
Oil Spreading on the Snow/Ice Surface.
By S. Ovsienko, S. Zatsupa & A. Ivchenko, Jan. 95.
- WP- 7
Ice Flaking Tests Conducted with a Gas Actuator
System.
By S.J. Jones, R.E. Gagnon, D. Masterson & P.
Spencer, Jan. 95.
- WP- 8
Oil Product Export from North West Russia.
By T.R. Ramsland, Jan. 95
- WP- 9
Initial Survey of Russian Data Sources.
By M. Gavrilov & B. Sirenko, Apr. 95.
- WP- 10
Operational Tools.
By Z. Gudkovich et al, May 95.
- WP- 11
Assessment of Potential Cargo from and to Europe
via the NSR.
By Ø. Andersen, T.J. Heggeli & T. Wergeland, May
95.
- WP- 12
Linkages and Impact Hypothesis concerning the
Valued Ecosystem Components (VEC's)
Invertebrates, Fish, the Coastal Zone and Large
River Estuaries and Deltas.
By L.H. Larsen, A. Evenset & B. Sirenko, June 95.
- WP- 13
The NSR in the Context of Arctic Military and
Ecological (Environmental) Security.
By A.Y. Roginko, June 95.
- WP- 14
Routing, Communication and IT-Customizing.
Volume 2.
By N. Kjerstad, July 95.
- WP- 15
The Potential of the Northern Sea Route for a
Regular Cargo Service.
By B. Buchan, Aug. 95.
- WP- 16
The Northern Sea Route and Possible Regional
Consequences.
By S. Høifødt, V. Nygaard & M. Aanesen, Aug. 95.
- WP- 17
Operational Aspects (Volume 1).
By A. Baskin, A. Buzuyev, Y. Yakshevich et al, Sept.
95.
- WP- 18
Northern Sea Route Social Impact Assessment:
Indigenous Peoples and Development in the Lower
Yenisei Valley.
By D.G. Anderson, Sept. 95.
- WP- 19
The Significance of the NSR for Regional
Development in Arctic Areas of Russia.
By A.G. Granberg, Oct. 95.
- WP- 20
The Northern Sea Route. Conditions for Sailing
according to European Community Legislation -
with Special Emphasis on Port State Jurisdiction.
By P. Ørebech, Nov. 95.

Appendix

- WP- 21
New Concepts of Removing Ice: Patent Search, Generalization and Analysis of Existing of Russian Inventions.
By A.V. Ierusalimsky et al, Oct. 95.
- WP- 22
Development of Oil and Gas Exports from Northern Russia.
By A. Backlund, Nov. 95.
- WP- 23
Planning and Risk Assessment. Volume 1 - 1993 project work.
By A. Brovin, L. Tsoy et al, Nov. 95.
- WP- 24
Operational Information on Nature Conditions. Volume 1 - 1993 project work.
By E. Makarov et al, Dec. 95.
- WP- 25
Design of Information System. Volume 1 - 1993 project work.
By V. Grishchenko, E. Yakshevitch et al, Dec. 95.
- WP- 26
Content of Database. Volume 1 - 1993 project work.
By A. Baskin, L. Tsoy, S. Brestkin et al, Dec. 95.
- WP- 27
Northern Sea Route Freight Operations: Survey of Logistic Modelling.
By S.I. Heimdal, Dec. 95.
- WP- 28
Historical and Current Uses of the Northern Sea Route: Part 1.
By T. Armstrong, Jan. 96.
- WP- 29
Perspective Research. Volume 1 - 1993 project work.
By V. Zacharov, A. Baskin et al, Jan. 96.
- WP- 30
Requirements for Ice Performance of Large Ships with Shallow Draft.
By L. Tsoy, Jan. 96.
- WP- 31
The Adaptive Environmental Assessment and Management AEAM in INSROP - Impact Assessment Design.
By J. Thomassen, S.M. Løvås & S. Vefsnmo, Jan. 96.
- WP- 32
Evaluation of the Northern Sea Route Using the Ice Regime Shipping Control System.
By D.L. Hagen & S.J. Jones, Jan. 96.
- WP- 33
Impacts of Transportation Systems on the Communities of Western Alaska: Analysis of the Literature.
By N.E. Flanders, Jan. 96.
- WP- 34
Planning and Risk Assessment. Volume 2-1994 project work.
By A.Brovin, L. Tsoy et al, Jan. 96.
- WP- 35
Content of Database, Planning and Risk Assessment. Volume 2 - 1994 project work.
By S. Vefsnmo, S.M. Lovas, A. Backlund & E. Ranki, Feb. 96.
- WP- 36
Operational Tools. Volume 2 - 1994 project work.
By Z. Gudkovich, I.D. Karelin et al, Feb. 96.
- WP- 37
The Legal Status of the Russian Baselines in the Arctic.
By R.D. Brubaker, Feb. 96.
- WP- 38
Ice Monitoring by non-Russian Satellite Data. Phase 2: Pilot Demonstration.
By O.M. Johannesen, S.Sandven, K.Kloster, V.V. Melentyev & L. Bobylev, Feb. 96.
- WP- 39
Influence of Ice Compression on Feasible Navigation on the Northern Sea Route.
By T. Heideman, Mar. 96.
- WP- 40
Selection of Marine Mammal Valued Ecosystem Components and Description of Impact Hypotheses in the Northern Sea Route Area.
By O. Wiig, S.E. Belikov, A.N. Boltunov & G.W. Garner, Mar. 96.

- WP- 41
European Gas Markets and Russian LNG. Prospects for the Development of European Gas Markets and Model Simulations of Possible New LNG Supplies from Year 2000.
By T. Eldegard, Mar. 96.
- WP- 42
Content of Database. Volume 2 - 1994 Project Work.
By Loly Tsoy, A. Baskin, S. Brestkin et al, Mar. 96.
- WP- 43
Behaviour of Ice Floe in Restricted Waters.
By H. Yamaguchi, Apr. 96.
- WP- 44
The Northern Sea Route and the Rivers Ob-Irtysh and Yenisey.
By T.R. Ramsland, Apr. 96.
- WP- 45
Variability Analysis of Natural Conditions and Influence on NSR Sailing.
By S. Vefsno & S.M. Lovas, Apr. 96.
- WP- 46
Marine Insurance for the NSR: Towards a New Risk Regime?
By E. Gold, J.A. Cantello & P.L. Wright, Apr. 96.
- WP- 47
INSROP GIS v1.10a - User's Guide and System Documentation.
By S.M. Løvås & O.W. Brude, May 96.
- WP- 48
Marine Transportation of Oil from Timan Pechora and from Inland Russian Fields.
By D. Andresen & A. Backlund, May 96.
- WP- 49
Influence of the Northern Sea Route on Social and Cultural Development on Indigenous Peoples of the Arctic Zone of the Sakha Republic (Yakutia).
By S.I. Boyakova, V.N. Ivanov, G. Osherenko, L.I. Vinokurova, B.V. Ivanov, T.S. Ivanova, B.V. Ignatiyeva, S.P. Kistenev, & D.A. Shirina, May 96.
- WP- 50
Seagoing Logistics Solutions to Oilfield Material Supplies.
By T. Wood & R. Martin, June 96.
- WP- 51
Indigenous Peoples and Development in the Chukchi Autonomous Okrug.
By D.L. Schindler, July 96.
- WP- 52
Jurisdiction Governing the Straits in Russian Arctic Waters.
By R.D. Brubaker, July 96.
- WP- 53
The Marine Invertebrates, Fish and Coastal Zone Features of the NSR Area.
By L.H. Larsen, R. Palerud, H. Goodwin & B. Sirenko, Aug. 96.
- WP- 54
Selected Issues on Regional Economic Development along the Northern Sea Route.
By S. Høifødt, V. Nygaard, M. Aanesen & G.B. Hønneland, Aug. 96.
- WP- 55
Survey of Logistics Models. Part 2: The Methodology of Simulative Modelling of Transport and Ice Breaker Fleets Operations in the Arctic.
By A. Schelkanov & Y. Kelberg, Aug. 96.
- WP- 56
West Siberian Oil and the Northern Sea Route: Current Situation and Future Potential.
By V. Kryukov, A. Moe & V. Shmat, Sept. 96.
- WP- 57
The Legal Status of Straits in Russian Arctic Waters "Internationality. (Chapter 4)"
By R.D. Brubaker, Sept. 96.
- WP- 58
Regional Cooperation in Northeast Asia: New Opportunities for the Russian Arctic?
By H. Simonsen, Sept. 96.
- WP- 59
The NSR Transit Study (Part IV): The Economics of the NSR. A Feasibility Study of the Northern Sea Route as an Alternative to the International Shipping Market.
By T.R. Ramsland & S. Hedels, Sept. 96.
- WP- 60
Selection of Marine Bird Valued Ecosystem Components and Descriptions of Impact Hypothesis in the Northern Sea Route Area.

Appendix

By V. Bakken, M.V. Gavrilov, K. Isaksen & K.B. Strann, Sept. 96.

WP- 61

Historical and Current Uses of the Northern Sea Route. Part III: The period 1855-1917.

By J.P. Nielsen, Sept. 96.

WP- 62

New Concepts of Removing Ice. Investigation of the Efficiency and Advisability to Use Non-traditional Shape of Hull Lines for Icebreakers and Icebreaking Cargo Ships of Arctic Navigation.

By A.V. Ierusalimsky, S.M. Ponomarev & T.M. Semanova, Oct. 96.

WP- 63

Control of Pollution from Ships on the Northern Sea Route.

By G. Semanov, J. Kirsh, V. Karev, N. Sisemov & O. Zhuravlev, Oct. 96.

WP- 64

Requirements to NSR Shore Reception Facilities.

By G. Semanov, V. Molchanov, S. Lotukhov, A. Stepanov & L. Gagieva, Oct. 96.

WP- 65

NSR Shipboard Oil Pollution Emergency Plan.

By V. Somkin, D. Ilyscenko-Krylov & P. Lastochkin, Oct. 96.

WP- 66

Ice Environment and Ship Hull Loading along the NSR.

By M. Lensu, S. Heale, K. Riska & P. Kujala, Oct. 96.

W- 67

The Participation Rights under the World Trade Organization General Agreement on Trade in Services (GATS): The Case of International Northern Sea Route Shipping Transportation Services.

By P. Ørebech, Oct. 96

WP- 68

Content of Database.

By V. Vasilyev, L. Tsoy, Y. Glebko, L. Timofeeva, S. Brestkin, A. Buzuyev, Y. Gorbunov, S. Nikolayev, V. Porubayev, K. Teitelbaum, S. Frolov et.al, Nov. 96

WP- 69

Perspective Research (Vol 2.). Part I: Changes in Climate, Ice and Shipping Conditions along the NSR during the XXth Century. Part II: Accurate Positioning in the Arctic.

By V.F. Zakharov, A. Baskin, G.V. Alekseyev, A.Y. Buzuyev & S. Samonenko, Nov. 96.

WP- 70

Environmental and Structural Safety of Ships.

By L. Tsoy, V. Volkov, S. Karavanov, F. Moreynis & A. Zubkova, Nov. 96.

WP- 71

Operational Information on Nature Conditions (Volume 2).

By E. Makarov, N. Adamovich, A. Korzhikov, Y. Vanda, I. Karelin & A. Buzuyev, Dec. 96.

WP- 72

Freezing Damage to Northern Sea Route Cargo: Liability and Insurance Considerations.

By A. Fakhry, Dec. 96.

WP- 73

The Potential of the NSR with a Nuclear Icebreaking Container Ship.

By T. Takamasa, K. Kondo, K. Miyashita, S. Hayashi & I. Aya, Dec. 96.

WP- 74

Selected Studies in Regional Economic Development along the Northern Sea Route.

By A.G. Granberg, Jan. 97.

WP- 75

Political Aspects of International Shipping along the Northern Sea Route.

By A.N. Yakovlev, A.I. Arikainen, O.A. Kossov & A.P. Ushakov, Jan. 97.

WP- 76

Coastal Pollution Emergency Plan. Part I.

By G. Semanov, V. Volkov, V. Somkin & D. Iljushenko-Krylov, Feb. 97.

WP- 77

Northern Gas Fields and NGH Technology - A Feasibility Study to Develop Natural Gas Hydrate Technology for the International Gas Markets.

By T.R. Ramsland, E.F. Loy & S. Døsen, April 97.

- WP- 78
Experimental Study to Separate into Components the Interaction Force between Propeller and Ice Piece.
By K. Tamura & H. Yamaguchi, May 97.
- WP- 79
Environmental Regulation in the Russian Arctic. By R.D. Brubaker, May 97.
- WP- 80
Design of Information System.
By V. Grishchenko, E. Yakshevitch, O. Deviatayev, Yu. Shcherbakov, V. Smirnov & A. Shigabutdinov, May 97.
- WP- 81
Navigating the Straits of the Northern Sea Route.
By G.B. Hppneland, June 97.
- WP- 82
Improvement of Information Support to Navigation along the NSR.
By A. Baskin, V. Vasilyev, S. Samonenko, V. Isakov & E. Danilov, June 97.
- WP- 83
National Security and International Environmental Cooperation in the Arctic - the Case of the Northern Sea Route.
By W. Østreng (ed.), F. Griffiths, R. Vartanov, A. Roginko & V. Kolossov, July 97.
- WP- 84
Historical and Current Uses of the Northern Sea Route. Part IV: The Administration of the Northern Sea Route (1917-1991).
By V. Bulatov, Aug. 97.
- WP- 85
Marine Insurance for the Northern Sea Route: The Feasibility of a New Risk Regime. Some Initial Conclusions.
By E. Gold, J.A. Cantello & P.L. Wright, Aug. 97.
- WP- 86
Seaborne Exports of Gas from Yamal.
By N.A. Isakov, E.G. Logvinovich, F.A. Moreynis, A.E. Nikulin, N.V. Popovich, A.N. Silin, N.N. Stenin, I.L. Sverdlov & V.A. Erashov, Sept. 97.
- WP- 87
Regional Port Development along the NSR.
By N. Isakov, G. Serebryansky, A. Parfenov, T. Patrakova & N. Sadofieva, Sept. 97.
- WP- 88
Matters of Responsibility for Marine Pollution under the Legislation of the Russian Federation. (Review of the Main Legislative Acts).
By A.L. Kolodkin, O.V. Kulistikova & E.M. Mokhova, Sept. 97.
- WP- 89
Marine Oil Transportation from Timan Pechora and Inland Russian Fields.
By N. Isakov, A. Nikulin, N. Popovich & I. Sverdlov, Oct. 97.
- WP- 90
Indigenous Peoples of the Northern Part of the Russian Federation and their Environment. Atlas and Historical/Ethnographical Background Information.
By W.K. Dallmann, Oct. 97.
- WP- 91
Operational Aspects (Volume 2).
By A. Baskin, A. Buzuyev, Y. Yakshevich et al, Oct. 97.
- WP- 92
Russia and its NSR Neighbours in Northeast Asia and the Barents Region: A Comparative View of Relations and Perceptions.
By H. Simonsen, Nov. 97
- WP- 93
The Northern Sea Route and Native Peoples. Lessons from the 20th Century to the 21st.
By G. Osherenko, D. Schindler, A. Pika & D. Bogoyavlensky, Nov. 97
- WP- 94
Legal Regime of Navigation in the Russian Arctic.
By A.L. Kolodkin, V.Yu. Markov & A.P. Ushakov, Nov. 97.
- WP- 95
Using the INSROP Phase 1 Data in a Transport Evaluation Process.
By A. Backlund, E. Gold & J. Kivela, Jan. 98.
- WP- 96
Current Use of the NSR.
By Y. Ivanov, A. Ushakov & A. Yakovlev, Jan. 98

Appendix

WP- 97

Oil Vulnerability Assessment for Marine Birds occurring along the Northern Sea Route Area.

By M. Gavrilov, V. Bakken, L. Firsova, V. Kalyakin, V. Morozov, I. Pokrovskaya & K. Isaksen, Mar. 98

WP- 98

Marine Insurance for the Northern Sea Route.

By V. Musin, Mar. 98.

WP- 99

The NSR Dynamic Environmental Atlas.

By O.W. Brude, K.A.Moe, V. Bakken, R. Hansson, L.H. Larsen, J. Thomassen & Ø. Wiig, May 98.

WP- 100

The NSR in Japanese Views of Trade.

By K. Shikano & H. Kitagawa, May 98.

WP- 101

Operational Aspects. Volume 3 - 1995 project work.

By A. Baskin, A. Buzuyev, E. Yakshevich et al, Jun. 98.

WP- 102

Analysis and Evaluation of Economic Conditions of Energy Prospects Implementation of the Yamalo-Nenets Autonomous Okrug.

By V. Kryukov, A. Tokarev & V. Schmat, Jun. 98.

WP- 103

Some Aspects of Port and Harbour Management along the NSR.

By H. Kitagawa, K. Izumiyama & T. Ozeki, Jul. 98.

WP- 104

Environmental Safety of Nuclear Icebreakers.

By V. Pravdin, N. Tkachev, A. Levin & B. Levin, Jul. 98.

WP- 105

Some Aspects of Foreign Trade Regime of the Russian Federation and Co-operation in the Field of International Shipping.

By A.I. Frolov, M.S. Khanin & I.N. Mikhina, Aug. 98.

WP- 106

Russian Administration of the Northern Sea Route - Central or Regional?

By Y.M. Ivanov, A.P. Ushakov & A.N. Yakovlev, Aug. 98.

WP- 107

Collection of SA-15 Operations Data.

By L.G. Tsoy, S.B. Karavanov, Yu. V. Glebko et al, Aug. 98.

WP- 108

Routes and Associated Operational Infrastructure.

By A. Baskin, L. Egorov et al, Aug. 98.

WP- 109

An Overview of Russian Satellite Data for the Northern Sea Route.

By A. Bushuev, V. Loshilov, S. Sandven, V. Smirnov et al, Aug. 98.

WP- 110

Influence of Ice Compression on Feasible Navigation on the Northern Sea Route.

By K. Juurmaa, T. Heideman, A. Uuskallio, M. Patey & L. Kosomaa, Aug. 98.

WP- 111

Assessment of Social and Cultural Impact on Indigenous Peoples of Expanded Use of the Northern Sea Route.

By Z. Sokolova & A. Yakovlev, Sep. 98.

WP- 112

Indigenous Peoples and Development of the Yamal Peninsula.

By A. Golovnev, G. Osherenko, Yu. Pribylski & D. Schindler, Sep. 98.

WP- 113

Historical and Current Uses of the Northern Sea Route. Part II: The Period 1745-1855.

By E. Okhuizen, Sep. 98.

WP- 114

Large Scale Hull Loading of First-year Sea Ice.

By R. Gagnon, R. Frederking, S. Jones, P. Spencer & D. Masterson, Sep. 98.

WP- 115

Oil Spilling From Grounded Mid-deck Tanker.

By H. Tamama, Sep. 98.

WP- 116

The Future of Murmansk, Archangelsk and Other Western NSR Ports in a Regional Perspective.

By A. Brodin, Sep. 98.

- WP- 117
Economic Development in Northern Siberia and the Russian Far East: Implications for the Northern Sea Route.
By R. Castberg, A. Moe & A. Berteig, Sep. 98.
- WP- 118
The Distribution of Marine Mammals in the Northern Sea Route Area.
By S. Belikov, A. Boltunov, T. Belikova, T. Belevich & Y. Gorbunov, Oct. 98.
- WP- 119
Requirements to Environmental and Structural Safety of Ships.
By F. Moreynis, V. Likhomanov, S. Karavanov et al, Oct. 98.
- WP- 120
Design of the NSR Service Ships. Model Tests in Ice with M-224. Design of 40 000 and 25 000 dwt Ice Breaking Bulk / Container Carrier.
By Ann-Cristin Forsen, Jari Kivela & Erkki Ranki, Nov. 98.
- WP- 121
National Conditions along the Selected Routes.
By S. Brestkin, A. Yulin, V. Karklin, I. Ashik, Z. Gudkovich, I. Karelin, S. Klyachkin, E. Makarov, E. Sapershtein, I. Sergeeva, V. Smolyanitsky, K. Teitelbaum & S. Frolov, Nov. 98.
- WP- 122
Navigational Safety Management System of the NSR. Part 1: ISM Code Implementation in the Russian Arctic. Part 2: Satellite Communication Used for Safety Management of NSR Navigation.
By V. Vasilyev, E. Yakshevich, A. Baskin & A. Shigabutdinov, Dec. 98.
- WP- 123
The Distribution, Population Status and Ecology of Marine Birds Selected as Valued Ecosystem Components in the Northern Sea Route Area. Edited by M. Gavrilov, V. Bakken & K. Isaksen, Dec. 98.
- WP- 124
Shipping and Marine Insurance on the Northern Sea Route: Conclusions 1993-1998.
By E. Gold, J.A. Cantello & P.L. Wright, Jan. 99.
- WP- 125
Prediction of Ice Conditions along the NSR Using Satellite Data.
By C.K. Rheem & H. Yamaguchi, Jan. 99.
- WP- 126
Environmental Conditions Affecting Commercial Shipping on the Northern Sea Route.
By A.Yu. Proshutinsky, T. Proshutinsky & T. Weingartner, Jan. 99.
- WP- 127
Hydrometeorological and Navigational Support for NSR Navigation.
By V.D. Grishchenko, V.G. Smirnov, O.S. Deviatayev, Yu.A. Shcherbakov & S.V. Kovachev, Jan. 99.
- WP- 128
Legal and Environmental Evaluation of the Routes Selected for the INSROP Simulation Study.
By A. Yakovlev, G. Semanov, K.A. Moe et al, Jan. 99.
- WP- 129
Oil Spill Contingency Plan.
By G.N. Semanov, Y.B. Kirsh and O.B. Grachova, Jan. 99.
- WP- 130
Analysis and Evaluation of Economic Conditions of Energy Prospects Implementation in the Yamalo-Nenets Autonomous Okrug. Part II: Comparative Analysis of Taxation Schemes Potentially Applicable in the YaNAO Hydrocarbon Reserves.
By V.A. Kryukov, A.N. Tokarev and V.V. Schmat, Jan. 99.
- WP- 131
Development of the Databases on Natural Conditions of Navigation along the NSR.
By S. Brestkin, V. Karklin, V. Bokov, Yu. Gorbunov, I. Karelin, S. Losev, E. Makarov, I. Potekhin, I. Sergeeva and S. Frolov, Jan. 99.
- WP- 132
Russian Fertiliser Industry, Potential Cargo for the NSR.
By N. Isakov, I. Krupsky, M. Kostenko, L. Alekseeva, T. Maksimova and A. Nikulin, Jan. 99.
- WP- 133
Guide for Ship-generated Waste Management on the Northern Sea Route.
By G.N. Semanov, Y.B. Kirsh & O.B. Grachyova, Feb. 99.

Appendix

WP- 134

Practical Demonstration of Real-time RADARSAT SAR Data for Ice Navigation on the Northern Sea Route.

By S. Sandven, V. Alexandrov, Ø. Dalen, M. Lundhaug, V. Melentyev, V. Smirnov, N. Babich & K. Kloster, Feb. 99.

WP- 135

Cargo-forming Potential of Sakha (Yakutia), Chukot Autonomous District and Other Far-eastern Regions for the Northern Sea Route.

By A. Granberg, G. Kobylkovsky & V. Plaksin, Feb. 99.

WP- 136

Statistical Oil Spill Simulations for the Northern Sea Route.

By S. Vefsnmo, Feb. 99.

WP- 137

The Cargo Generating Potential of the Angaro-Yenisei Region for the Northern Sea Route.

By M.K. Bandman, V.V. Vorobieva, T.N. Yesikova, V.D. Ionova & B.V. Robinson, Feb. 99.

WP- 138

Organisational Forms of Shipowner Liability Insurance for The Northern Sea Route with Specific Reference to the Perspective of P&I Clubs in Russia.

By V. Musin, Feb. 99.

WP- 139

Potential Cargo Flow Analysis & Economic Evaluation for the Simulation Study.

By N. Isakov, A. Yakovlev, A. Nikulin, G. Serebryansky & T. Patrakova, Mar. 99.

WP- 140

Economic Evaluation of NSR Commercial Shipping.

By T.R. Ramsland, Mar. 99.

WP- 141

Reindeer of the Russian Arctic.

By S.E. Belikov, A.N. Boltunov & T.P. Belikova, Mar. 99.

WP- 142

A Guide to EIA Implementation for the NSR.

By J. Thomassen, K.A. Moe, O.W. Brude, S.M. Chivilev, M. Gavrilov, V. Khlebovich, V. Pogrebov, G. Semanov, & S. Zubarev, Mar. 99.

WP- 143

Scenarios of Seasonal and Year-Round Navigation along the Northern Sea Route.

By Y.M. Ivanov, N.A. Isakov, A.N. Yakovlev, V. P. Smirnov, A.E. Nikulin & E.G. Logvinovich, Mar. 99.

WP- 144

Energy Prospects in Yamalo-Nenets Autonomous Okrug.

By T.R. Ramsland, Mar. 99.

WP- 145

Cargo Analysis, North West Europe - The Far East & Canada US West Coast - NW Europe.

By T.R. Ramsland, Mar. 99.

WP- 146

Financing the NSR: Regional Aspects.

By V. Kryukov, A. Moe & V. Shmat, Mar. 99.

WP- 147

Legal Regime of Navigation in the Russian Arctic.

By A. Kolodkin, O. Kulistikova, E. Mohova & I. Mihkina, Mar. 99.

WP- 148

Report on Residents of the Nenets AO, Past and Present Impacts of Development of the NSR.

By E.N. Andreeva, Mar. 99.

WP- 149

Impact of the Northern Sea Route and the Activity of the Lena River Steamship Line on the Socio-Economic Situation and Development of the Sakha Republic (Yakutia).

By V.I. Pavelenko & A.N. Yakovlev, Mar. 99.

WP- 150

A Time and Cost Prediction Model for Northern Sea Route Shipping.

By N.D. Mulherin, D.T. Eppler & D.S. Sodhi, Mar. 99.

WP- 151

Arctic Environmental Law. Harmonization of Polar Ship Rules. International and National Provisions.

By L.G. Tsoy, S.B. Karavanov, Yu.V. Glebko, M.A. Grechin & V.V. Mikhailichenko, Mar. 99.

WP- 152

The Northern Sea Route and Local Communities in Northwest Russia: Social Impact Assessment for the Murmansk Region.

By Y. Konstantinov, Mar. 99.

WP- 153

Environmental Policy in the Russian Arctic: Formation, Implementation, Effectiveness.

By V. Kotov & E. Nikitina, Mar. 99.

WP- 154

The Sami People and the Northern Sea Route: Juridical, Social and Cultural Concerns.

By L.-N. Lasko with G. Osherenko, Mar. 99.

WP- 155

Simulation of Ship Transit through Ice.

By K. Riska & M. Patey, Mar. 99.

WP- 156

The Russian Fertiliser Industry.

By T.R. Ramsland, Mar. 99.

WP- 157

The Angara - Yenisey Region.

By T.R. Ramsland, Mar. 99.

WP- 158

The Russian Far East Region.

By T.R. Ramsland, Mar. 99.

WP- 159

The Application of LOSC Article 234 - Russian Arctic Waters.

By R.D. Brubaker, Mar. 99.

WP- 160

Design Requirements for Future NSR Ships.

By L.G. Tsoy, S.B. Karavanov, Yu.V. Glebko, F.A. Moreinis, N.A. Vyssotskaya & S.M. Ponomarev, Mar. 99.

WP- 161

Modification of Canadian Ice Regime System to Include Ship Operation.

By R. Frederking, Mar. 99.

WP- 162

NSR Valued Ecosystem Components: Indigenous People, Wild Reindeer, Domestic Reindeer and Protected Areas.

By J. Thomassen, W. Dallmann, K. Isaksen, V. Khlebovich & Ø. Wiig, Mar. 99.

WP- 163

NSR Environmental Impact Statement.

By J. Thomassen, K.A. Moe & O.W. Brude, Mar. 99.

WP- 164

Simulation of NSR Navigation Based on Year Round and Seasonal Operation Scenarios.

By K. Kamesaki, S. Kishi & Y. Yamauchi, Mar. 99.

WP- 165

INSROP GIS v3.0a - User's Guide and System Documentation.

By S.M. Løvås, Mar. 99.

WP- 166

INSROP GIS - Data Set Documentation & Information Structure

By O.W. Brude, S.M. Lovas & C. Smith, Mar. 99.

WP- 167

INSROP Integration Book.

By W. Østreng (ed.) et al, Mar. 99.

Appendix F: Other INSROP Source Data

1. Charts of the NSR

CNIIMF, the Russian partner in INSROP, supplied 203 charts of the NSR (actual-size photocopies of the 1994 Russian-language edition), which are an enormously valuable source of data. This data consisted of charts of the Russian coast along the NSR, with the locations of the observation points provided on the pages following each chart.

The charts received from CNIIMF are now housed at Tokyo University of Mercantile Marine. A microfilm version resides with the SOF.

The Russian charts were revised for INSROP, and as of January 1, 1999 some 329 of these charts have been published. To obtain copies of the revised versions, please refer to the information below.

(1) Sales outlet

Navi-Dals Corp. (Director: O. V. Glushkova)

17, Chapayev Street, St. Petersburg, 197046 Russia

Tel/fax: (812) 233-4437

(2) Types of charts and prices

The following information is based on catalog no. 7107 and is correct as of January 1, 1998.

Positions of observation points

Item No.	Designation	Measuring Unit	Unit Price (US \$)
1	Sem chart (radio-facility chart, navigation and fishery chart, general purpose and review/geographical map with a clearly evident representation of the sea bottom relief, with bearing and distance grids, hydrometeorological chart) with corrections	1 sheet	13
2	Navigational chart (general navigation chart, gidroacoustic, chart of inland shipping routes, ocean grounds, for rescue facilities, time zone chart, for yachts and pleasure boats, sightseeing places) with corrections	1 sheet	12
3	Outline nautical chart (hydrometeorological chart range/ azimuth, submarine cable laying, maneuvering platters, demonstration plans, charts of distances, flooding areas)	1 sheet	3
4	Nautical lattice chart	1 sheet	1
5	Insert for the chart	1 copy	3
6	Sailing directions. Instructions for ships calling at a port (with corrections)	1 book	20
7	Lights and marks, Radio engineering navigation equipment. Yearbook of Nautical astronomy. Tide tables (with corrections)	1 book	14
8	Correction tables for radionavigation systems, nautical distances etc.	1 book	8
9	Catalogue, Sailing Regulations (with corrections)	1 book	20
10	Instructions and Reference books (Manuals) 1 group 2 group 3 group	1 book 1 book 1 book	16 9 4
11	Ocean atlas, hydrometeorological atlases 1 group 2 group 3 group	1 book 1 book 1 book	16 9 4
12	Summary corrections	1 book	1
13	Supplements	1 book	2
14	Blanks and forms	1 form	1

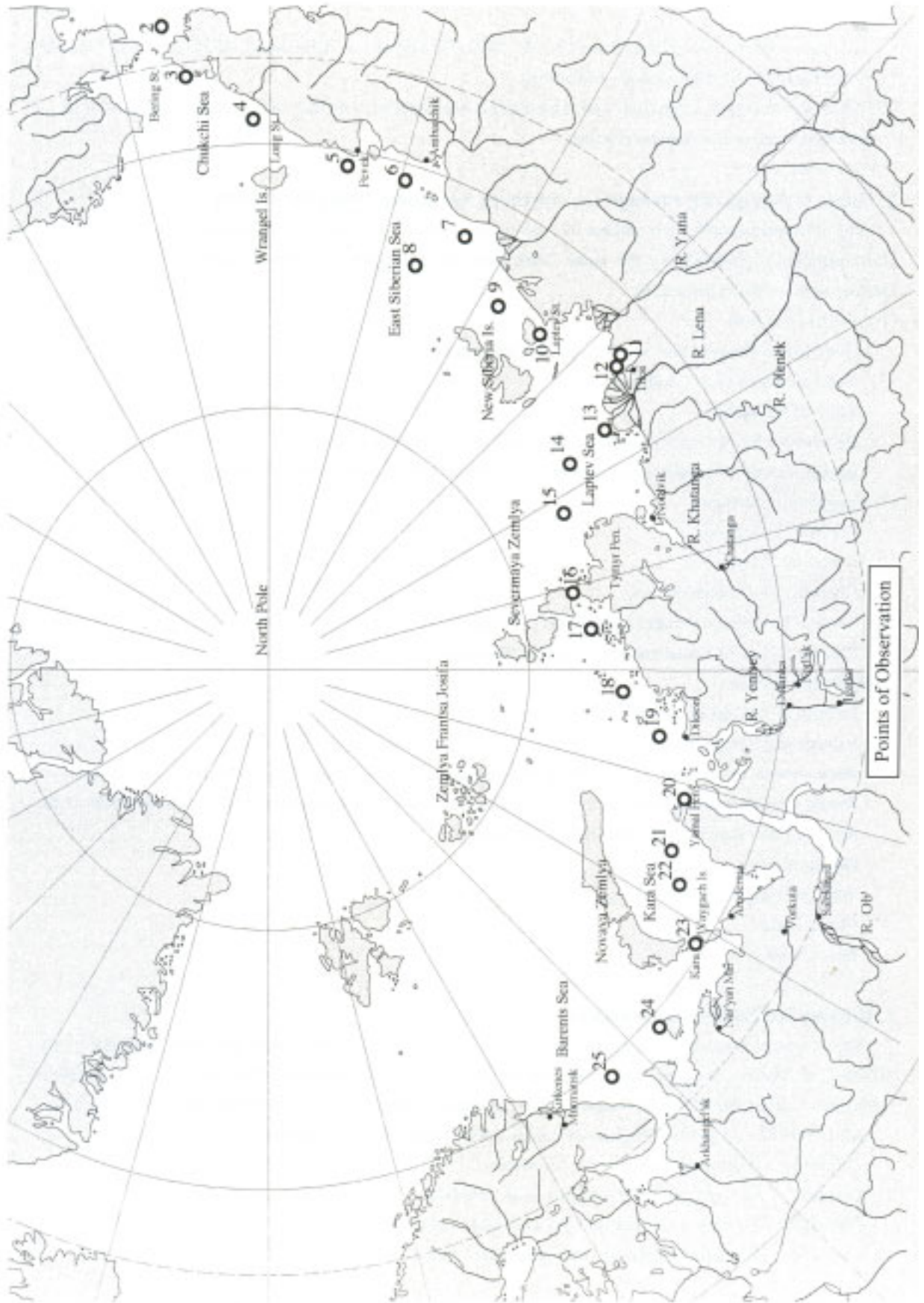

Appendix

Note:

Foreign customers are offered Price-List No.708-1 for editions of the Central Office of Navigation and Oceanography of the RF Ministry of Defense.

When the summary corrections and supplements are supplied with the sailing directions, their price is included in the sailing directions price.

2. Guide to Navigating through the Northern Sea Route 1996 (No. 4151B)

This document (publication number 29, 384 pages) is practically the English-language version of Russia's NSR regulations, published by the Head Department of Navigation and Oceanography of the Ministry of Defense of the Russian Federation.

(1) General Overview

- Overview of Geographical and Navigation Conditions
- Hydrometeorological Conditions
- Rules of Navigation
- Regulations for Navigation on the Seaways of the Northern Sea Route
- Regulations for Icebreaker and Pilot Guiding of Vessels through the Northern Sea Route

(2) Navigation Directions

- Chapter 1 : Kara Sea
- Chapter 2 : Laptev Sea
- Chapter 3 : East Siberian Sea
- Chapter 4 : Chukchi Sea and Approaches to Bering Strait
- Chapter 5 : List of Visual and Radio Aids to Navigation

(3) Reference Section

- Practice of Navigation in Ice
- Salvage and Rescue Support
- Requirements for the Design, Equipment and Supplies of Vessels Navigating the Northern Sea Route
- Rough Correspondence between the Literal Designations of Ice Resistance in the Class Symbols of the Russian Federation Registry and Other Classifying
- Organizations
- Table of Horizon Visibility Range
- Morse Code
- Illustrations

3. Russian Ice Navigation Practices

This 83-page manual was prepared by the Head Department of Navigation and Oceanography of the Ministry of Marine Shipping and published by the Ministry of Defense. The manual is an excellent compendium of the knowledge of Russian sailors, gained from many years of experience with NSR navigation.

Also available in Japanese, this manual consists of the following four chapters:

- Chapter 1 Unescorted navigation in icy waters
- Chapter 2 Navigation with the support of an icebreaker
- Chapter 3 Navigation of pack ice with icebreaker support
- Chapter 4 Navigation of fast ice with icebreaker support

4. Regulations for Navigation on the Seaways of the Northern Sea Route 1991

These regulations for NSR navigation were prepared on the basis of a Soviet Politburo Decree No. 565 (June 1,1990), taking into account both Soviet requirements and the dictates of international law. Approval was granted by the Soviet Ministry of Commercial Shipping on September 14, 1990.

Also available in Japanese, this document consists of the following 12 chapters:

- Chapter 1 Definitions
- Chapter 2 Grounds, Objectives and Scope of Regulations
- Chapter 3 Requests for Escort in the Northern Sea Route
- Chapter 4 Requirements for Ships and Piloting Responsibilities
- Chapter 5 Guarantee against Payment of Damages
- Chapter 6 Inspection
- Chapter 7 Navigation Regulations
- Chapter 8 Control of Shipping
- Chapter 9 Prohibition of Shipping
- Chapter 10 Removal of Ships that Stray Off-Course
- Chapter 11 Responsibilities
- Chapter 12 Notice (marine pollution)

5. Natural Resources of Russia along Eastern Half of the Northern Sea Route

The shipment of freight is a critical part of any plan to put the NSR to effective use, and particularly important is the shipment of natural resources within the NSR. Yet until now little has been published about this vital topic. The SOF therefore specially requested CNIIMF to gather the relevant data. This 35-page report, published in Russian, contains some of that data.

A 57-page Japanese translation is also available. Its content is as follows.

- (1) National science and technology programs (multidisciplinary oceanographic research at the North and South Poles)

Five volumes of research reports published 1991-1995 by the following agencies:

Federal Ministry of Science and Technology Policy, Russian Academy of Science, Russian Federal Ministry of Protection of the Environment and Natural Resources, Russian Federal Ministry of Fuel and Energy, Russian Federal Ministry of Transportation, Russian Federal Committee on Geology and Use of Mineral Resources, Russian Federal Meteorological and Environmental Monitoring Agency, Russian Academy of Medicine

- * Geological and economic evaluations of estimates of oil and natural gas reserves on the continental shelf of Russia's eastern Arctic
 - * Assessment of mineral resources
 - * Conclusions
 - * References
- (2) Essay in the August, 1993 edition of the journal Exploration and Protection of Mineral Resources (in Japanese)
- 1) Review of present state of geological knowledge in Russia and discovery of new mining areas
 - * Aldan Shield, Yenisey Shield, Anabar Shield
 - * Northern Russia
 - 2) Oil and gas resources on Russia's continental shelf
 - * Continental shelf of the Arctic Ocean

Appendix

* Far Eastern continental shelf

- (3) Essay in the June, 1997 edition of the journal The CIS Oil and Natural Gas Plant Market, "What investors are waiting for in eastern Siberia" (in Japanese)

6. Miscellaneous Source Data

Other related source data are as follows.

- (1) : (Atlas of the Oceans: The Arctic Ocean) 1980
(184p.)
- (2) Morphometric Characteristics of Ice and Snow in the Arctic Basin (152p.)
Romanov, I.P., 1993, St.Petersburg
- (3) Ice Cover of the Arctic Basin (192p.)
Romanov, I.P., 1994, St.Petersburg
- (4) Atlas of Ice and Snow of the Arctic Basin and Siberian Shelf Seas (277p.)
- (5) Atlas of Arctic Icebergs (70p.)
- (6) Northern Sea Route Directory of Icebreaking Ships,1994-1995,(217p.)
- (7) Transport Canada-Ship Safety Northern Region Reference Regulations (312p.)
- (8) 1995 (Photo Album of Sea Ice Formation)
(143p.)
- (9) 1994(Dictionary of Sea Ice Terminology) (104p.)
- (10) Arctic Pollution Issues:
A state of the Arctic Environment Report (188p.)
AMAP : Arctic Monitoring and Assessment Programme, Oslo 1997.
- (11) National Security and International Environmental Cooperation
In the Arctic - the Case of the Northern Sea Route (367p.)
Prof. Willy Ostreng, Oslo 1999.
- (12) Chukchi Sea
Oil & Gas Lease Sale 126, Final Environmental Impact Statement
Volume I, . 1991
MMS : U.S. Department of the Interior Minerals Management Service
Alaska OCS Region
- (13) IASC Project Catalogue 1998
The International Arctic Science Committee (44p.)

7. Web Sites for the Arctic and Antarctic Research Institute of Russia

Although properly this does not belong in a list of source data, one of the results of this project is the launch of a searchable website of the data possessed by AARI. The publication of the data in this form is of significant benefit to anyone interested in the NSR.

<http://www.aari.nw.ru>

Note: Due to limitations on the communication infrastructure in Russia, this site may be unavailable at certain times.

A part of AARI's Arctic ice data is published on this site.

A great deal of historical information is available, analysis of satellite data for navigational purposes. The historical information has been incorporated into INSROP GIS, and the analytical results are in the process of

being updated, so that the most recent information can be made available.

(1) Historical ice data

Historical data are displayed in the SIGRID format. Principally consisting of ice charts, these data can be searched and displayed as GIF images. The SIGRID data can also be downloaded.

The published AARI data includes the following.

* Annual and monthly ice charts

1) Ice charts for each August, 1953-1990

2) Ice charts for each January-December, 1992

* Statistical analyses

Ice charts based on monthly averages, maximums and minimums, 1953-1990

Ice charts based on data from the National Ice Center (NIC) are also published.

(2) Operation Data

Operation data are images of ice charts, provided up-to-the-minute before the images are digitalized.

* Ice maps produced weekly

* Forecasts of ice movement and tides/currents for the following six days

Notes on Contributors



Hiromitsu KITAGAWA

Born in Tokyo in 1935, Dr. Kitagawa accepted a post at the Ship Research Institute, Ministry of Transport soon after graduating from the Department of Naval Architecture at Yokohama National University. His career at the Institute included the posts of Head of Ship Performance Division and General-Director of the Institute. After a stint as President of the Shipbuilding Research Centre of Japan, he was appointed a professor at the Civil Engineering of Hokkaido University in Sapporo, chairing the Ice and Snow Technology Laboratory. His main areas of work include ship hydrodynamics, ice and snow engineering, marine environmental technology and railway engineering. Because of his breadth of interest and understanding in many areas critical to the project, as well as his extensive international career, Dr. Kitagawa served INSROP as its overall coordinator.



Nobuo ONO

Born in Tokyo in 1933, Prof. Ono started his career in cold-region research at the Institute of Low Temperature Science (ILTS), Hokkaido University, after graduating from the Faculty of Science, Tohoku University. Over his long career, Prof. Ono has taken part in numerous scientific expeditions, such as the Japanese Antarctic Research Expedition in 1958-59(IGY) and the Arctic Ice Dynamics Joint Experiment (AIDJEX) in 1972. His professional career includes the posts of professor at the Institute of Low Temperature Science, Head of the Arctic Environment Research Center, Deputy Director of the National Institute of Polar Research (NIPR) and Dean of the School of Mathematical and Physical Science at the Graduate University for Advanced Studies (GUAS). Prof. Ono has been a member of the International Arctic Science Committee and Arctic Ocean Science Board. After retiring from the NIPR and GUAS, he became a Professor Emeritus of both NIPR and GUAS. Today Prof. Ono serves as President of the Japanese Society of Snow and Ice.



Hajime YAMAGUCHI

Prof. Yamaguchi was born in Mie prefecture in 1955. He received his PhD from the Department of Naval Architecture and Ocean Engineering, University of Tokyo. Immediately after graduation, Prof. Yamaguchi joined the teaching staff at the same department. He is currently a professor at the Department of Environmental and Ocean Engineering, University of Tokyo. His work on polar environmental engineering includes numerical prediction of pack ice flow and fluid engineering, including cavitation. During 1992-1993 he was a guest researcher at the Institute for Marine Dynamics, National Research Council of Canada. Prof. Yamaguchi has received several awards from such bodies as the Society of Naval Architects of Japan, the Ocean Offshore and Arctic Engineering Division of the American Society of Mechanical Engineers and the Visualization Society of Japan. In INSROP, Prof. Yamaguchi executed a study on ice condition prediction systems and was the leader of the expedition team of the experimental voyage along the Northern Sea Route.



Koh IZUMIYAMA

Koh Izumiyama was born in 1957 in Sapporo, Hokkaido. In 1983, after graduating from Hokkaido University, he entered the Ship Research Institute, Ministry of Transport. He has been working on ice-related subjects such as ice-going ships, ice loading on offshore structures and model testing in ice. He joined the 26th Japan Antarctic Research Expedition and worked at the National Research Council of Canada as a visiting researcher for a one-year term. In INSROP he took part in the experimental voyage in the Northern Sea Route in 1995.



Kazuhiko KAMESAKI

Born in 1951 in Fukuoka prefecture, Kazuhiko Kamesaki graduated from the master course of naval architecture at Kyushu University and earned a Ph.D. at Hokkaido University. He has worked with NKK Corporation since 1976, specializing in ice engineering topics for over 20 years. He is presently Head of Ship and Marine Engineering Laboratory at Tsu, Japan.

Dr.Kamesaki was engaged in INSROP 1993-1998 as a reviewer, supervisor and coordinator of the NSR simulation study and co-author of the Integration Book. Dr. Kamesaki took part in the experimental voyage in the Northern Sea Route in 1995, along with Prof. Yamaguchi and Mr. Izumiyama.